

## **WSDOT Errata to FOP for AASHTO T 355**

### ***In-Place Density of Asphalt Mixtures by Nuclear Methods***

WAQTC FOP for AASHTO T 355 has been adopted by WSDOT with the following changes:

#### **Material**

Filler material: *Not used by WSDOT, unless SMA is being placed, then use filler material as described.*

#### **Test Site Location**

*Replace step 1 with below:*

1. WSDOT requires test location selected per WSDOT Test Method 716.

#### **Procedure**

**Method A – Average of two one-minute tests** - *Not recognized by WSDOT use Method B:*

### **APPENDIX – CORRELATION WITH CORES**

#### **Correlation with Cores**

*Replace step 2 with below:*

1. Obtain a pavement core from each of the test sites according to WSDOT SOP 734. The core should be taken from the center of the nuclear gauge footprint.



## **IN-PLACE DENSITY OF ASPHALT MIXTURES BY NUCLEAR METHODS FOP FOR AASHTO T 355**

### **Scope**

This test method describes a procedure for determining the density of asphalt mixtures by means of a nuclear gauge using the backscatter method in accordance with AASHTO T 355-18. Correlation with densities determined under the FOP for AASHTO T 166 is required by some agencies.

### **Apparatus**

- Nuclear density gauge with the factory-matched standard reference block.
- Transport case for properly shipping and housing the gauge and tools.
- Instruction manual for the specific make and model of gauge.
- Radioactive materials information and calibration packet containing:
  - Daily standard count log
  - Factory and laboratory calibration data sheet
  - Leak test certificate
  - Shippers' declaration for dangerous goods
  - Procedure memo for storing, transporting, and handling nuclear testing equipment
  - Other radioactive materials documentation as required by local regulatory requirements

### **Material**

- Filler material: Fine-graded sand from the source used to produce the asphalt pavement or other agency approved materials.

### **Radiation Safety**

This method does not purport to address all of the safety problems associated with its use. This test method involves potentially hazardous materials. The gauge utilizes radioactive materials that may be hazardous to the health of the user unless proper precautions are taken. Users of this gauge must become familiar with the applicable safety procedures and governmental regulations. All operators will be trained in radiation safety before operating nuclear density gauges. Some agencies require the use of personal monitoring devices such as a thermoluminescent dosimeter or film badge. Effective instructions, together with routine safety procedures such as source leak tests, recording and evaluation of personal monitoring device data, etc., are a recommended part of the operation and storage of this gauge.

## Calibration

Calibrate the nuclear gauge as required by the agency. This calibration may be performed by the agency using the manufacturer's recommended procedures or by other facilities approved by the agency. Verify or re-establish calibration curves, tables, or equivalent coefficients every 12 months.

## Standardization

1. Turn the gauge on and allow it to stabilize (approximately 10 to 20 minutes) before standardization. Leave the power on during the day's testing.
2. Standardize the nuclear gauge at the construction site at the start of each day's work and as often as deemed necessary by the operator or agency. Daily variations in standard count shall not exceed the daily variations established by the manufacturer of the gauge. If the daily variations are exceeded after repeating the standardization procedure, the gauge should be repaired, recalibrated, or both.
3. Record the standard count for both density and moisture in the daily standard count log. The exact procedure for standard count is listed in the manufacturer's Operator's Manual.

*Note 1:* New standard counts may be necessary more than once a day. See agency requirements.

## Test Site Location

1. Select a test location(s) randomly and in accordance with agency requirements. Test sites should be relatively smooth and flat and meet the following conditions:
  - a. At least 10 m (30 ft.) away from other sources of radioactivity.
  - b. At least 3 m (10 ft.) away from large objects.
  - c. If the gauge will be closer than 600 mm (24 in.) to any vertical mass, or less than 300 mm (12 in.) from a vertical pavement edge, use the gauge manufacturer's correction procedure.

## Procedure

1. Maintain maximum contact between the base of the gauge and the surface of the material under test.
2. Use filler material to fill surface voids.
3. Spread a small amount of filler material over the test site surface and distribute it evenly. Strike off the surface with a straightedge (such as a lathe or flat-bar steel) to remove excess material.
4. If using thin-layer mode, enter the anticipated overlay thickness into the gauge.

*Note 2:* If core correlation is required, entered thickness, anticipated thickness, and nominal core thickness may be required to match.

**Method A – Average of two one-minute tests**

1. Place the gauge on the test site, perpendicular to the roller passes.
2. Using a crayon (not spray paint), mark the outline or footprint of the gauge.
3. Extend the source rod to the backscatter position.
4. Take a one-minute test and record the wet density reading.
5. Rotate the gauge 90 degrees centered over the original footprint. Mark the outline or footprint of the gauge.
6. Take another one-minute test and record the wet density reading.
7. If the difference between the two one-minute tests is greater than  $40 \text{ kg/m}^3$  ( $2.5 \text{ lb/ft}^3$ ), retest in both directions. If the difference of the retests is still greater than  $40 \text{ kg/m}^3$  ( $2.5 \text{ lb/ft}^3$ ) test at 180 and 270 degrees.
8. The density reported for each test site shall be the average of the two individual one-minute wet density readings.

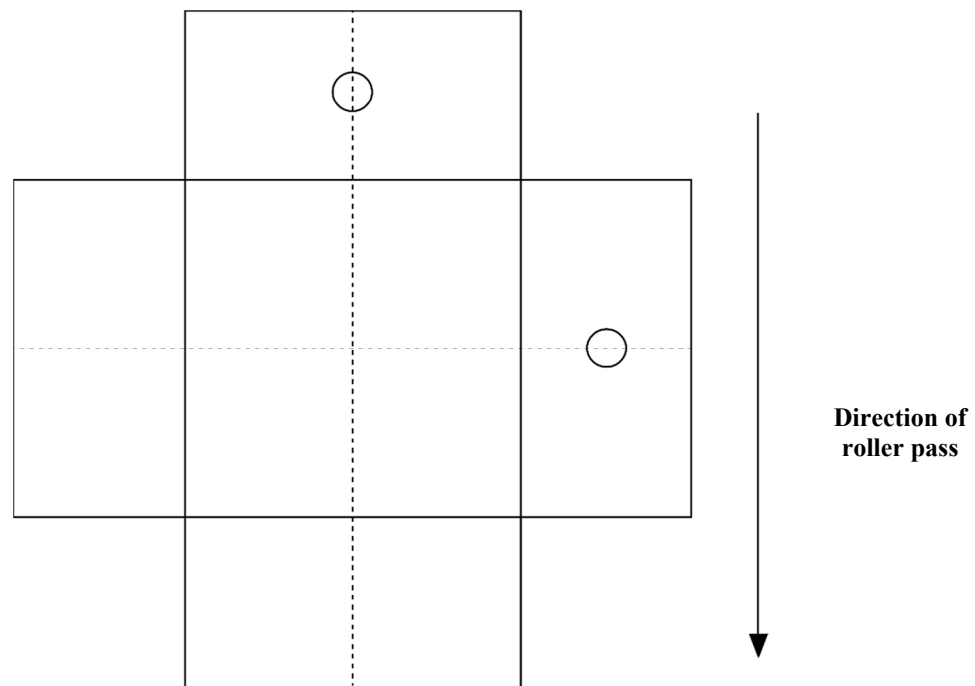
**Method A****Footprint of the gauge test site**

**Method B – One four-minute test**

1. Place the gauge on the test site, parallel to the roller passes.
2. Using a crayon (not spray paint), mark the outline or footprint of the gauge.
3. Extend the source rod to the backscatter position.
4. Take one 4-minute test and record the wet density reading.

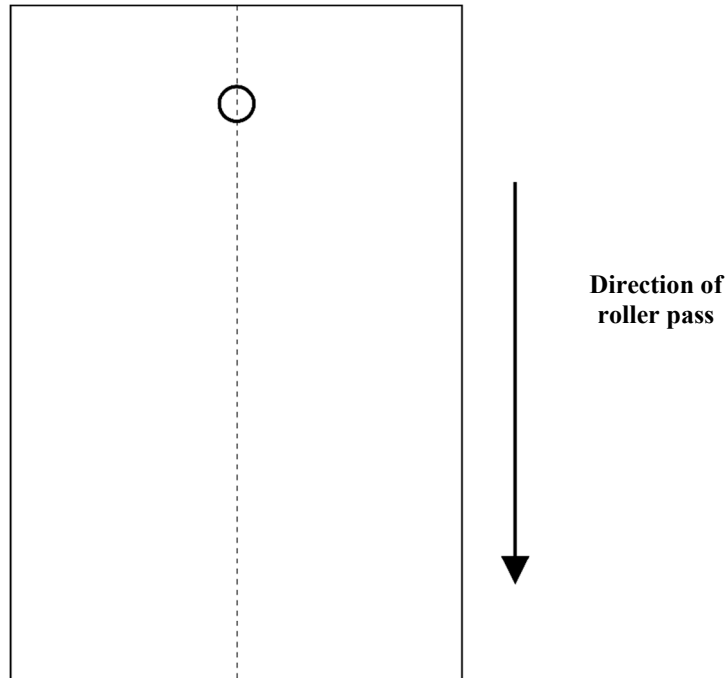

**Method B**  
**Footprint of the gauge test site**

IN-PLACE DENSITY

WAQTC

FOP AASHTO T 355 (20)

**Calculation of Results**

Percent (%) compaction is determined by comparing the in-place wet density as determined by this method to the appropriate agency density standard. See appropriate agency policy for use of density standards.

$$\% \text{ Compaction} = \frac{\text{Corrected Reading}}{\text{Maximum Density}} \times 100$$

**Method A Example:**Reading #1: 141.5 lb/ft<sup>3</sup>Reading #2: 140.1 lb/ft<sup>3</sup> Are the two readings within the tolerance? (YES)Reading average: 140.8 lb/ft<sup>3</sup>Core correction: +2.1 lb/ft<sup>3</sup>Corrected reading: 142.9 lb/ft<sup>3</sup>**Method B Example:**Reading: 140.8 lb/ft<sup>3</sup>Core correction: +2.1 lb/ft<sup>3</sup>Corrected reading 142.9 lb/ft<sup>3</sup>**Example percent (%) compaction:**

From the FOP for AASHTO T 209:

$$G_{mm} = 2.466$$

$$\text{Theoretical Maximum Density} = 2.466 \times 62.245 \text{ lb/ft}^3 = 153.5 \text{ lb/ft}^3$$

$$\% \text{ Compaction} = \frac{142.9 \text{ lb/ft}^3}{153.5 \text{ lb/ft}^3} \times 100 = 93.1\%$$

**Report**

- On forms approved by the agency
- Test ID
- Location of test and thickness of layer tested
- Mixture type
- Make, model and serial number of the nuclear moisture-density gauge
- Calculated wet density of each measurement and any adjustment data
- Density standard
- Compaction to the nearest 0.1 percent
- Name and signature of operator



## APPENDIX – CORRELATION WITH CORES

(Nonmandatory Information)

The bulk specific gravity ( $G_{mb}$ ) of the core is a physical measurement of the in-place asphalt mixture and can be compared with the nuclear density gauge readings. Comparing the core value to the corresponding gauge values, a correlation can be established.

The correlation can then be used to adjust the gauge readings to the in-place density of the cores. The core correlation is gauge specific and must be determined without traffic allowed on the pavement between nuclear density gauge readings and obtaining the core. When using multiple nuclear density gauges each gauge should be correlated to the core locations before removal of the core.

When density correlation with the FOP for AASHTO T 166 is required, correlation of the nuclear gauge with pavement cores shall be made on the first day's paving (within 24 hours) or from a test strip constructed before the start of paving. Cores must be taken before traffic is allowed on the pavement.

### Correlation with Cores

1. Determine the number of cores required for correlation from the agency's specifications. Cores shall be located on the first day's paving or on the test strip. Locate the test sites in accordance with the agency's specifications. Follow the "Procedure" section above to establish test sites and obtain densities using the nuclear gauge.
2. Obtain a pavement core from each of the test sites according to AASHTO R 67. The core should be taken from the center of the nuclear gauge footprint.

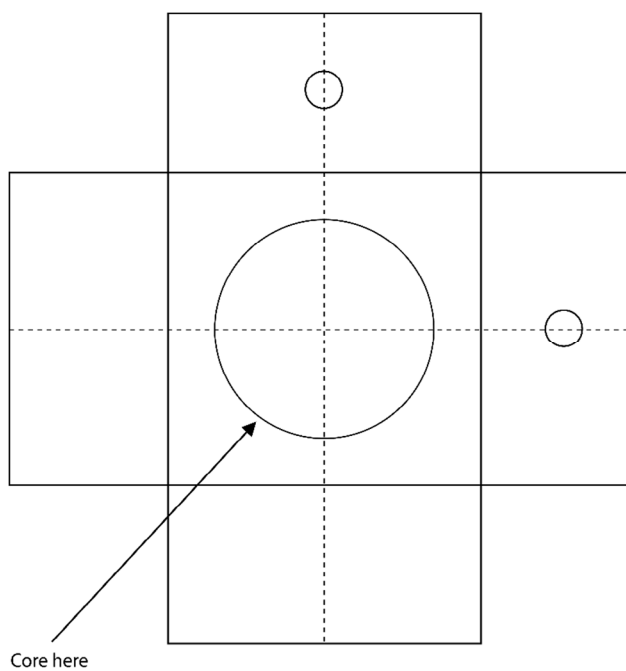

**Method A – Footprint of the gauge test site. Core location in the center of the footprint.**

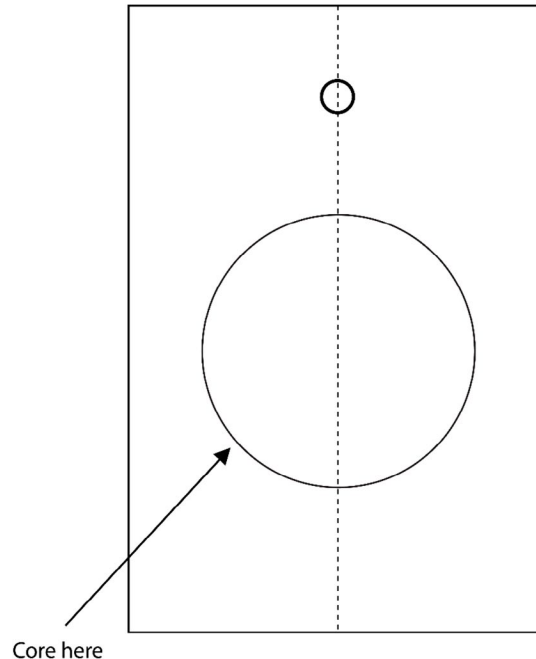

**Method B - Footprint of the gauge test site.**

3. Determine the density of the cores by the FOP for AASHTO T 166, Bulk Specific Gravity of Compacted Asphalt Mixtures Using Saturated Surface Dry Specimens.
4. Calculate a correlation factor for the nuclear gauge reading as follows:
  - a. Calculate the difference between the core density and the average nuclear gauge density at each test site to the nearest  $1 \text{ kg/m}^3$  ( $0.1 \text{ lb/ft}^3$ ). Calculate the average difference and standard deviation of the differences for the entire data set to the nearest  $1 \text{ kg/m}^3$  ( $0.1 \text{ lb/ft}^3$ ).
  - b. If the standard deviation of the differences is equal to or less than  $40 \text{ kg/m}^3$  ( $2.5 \text{ lb/ft}^3$ ), the correlation factor applied to the average nuclear gauge density shall be the average difference calculated above in 4.a.
  - c. If the standard deviation of the differences is greater than  $40 \text{ kg/m}^3$  ( $2.5 \text{ lb/ft}^3$ ), the test site with the greatest variation from the average difference shall be eliminated from the data set and the data set properties and correlation factor recalculated following 4.a and 4.b.
  - d. If the standard deviation of the modified data set still exceeds the maximum specified in 4.b, additional test sites will be eliminated from the data set and the data set properties and correlation factor recalculated following 4.a and 4.b. If the data set consists of less than five test sites, additional test sites shall be established.

**Note A1:** The exact method used in calculating the nuclear gauge correlation factor shall be defined by agency policy.

**Note A2:** The above correlation procedure must be repeated if there is a new job mix formula. Adjustments to the job mix formula beyond tolerances established in the contract documents will constitute a new

job mix formula. A correlation factor established using this procedure is only valid for the particular gauge used in the correlation procedure. If another gauge is brought onto the project, it shall be correlated using the same procedure. Multiple gauges may be correlated from the same series of cores if done at the same time.

**Note A3:** For the purpose of this procedure, a job mix formula is defined as the percent and grade of paving asphalt used with a specified gradation of aggregate from a designated aggregate source. A new job mix formula may be required whenever compaction of the wearing surface exceeds the agency's specified maximum density or minimum air voids.

## Calculations

### Correlation Factor

$$\sqrt{\frac{\sum x^2}{n-1}}$$

Where:

$\Sigma$  = Sum

x = Difference from the average Difference

n-1 = number of data sets minus 1

### Example

Core #	Core results from T 166:	Average Gauge reading	Difference:	x	x <sup>2</sup>
1	144.9 lb/ft <sup>3</sup>	142.1 lb/ft <sup>3</sup>	2.8 lb/ft <sup>3</sup>	-0.7	0.49
2	142.8 lb/ft <sup>3</sup>	140.9 lb/ft <sup>3</sup>	1.9 lb/ft <sup>3</sup>	0.2	0.04
3	143.1 lb/ft <sup>3</sup>	140.7 lb/ft <sup>3</sup>	2.4 lb/ft <sup>3</sup>	-0.3	0.09
4	140.7 lb/ft <sup>3</sup>	138.9 lb/ft <sup>3</sup>	1.8 lb/ft <sup>3</sup>	0.3	0.09
5	145.1 lb/ft <sup>3</sup>	143.6 lb/ft <sup>3</sup>	1.5 lb/ft <sup>3</sup>	0.6	0.36
6	144.2 lb/ft <sup>3</sup>	142.4 lb/ft <sup>3</sup>	1.8 lb/ft <sup>3</sup>	0.3	0.09
7	143.8 lb/ft <sup>3</sup>	141.3 lb/ft <sup>3</sup>	2.5 lb/ft <sup>3</sup>	-0.4	0.16
8	142.8 lb/ft <sup>3</sup>	139.8 lb/ft <sup>3</sup>	3.0 lb/ft <sup>3</sup>	0.9	0.81
9	144.8 lb/ft <sup>3</sup>	143.3 lb/ft <sup>3</sup>	1.5 lb/ft <sup>3</sup>	-0.6	0.36
10	143.0 lb/ft <sup>3</sup>	141.0 lb/ft <sup>3</sup>	2.0 lb/ft <sup>3</sup>	-0.1	<u>0.01</u>
Average Difference:			+2.1 lb/ft <sup>3</sup>	$\Sigma x^2 = 2.5$	

IN-PLACE DENSITY

WAQTC

FOP AASHTO T 355 (20)

**Number of data sets**

$$n - 1 = 10 - 1 = 9$$

**Standard deviation**

$$\text{standard deviation} = \sqrt{\frac{2.5}{9}} = 0.53$$

Given:

$$\text{Sum of } x^2 = 2.5$$

$$\text{Number of data sets} = 9$$

The standard deviation of 0.53 is less than 2.5 therefore no cores are eliminated. The average difference from all ten cores is used.

**PERFORMANCE EXAM CHECKLIST**

**IN-PLACE DENSITY OF ASPHALT MIXTURES BY NUCLEAR METHODS  
FOP FOR AASHTO T 355**

Participant Name \_\_\_\_\_ Exam Date \_\_\_\_\_

Record the symbols “P” for passing or “F” for failing on each step of the checklist.

Procedure Element	Trial 1	Trial 2
1. Gauge turned on approximately 10 to 20 minutes before use?	_____	_____
2. Gauge calibrated, and standard count recorded?	_____	_____
3. Test location selected appropriately [600 mm (24 in.) from vertical projections or 10 m (30 ft.) from any other radioactive sources]?	_____	_____
4. Filler spread evenly over test site?	_____	_____
5. Excess filler material removed by striking off the surface?	_____	_____
6. Gauge placed on pavement surface and footprint of gauge marked?	_____	_____
7. Source rod extended to backscatter position?	_____	_____
8. Method A:		
a. One-minute count taken; gauge rotated 90°, reseated, and another one-minute count taken?	_____	_____
b. Densities averaged?	_____	_____
c. If difference of the wet densities is greater than 40 kg/m <sup>3</sup> (2.5 lb/ft <sup>3</sup> ), retest conducted in both directions?	_____	_____
9. Method B:		
a. One four-minute count taken?	_____	_____
10. Core correlation applied if required?	_____	_____
11. Percent compaction calculated correctly?	_____	_____

Comments:      First attempt:    Pass \_\_\_\_\_ Fail \_\_\_\_\_      Second attempt: Pass \_\_\_\_\_ Fail \_\_\_\_\_

\_\_\_\_\_

\_\_\_\_\_

\_\_\_\_\_

Examiner Signature \_\_\_\_\_ WAQTC #: \_\_\_\_\_

IN-PLACE DENSITY

WAQTC

FOP AASHTO T 355 (20)