

PLAN VIEW

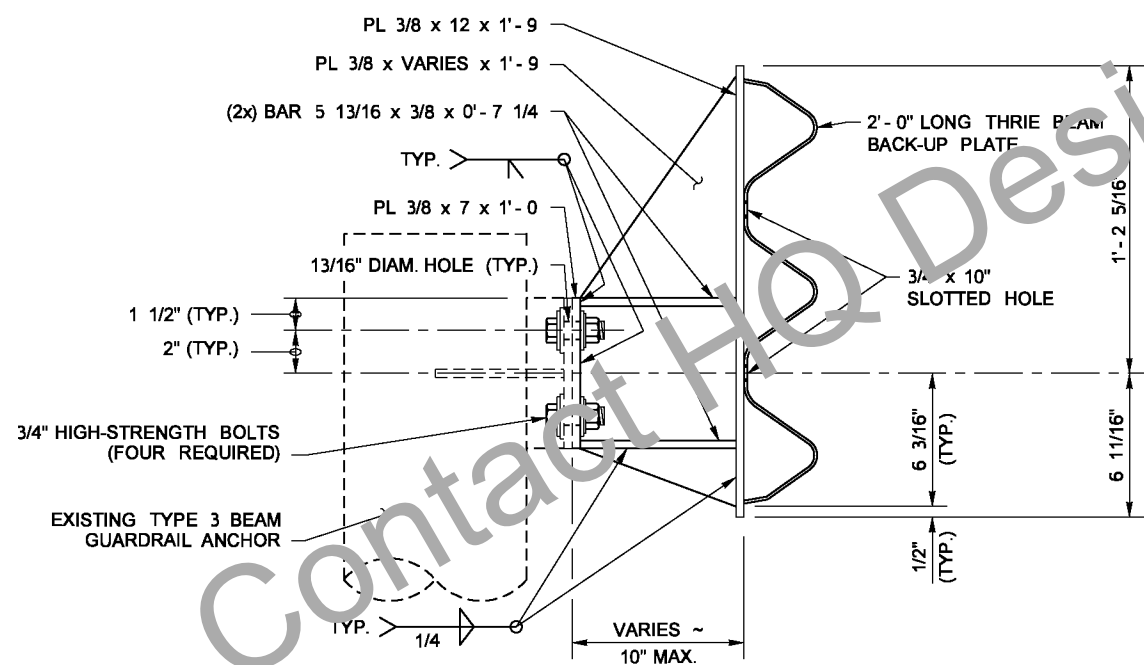

SECTION A

TYPE 3 GUARDRAIL ANCHOR
RETROFIT FOR THRIE BEAM
(DESIGN A)

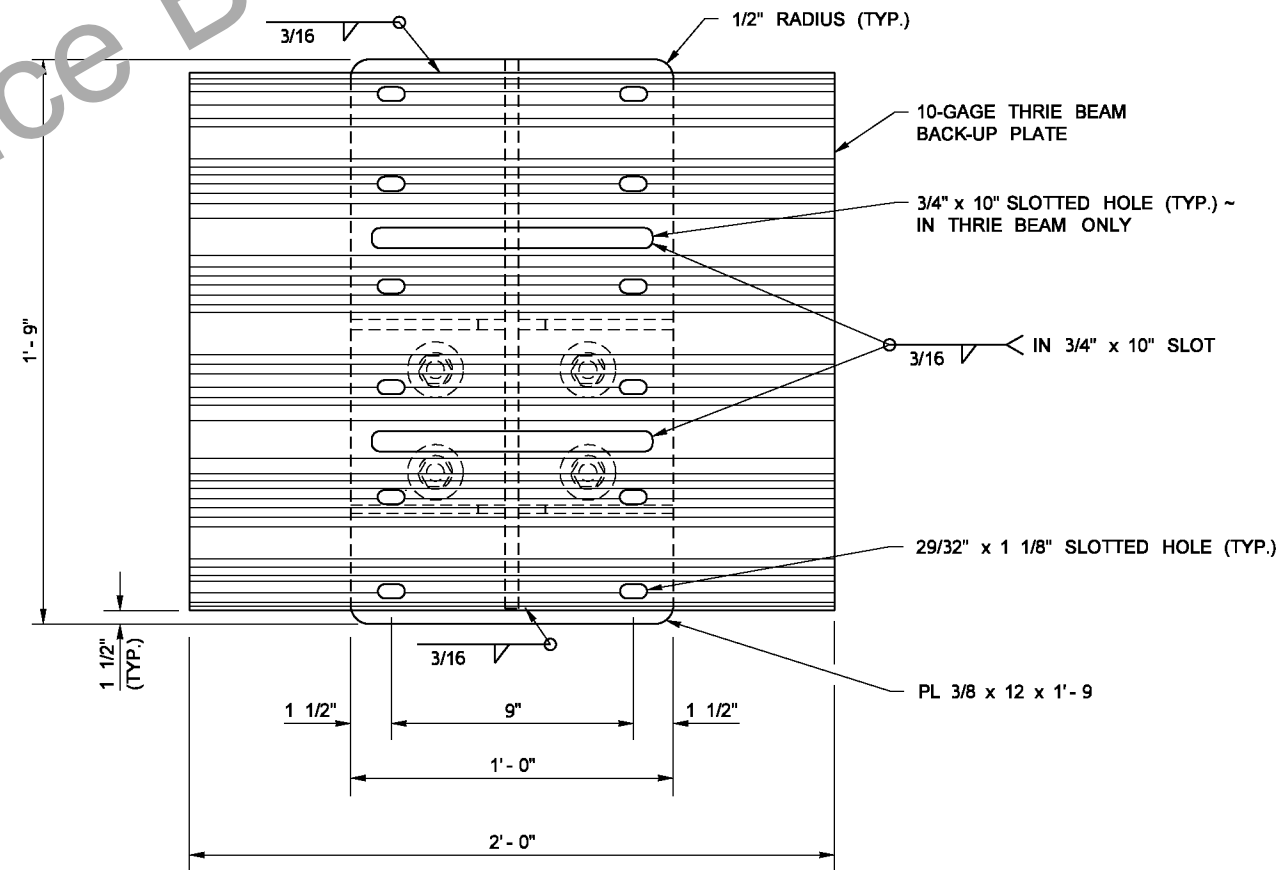

SECTION B

NOTES

- MATERIAL SPECIFICATIONS:
STEEL SHAPES & PLATES ASTM A 36 OR ASTM A 992
BOLTS, NUTS & WASHERS SECTION 9-16.8(1)
UNLESS OTHERWISE NOTED
- ALL STEEL POSTS AND PLATES SHALL BE GALVANIZED IN ACCORDANCE WITH AASHTO M 111 AFTER FABRICATION. BOLTS AND HARDWARE SHALL BE GALVANIZED IN ACCORDANCE WITH AASHTO M 232.
- ALL BOLT HOLES SHALL BE 1/16" LARGER THAN THE BOLT DIAMETER UNLESS OTHERWISE SPECIFIED. BOLT LENGTHS NOT SHOWN SHALL BE SIZED TO PROVIDE A 1/4" MIN. OF THREAD EXPOSED BEYOND THE NUT.
- DIMENSIONS SHALL BE MEASURED IN THE FIELD BY THE CONTRACTOR PRIOR TO FABRICATION OF ANY COMPONENTS.

| | | | |
|---------------|--|------|----|
| FILE NAME | S:\Design R P& S4-Standards\2-Plan Sheet Library\02-PSL Work in Progress\Bill\TB-50) Type 3 Guardrail Anchor Retrofit for Thrie Beam\TB-50.dgn | | |
| TIME | 4:20:16 PM | | |
| DATE | 3/3/2016 | | |
| PLOTTED BY | berensb | | |
| DESIGNED BY | | | |
| ENTERED BY | | | |
| CHECKED BY | | | |
| PROJ. ENGR. | | | |
| REGIONAL ADM. | REVISION | DATE | BY |

| | | |
|--------------|--------------|------------------|
| REGION NO. | STATE | FED.AID PROJ.NO. |
| 10 | WASH | |
| JOB NUMBER | | |
| CONTRACT NO. | LOCATION NO. | |

| | | | |
|----------------|------|----------------|------|
| P.E. STAMP BOX | DATE | P.E. STAMP BOX | DATE |
|----------------|------|----------------|------|



| |
|-------------|
| Plot 1 |
| PLAN REF NO |
| TB-50 |
| SHEET |
| OF |
| SHEETS |

**TYPE 3 GUARDRAIL RETROFIT
FOR THRIE BEAM**

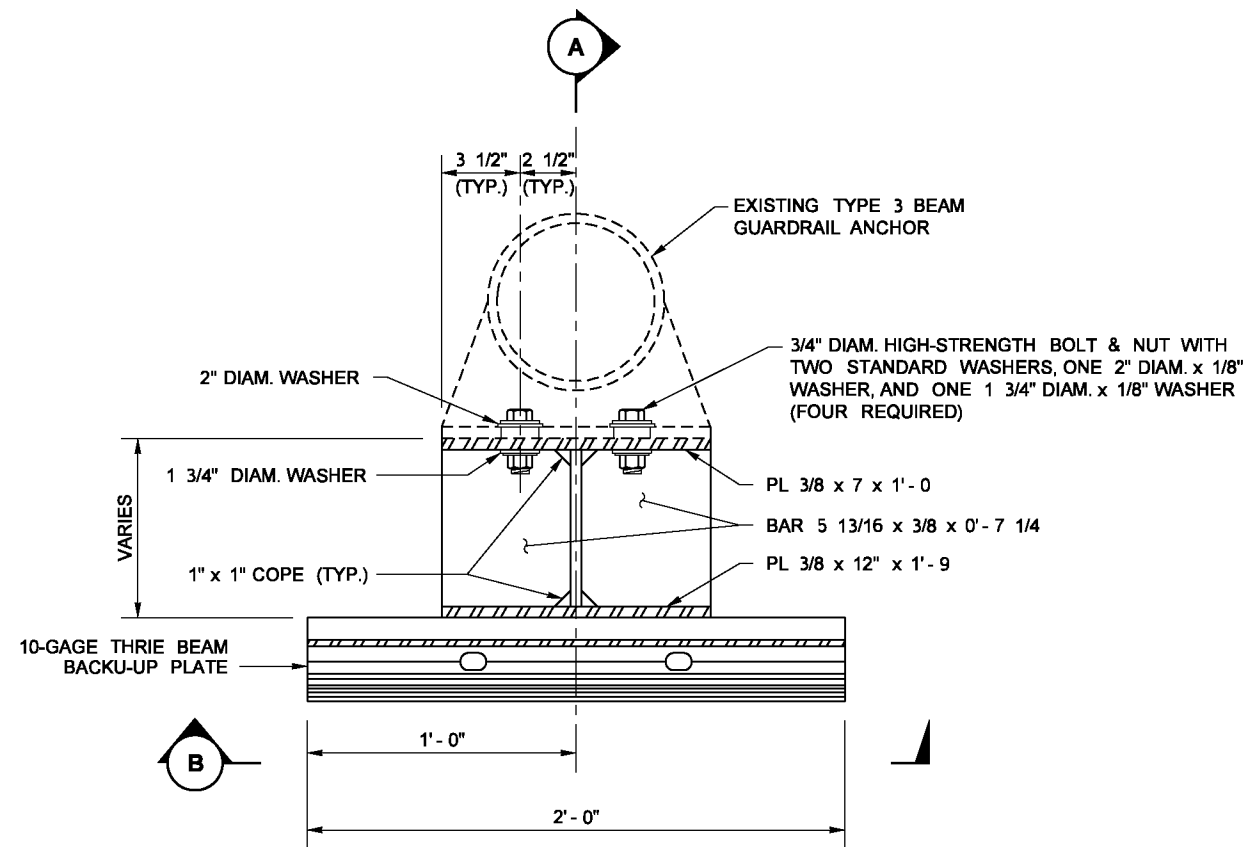

PLAN VIEW

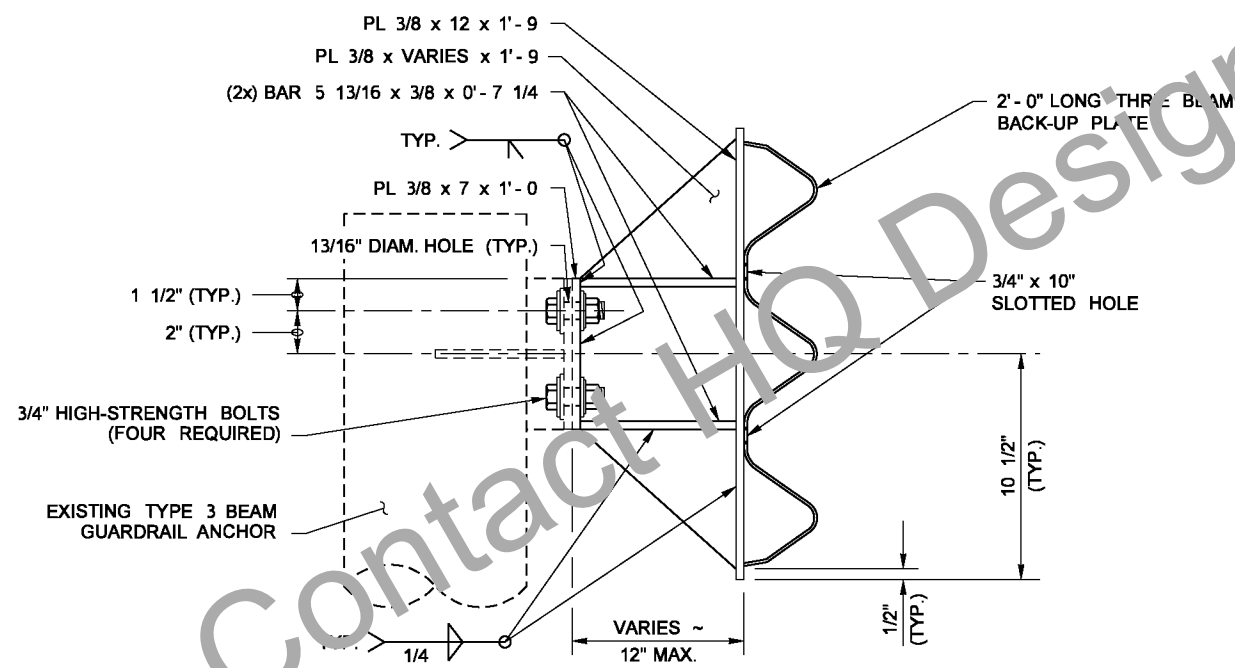

SECTION A

**TYPE 3 GUARDRAIL ANCHOR
RETROFIT FOR THRIE BEAM
(DESIGN B)**

NOTES

- MATERIAL SPECIFICATIONS:**
 STEEL SHAPES & PLATES ASTM A 36 OR ASTM A 992
 BOLTS, NUTS & WASHERS SECTION 9-16.8(1)
- ALL STEEL POSTS AND PLATES SHALL BE GALVANIZED IN ACCORDANCE WITH AASHTO M 111 AFTER FABRICATION. BOLTS AND HARDWARE SHALL BE GALVANIZED IN ACCORDANCE WITH AASHTO M 232.
- ALL BOLT HOLES SHALL BE 1/16\"/>
- DIMENSIONS SHALL BE MEASURED IN THE FIELD BY THE CONTRACTOR PRIOR TO FABRICATION OF ANY COMPONENTS.

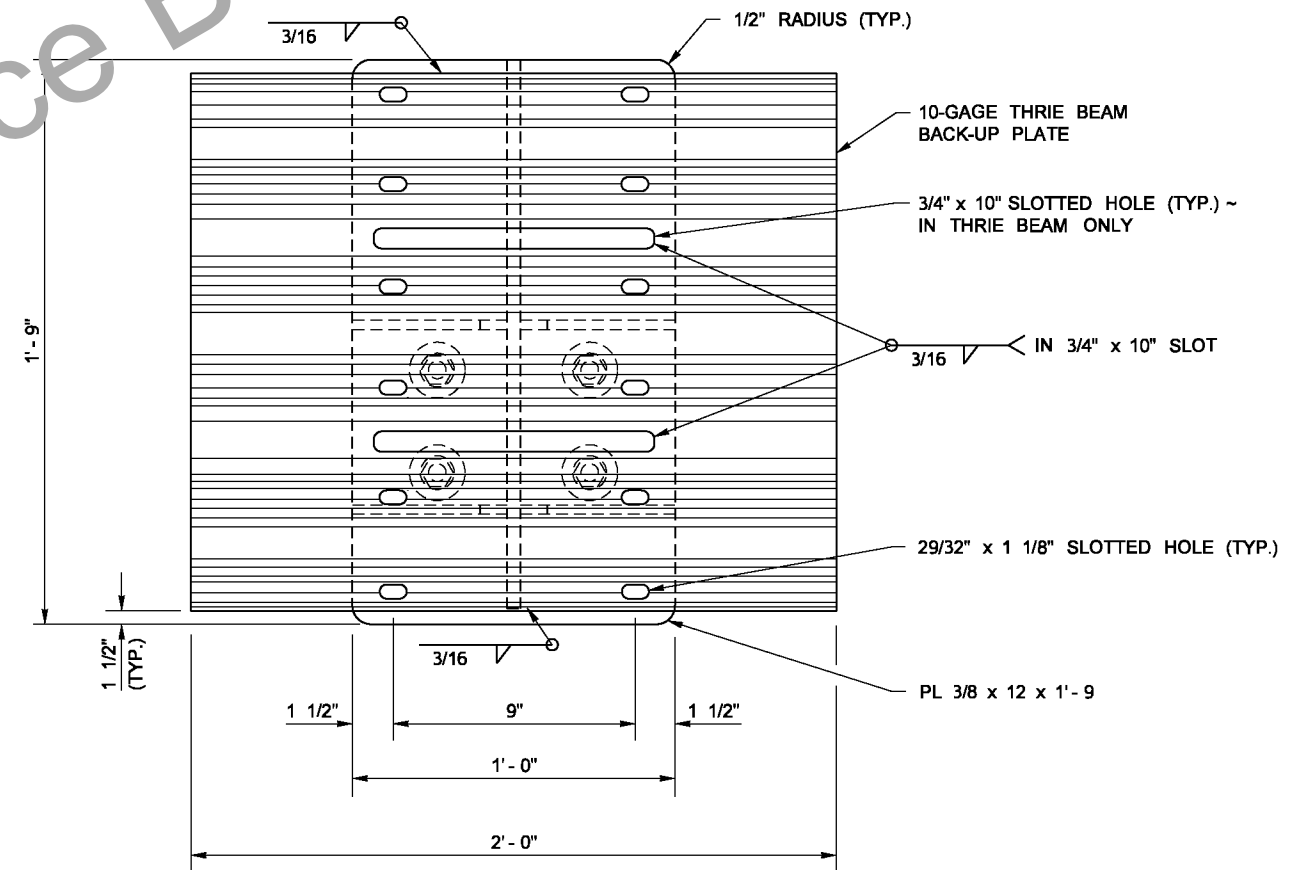

SECTION B

| | | | | | | | | | | | |
|--|--|------------------|--|------------------|--|----------------|--|----------------|--|-------------|--|
| FILE NAME S:\Design R P& S4-Standards\2-Plan Sheet Library\02-PSL Work in Progress\Bill\TB-50) Type 3 Guardrail Anchor Retrofit for Thrie Beam\TB-50.dgn | | REGION NO. STATE | | FED.AID PROJ.NO. | | DATE | | DATE | | Plot 2 | |
| TIME 4:20:53 PM | | 10 WASH | | | | P.E. STAMP BOX | | P.E. STAMP BOX | | PLAN REF NO | |
| DATE 3/3/2016 | | | | | | | | | | TB-50 | |
| PLOTTED BY berensb | | JOB NUMBER | | LOCATION NO. | | | | | | SHEET | |
| DESIGNED BY | | CONTRACT NO. | | | | | | | | 2 | |
| ENTERED BY | | | | | | | | | | OF | |
| CHECKED BY | | | | | | | | | | 2 | |
| PROJ. ENGR. | | | | | | | | | | SHEETS | |
| REGIONAL ADM. | | REVISION | | DATE | | BY | | | | | |

