

NOTE

1. SECURE THE CABINET TO THE PALLET WITH THE DETAILED BOLT ASSEMBLY IN EACH CORNER. HARDWARE SIZES PER MANUFACTURER'S RECOMMENDATIONS. TIGHTEN ASSEMBLY SNUG TIGHT.

DIMENSION TABLE		
HOUSING	X	Y
332/334	29"	40"
332D	40"	52"
P44	40"	52"
333SD	40"	52"

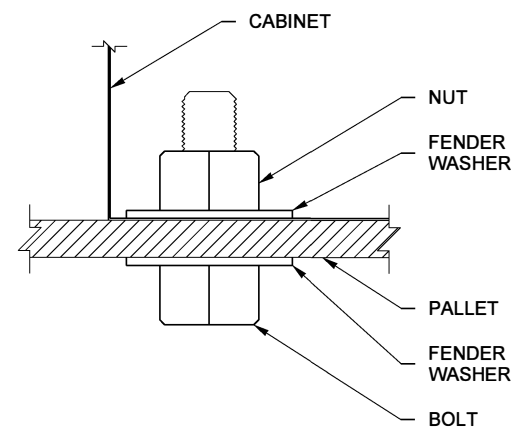
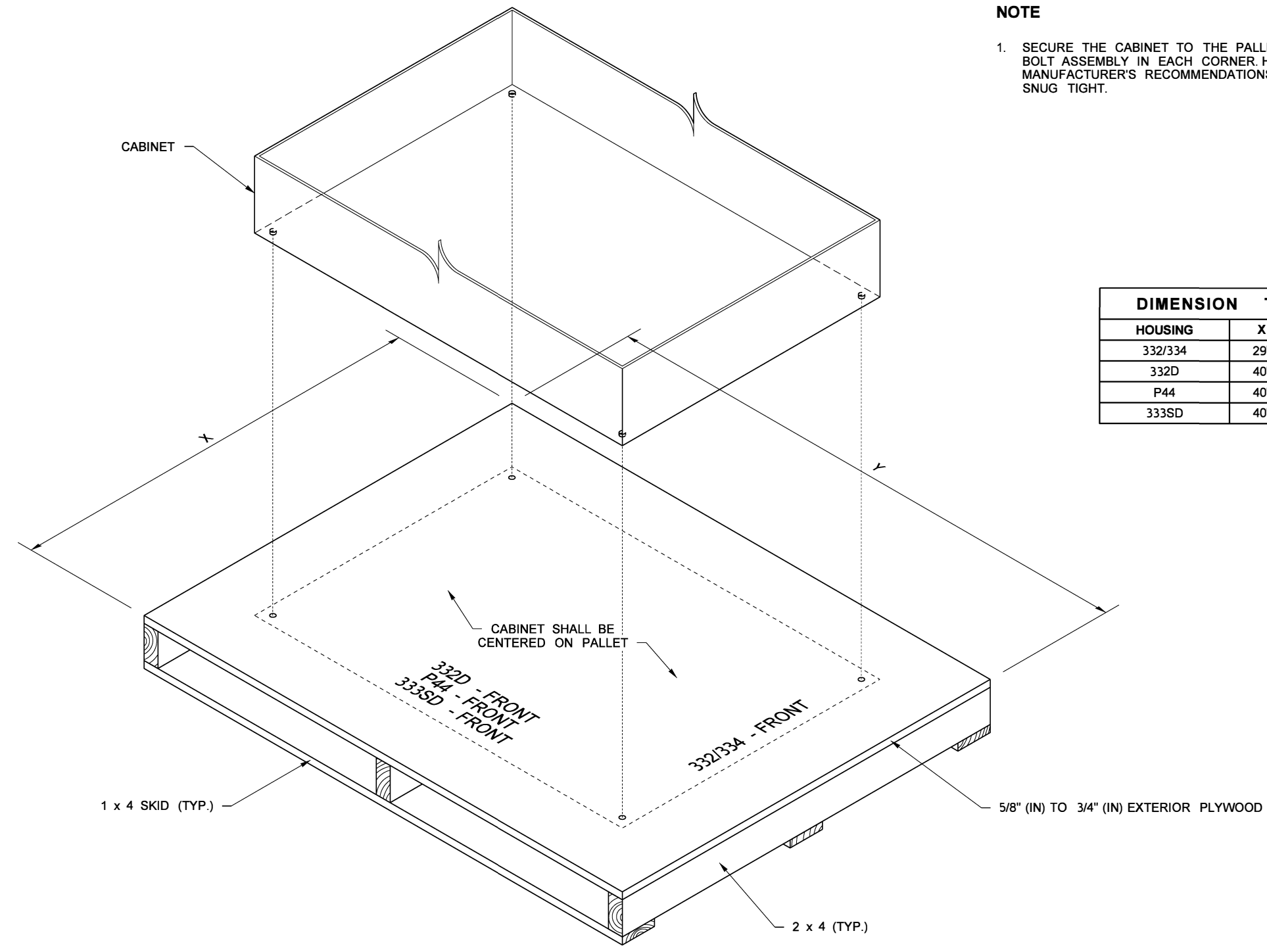

BOLT ASSEMBLY DETAIL

CABINET SHIPPING PALLET

FILE NAME S:\Design R P& S\4-Standards\2-Plan Sheet Library\01-Published PSL(IS) Illumination, Signals, and ITS(IS-10) Cabinet Shipping Pallet\IS-10.dgn				REGION NO.		STATE		FED.AID PROJ.NO.		DATE		DATE		PLOT 1	
TIME 1:36:21 PM				WASH										PLAN REF NO	
DATE 10/6/2014														IS-10	
PLOTTED BY FletcCo				JOB NUMBER										SHEET	
DESIGNED BY				CONTRACT NO.		LOCATION NO.								1	
ENTERED BY														OF	
CHECKED BY														1	
PROJ. ENGR.														SHEETS	
REGIONAL ADM.				REVISION		DATE		BY		P.E. STAMP BOX		P.E. STAMP BOX		CABINET SHIPPING PALLET	

