

ISOMETRIC VIEW

TYPICAL SHOULDER INSTALLATION

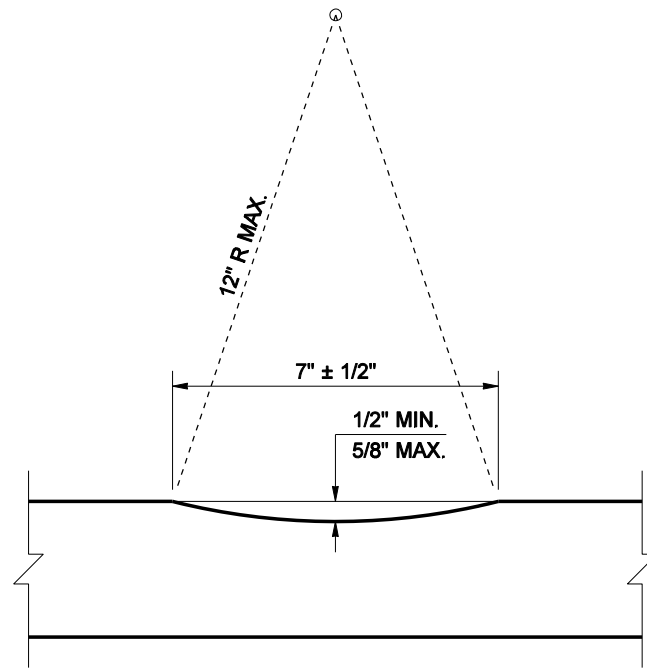

SECTION A

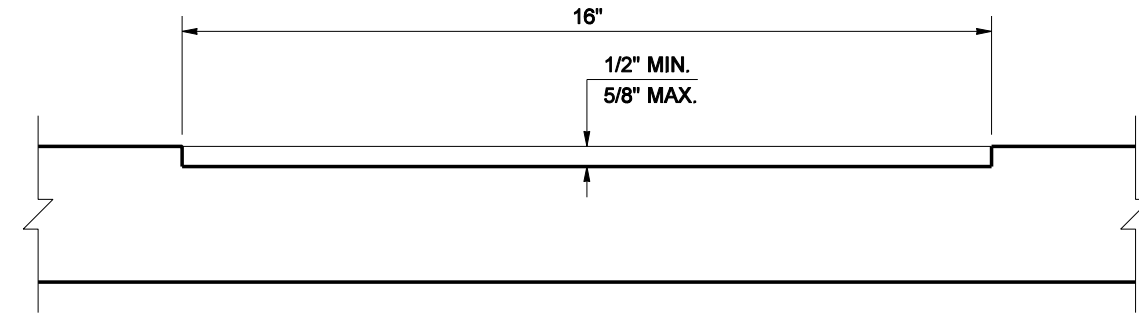

SECTION B

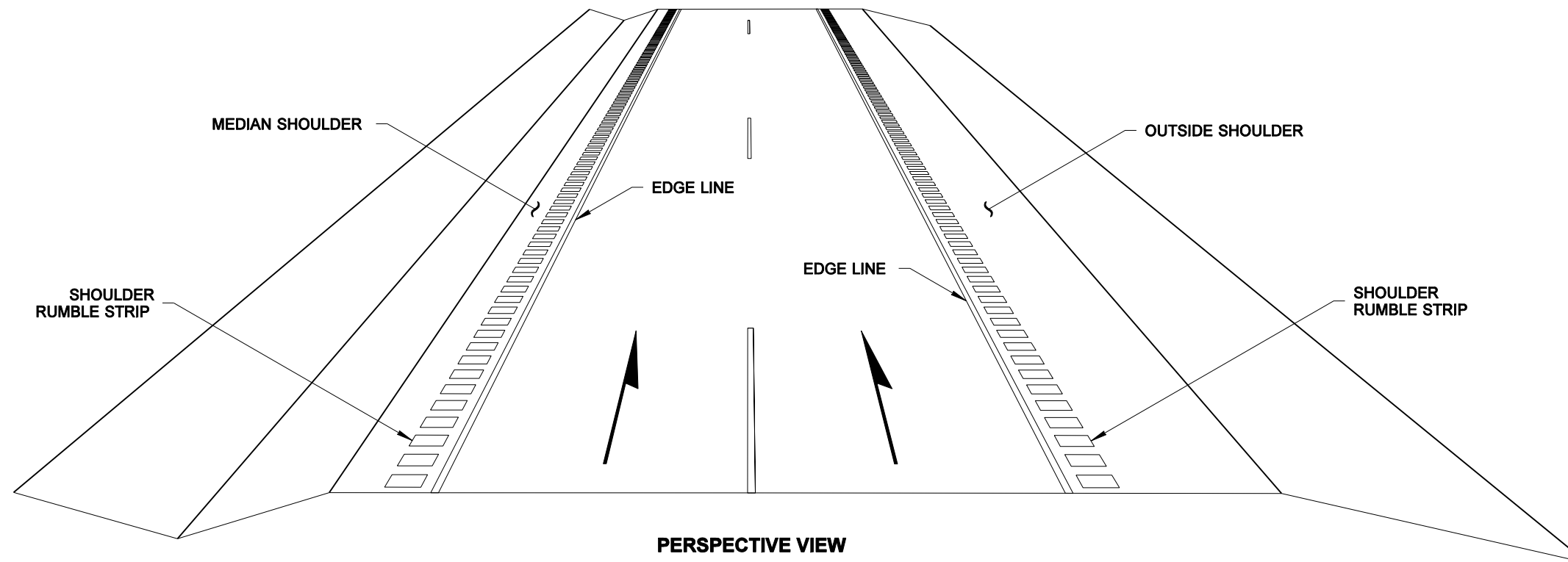

PERSPECTIVE VIEW

MULTI-LANE DIVIDED HIGHWAY

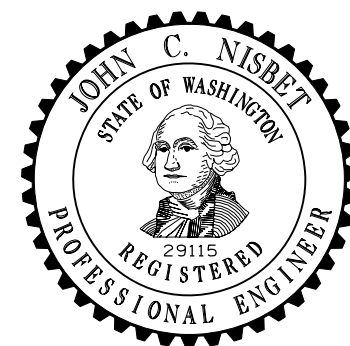

NOTE: THIS PLAN IS NOT A LEGAL ENGINEERING DOCUMENT  
 BUT IS BEING SUBMITTED FOR RECORD. IT IS NOT TO BE USED FOR  
 THE ENGINEERING OR PROPOSED OR EXISTING CONDITIONS. SEE FOR  
 FILE AT THE WASHINGTON STATE DEPARTMENT OF TRANSPORTATION. A COPY MAY BE OBTAINED UPON REQUEST.

**SHOULDER RUMBLE STRIP  
 TYPE 1  
 FOR DIVIDED HIGHWAYS  
 STANDARD PLAN M-60.10-01**

SHEET 1 OF 4 SHEETS

APPROVED FOR PUBLICATION

**Pasco Bakotich III** 06-03-11  
 STATE DESIGN ENGINEER DATE



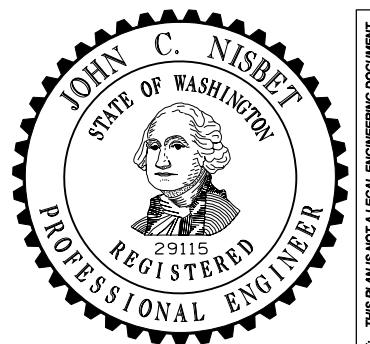
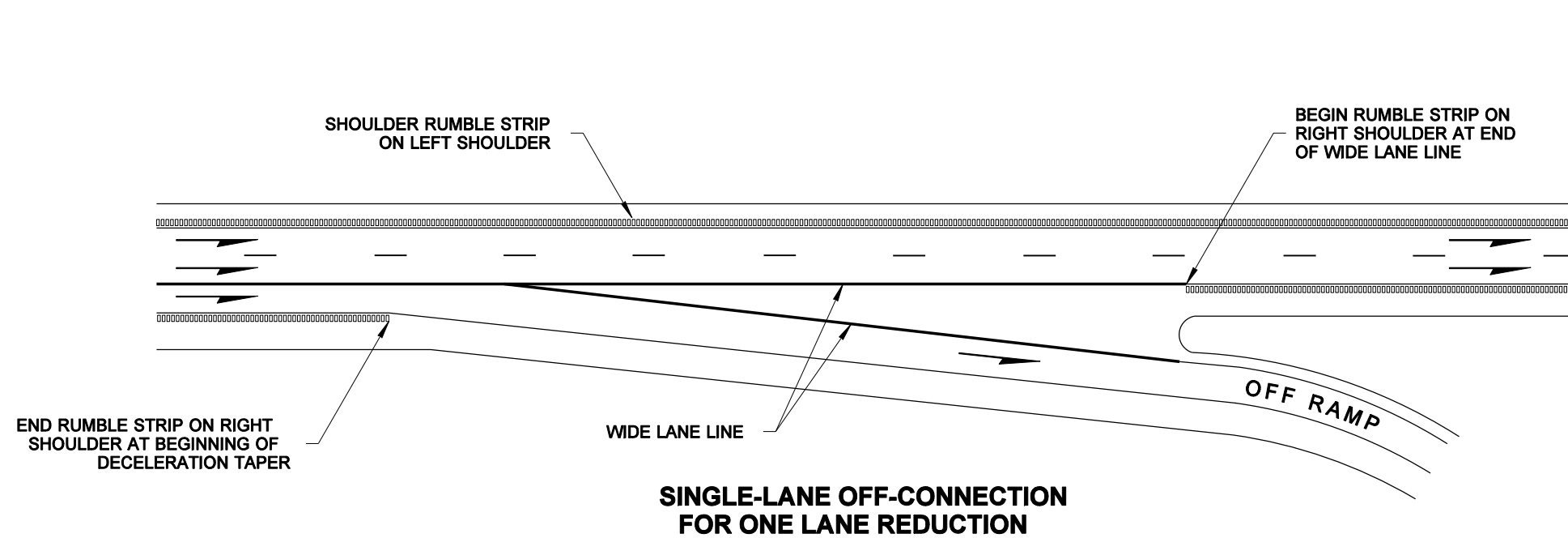
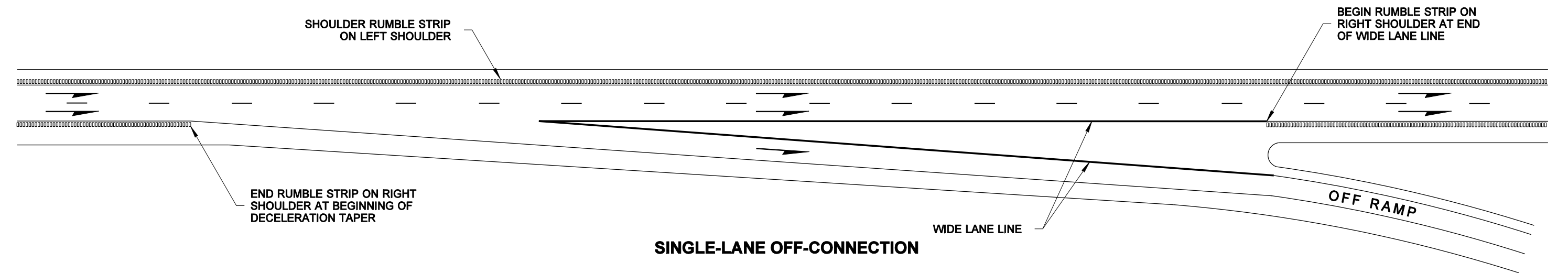
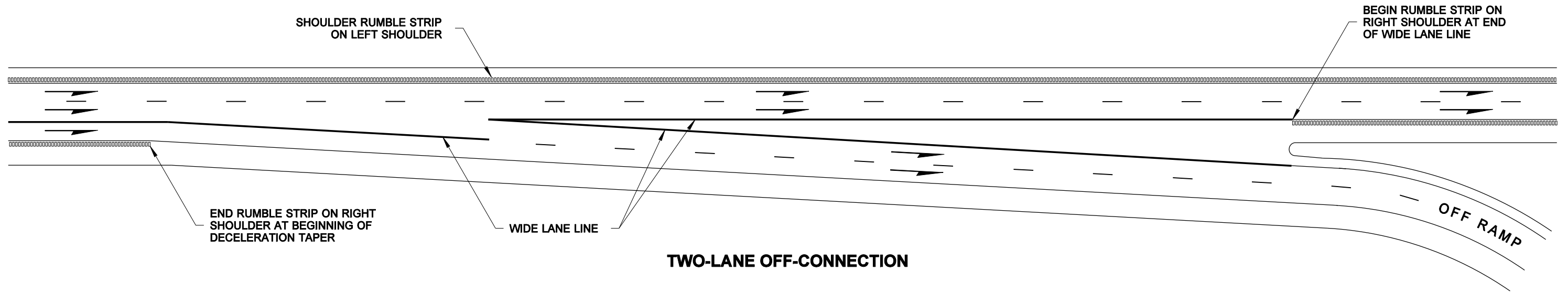

NOTE: THIS PLAN IS NOT A LEGAL ENGINEERING DOCUMENT UNTIL IT IS APPROVED AND SEALED BY THE ENGINEER AND APPROVED BY THE BOARD OF ENGINEERS. THE ENGINEER MUST FILE THIS PLAN WITH THE WASHINGTON STATE DEPARTMENT OF TRANSPORTATION. A COPY MAY BE OBTAINED UPON REQUEST.

**SHOULDER RUMBLE STRIP TYPE 1 FOR DIVIDED HIGHWAYS STANDARD PLAN M-60.10-01**

SHEET 2 OF 4 SHEETS

APPROVED FOR PUBLICATION

**Pasco Bakotich III** 06-03-11  
STATE DESIGN ENGINEER DATE



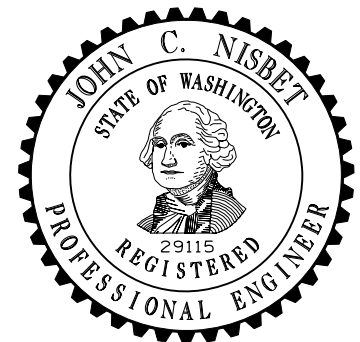
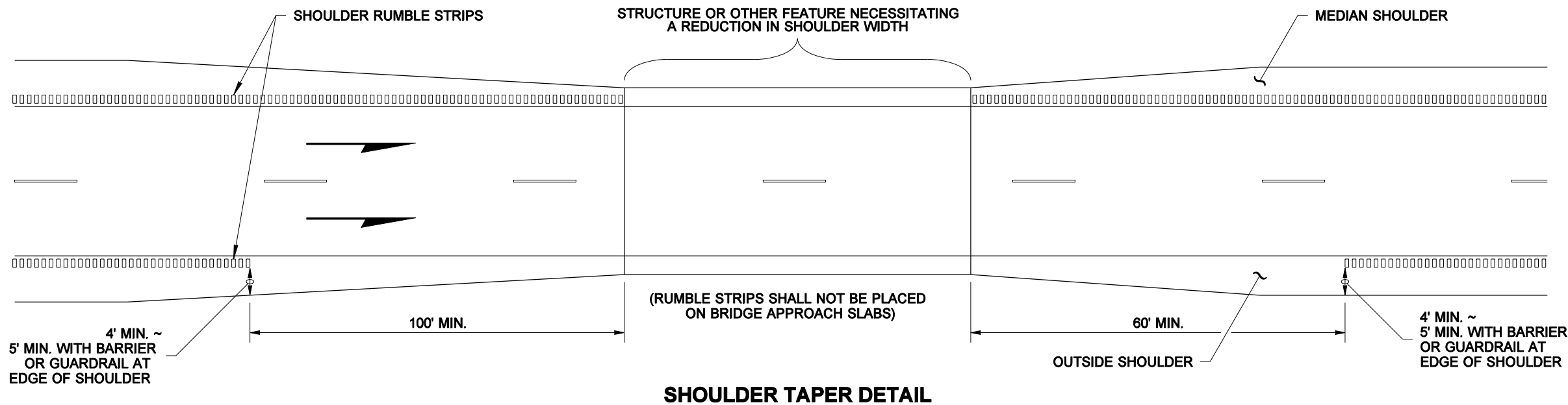
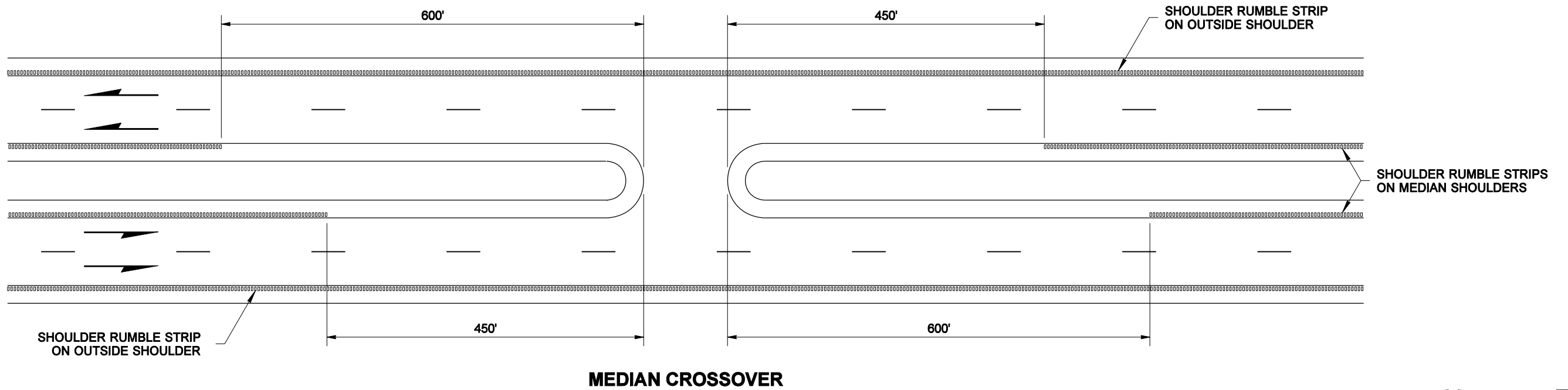
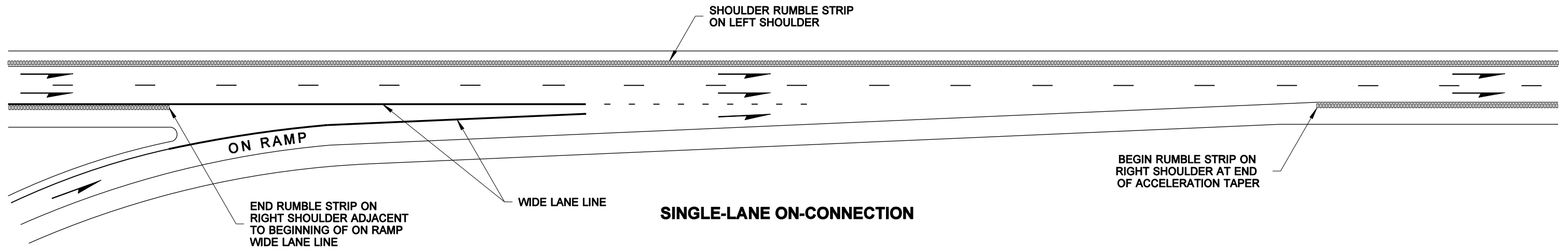

NOTE: THIS PLAN IS NOT A LEGAL ENGINEERING DOCUMENT UNLESS ELECTRONICALLY SIGNED BY THE ENGINEER AND APPROVED BY THE BOARD OF ENGINEERS. THE ENGINEER SHALL FILE THIS DOCUMENT WITH THE STATE DEPARTMENT OF TRANSPORTATION. A COPY MAY BE OBTAINED UPON REQUEST.

**SHOULDER RUMBLE STRIP  
TYPE 1  
FOR DIVIDED HIGHWAYS  
STANDARD PLAN M-60.10-01**

SHEET 3 OF 4 SHEETS

APPROVED FOR PUBLICATION

**Pasco Bakotich III** 06-03-11  
STATE DESIGN ENGINEER DATE



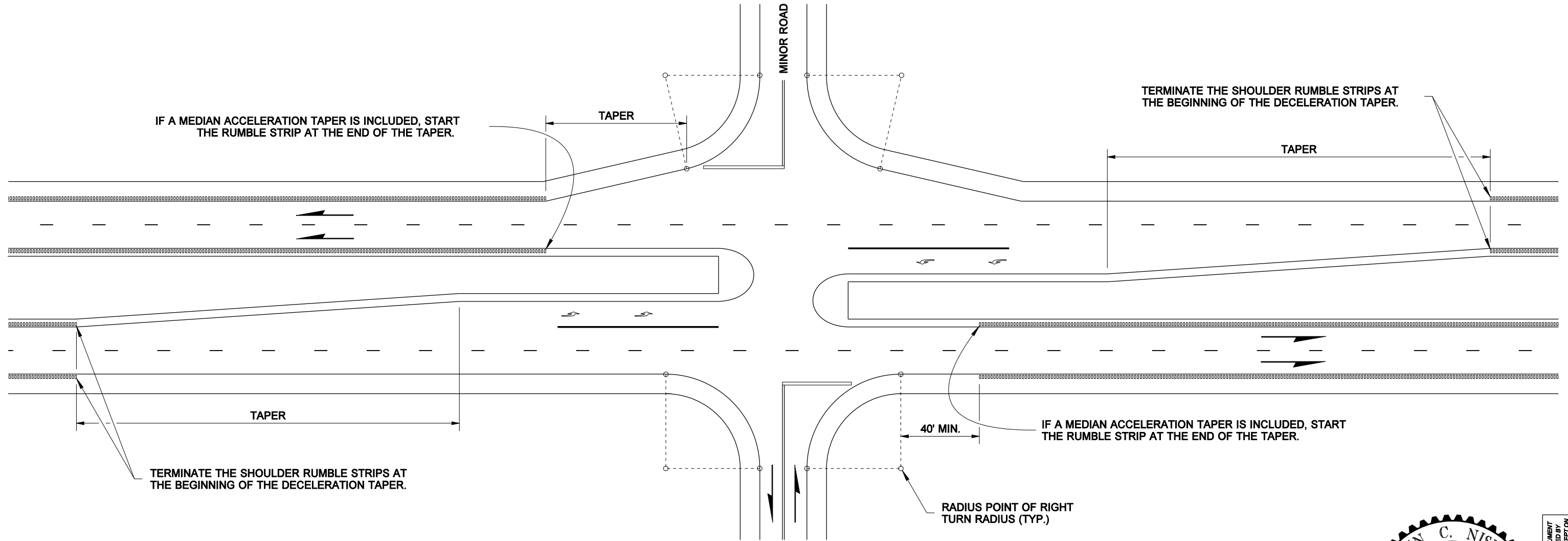

**RUMBLE STRIP PLACEMENT AT INTERSECTIONS**

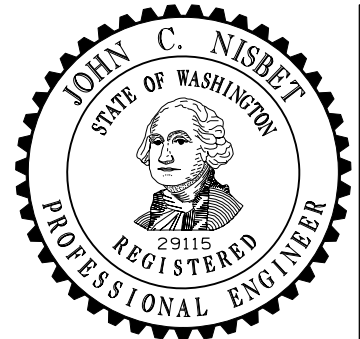

NOTE: THIS PLAN IS NOT A LEGAL ENGINEERING DOCUMENT  
 UNLESS IT IS APPROVED AND SEALED BY THE ENGINEER.  
 THE ENGINEER HAS REVIEWED THIS DOCUMENT AND IS FILED AT THE WASHINGTON STATE DEPARTMENT OF TRANSPORTATION. A COPY MAY BE OBTAINED UPON REQUEST.

**SHOULDER RUMBLE STRIP  
 TYPE 1  
 FOR DIVIDED HIGHWAYS  
 STANDARD PLAN M-60.10-01**

SHEET 4 OF 4 SHEETS

APPROVED FOR PUBLICATION

**Pasco Bakotich III**      **06-03-11**  
 STATE DESIGN ENGINEER      DATE

Washington State Department of Transportation