

DRAWN BY: LISA CYFORD

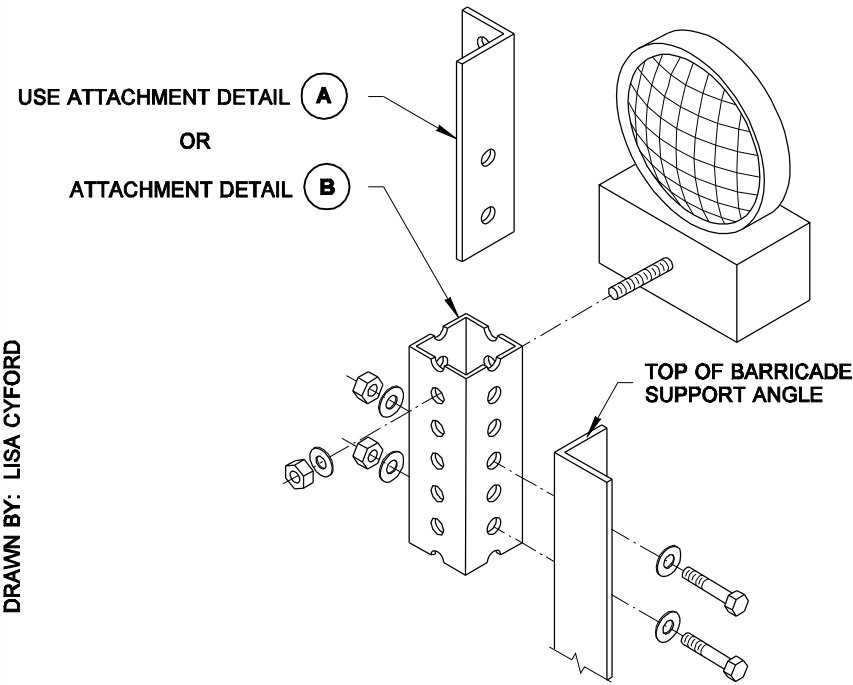

**WARNING LIGHT ATTACHMENT DETAIL**

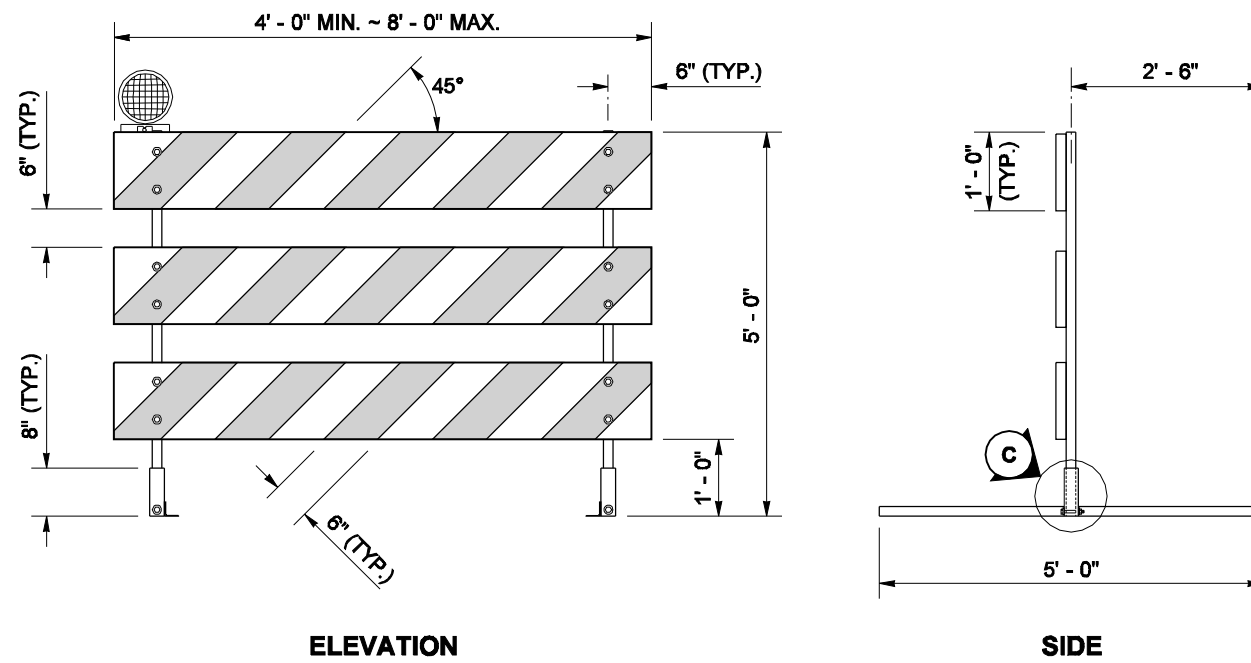

**TYPE 3 BARRICADE**

**NOTES**

1. All fasteners may be zinc plated, galvanized or stainless steel. All steel angle and tubular steel shall be hot-rolled, high carbon steel, painted or galvanized.
2. Install one lightweight Type A Low-Intensity flashing warning light on the traffic side of the barricade. Install two Type A Low-Intensity flashing warning lights per barricade when the barricades are used to close a roadway. Attach the light to the barricade according to the light manufacturer's recommendations or use the details shown on this plan.
3. Stripes on barricade rails shall be alternating orange and white retroreflective stripes (sloping downward at an angle of 45 degrees in the direction traffic is to pass).
4. The Type 3 barricade design shown on this plan meets the crash test requirements of NCHRP 350. Alternative designs may be approved if they conform to the NCHRP 350 crash test criteria and the MUTCD.
5. When a sign is mounted on the barricade, it shall be securely bolted to at least two plywood panels. The top of the sign shall not be higher than the top panel of the barricade.
6. When sandbags are used in freezing weather, Urea fertilizer shall be mixed with the sand in a quantity to prevent the sand from freezing.

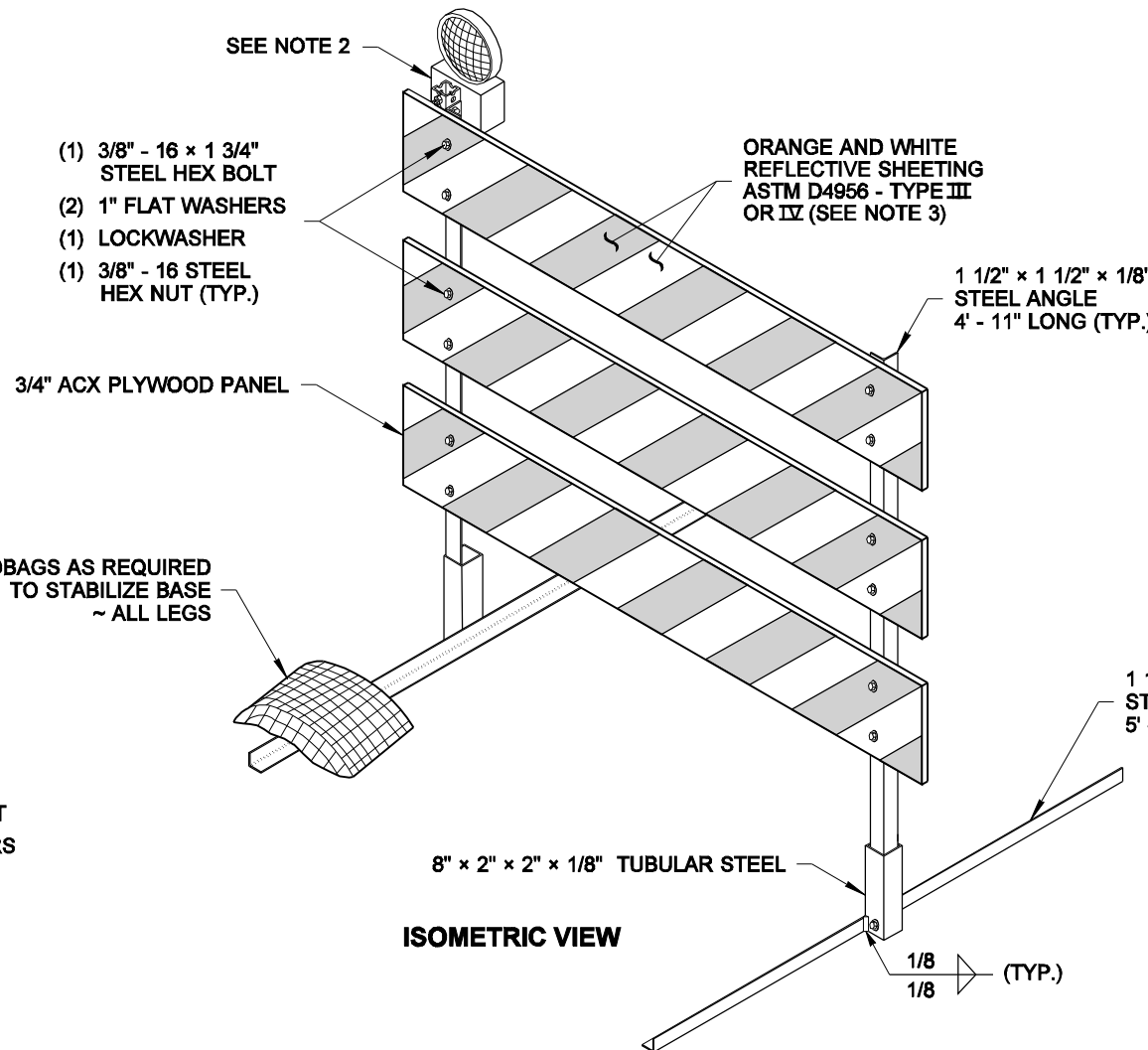
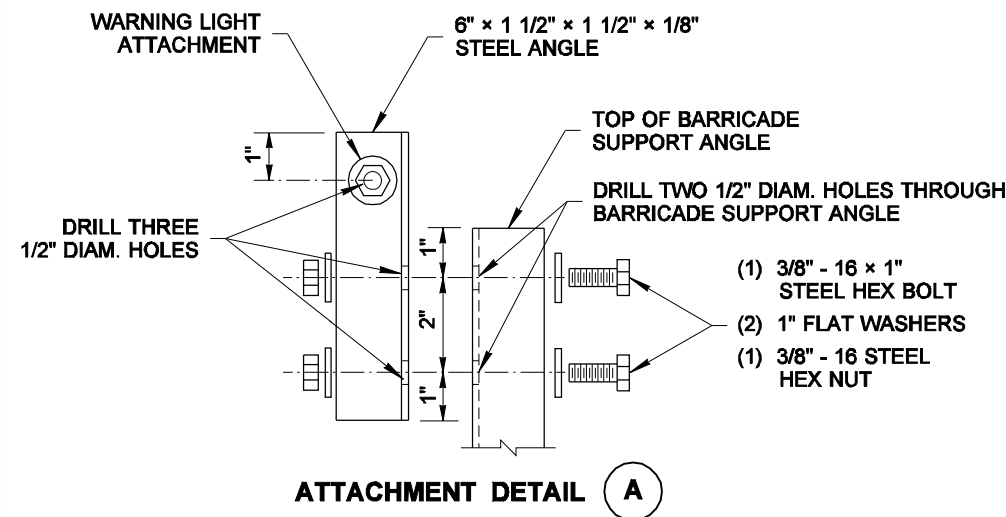

**ISOMETRIC VIEW**

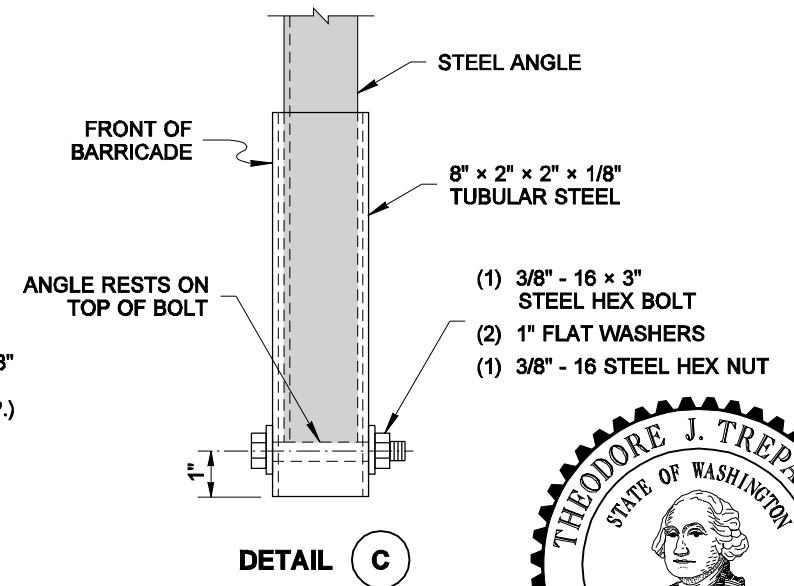

EXPIRES AUGUST 9, 2007

**TYPE 3 BARRICADE**  
**STANDARD PLAN K-80.20-00**  
SHEET 1 OF 2 SHEETS

APPROVED FOR PUBLICATION

**Kevin J. Dayton** 12-20-06  
STATE DESIGN ENGINEER DATE



NOTE: THIS PLAN IS NOT A LEGAL ENGINEERING DOCUMENT UNTIL AN ELECTRONIC OR ORIGINAL COPY IS FILED AT THE WASHINGTON STATE DEPARTMENT OF TRANSPORTATION. A COPY MAY BE OBTAINED UPON REQUEST.

DRAWN BY: LISA CYFORD

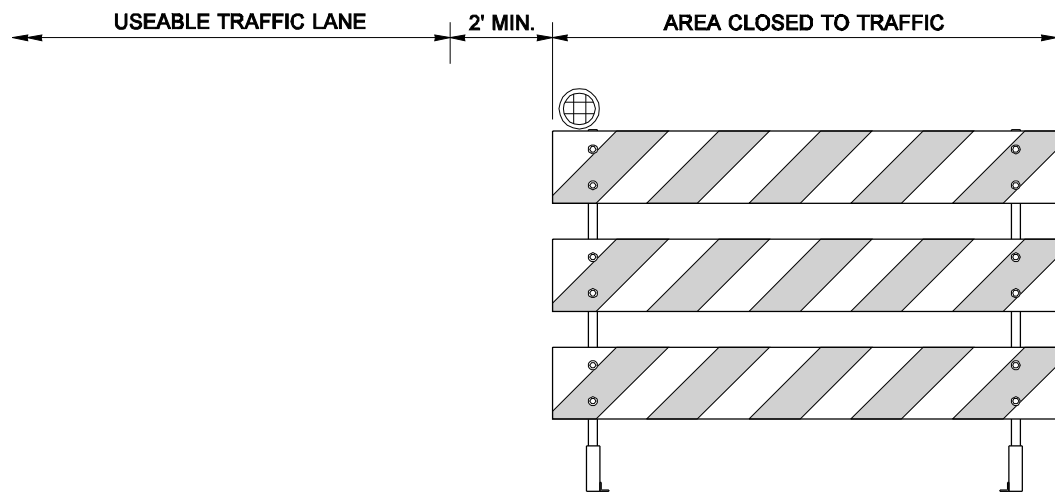

**TYPE 3L BARRICADE**

STRIPES ON THE BARRICADES SHALL SLOPE DOWNWARD IN THE DIRECTION TRAFFIC IS TO PASS

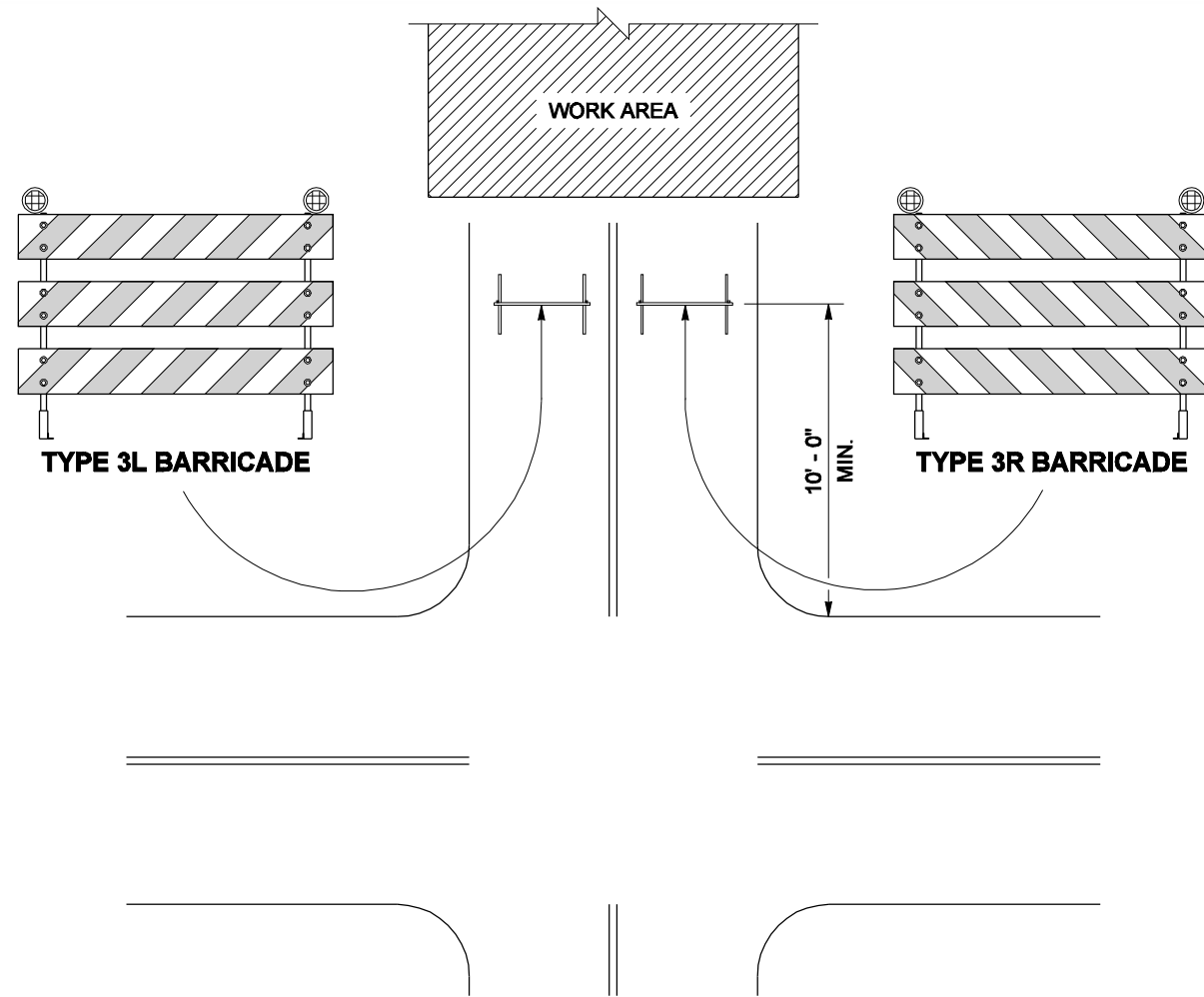

**ROAD CLOSURE AT INTERSECTION**

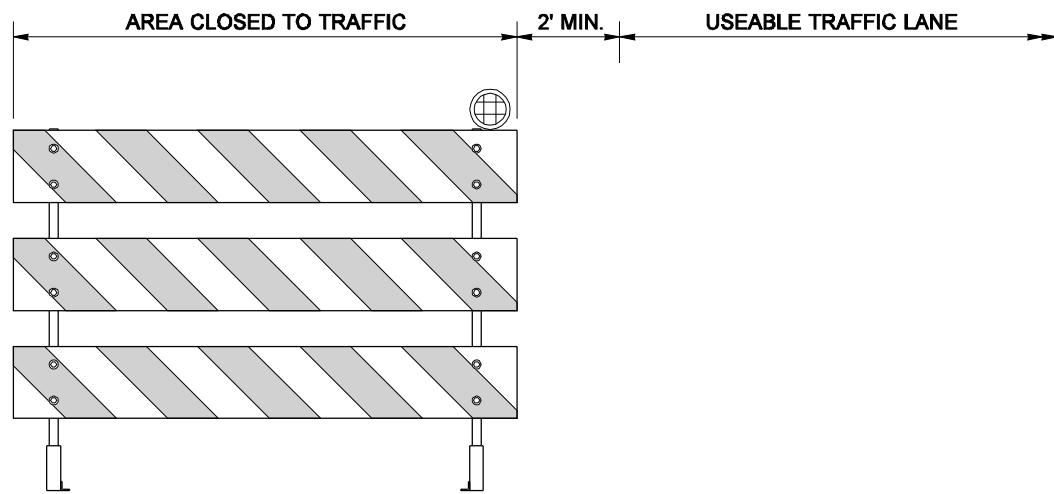

**TYPE 3R BARRICADE**

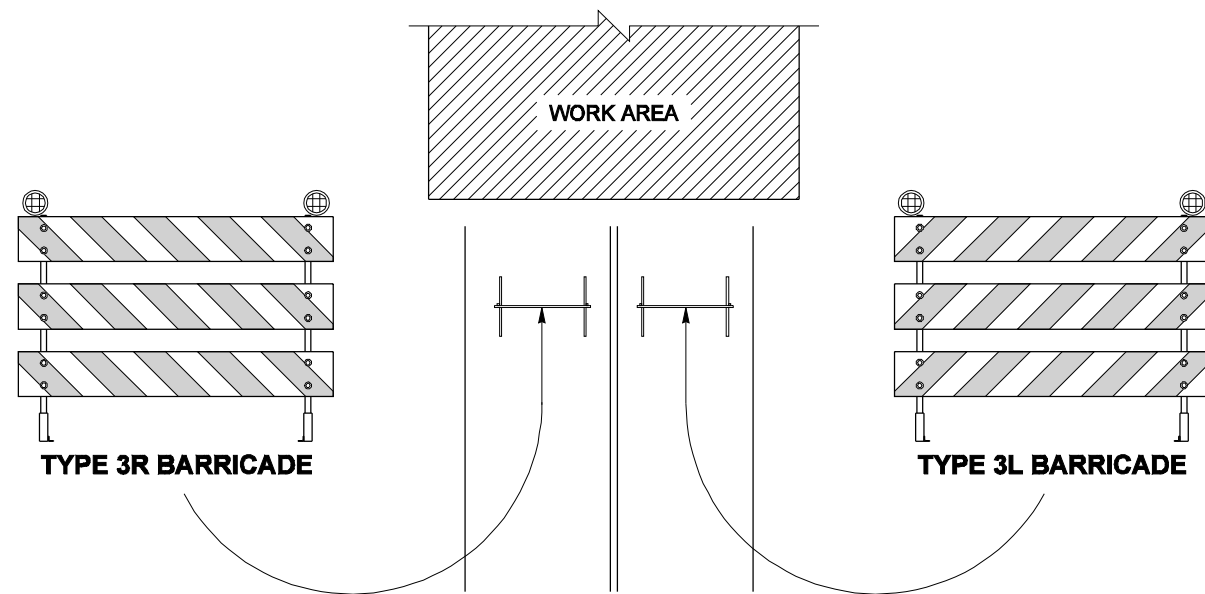

**ROAD CLOSURE AT OTHER LOCATIONS**

**BARRICADE PLACEMENT**

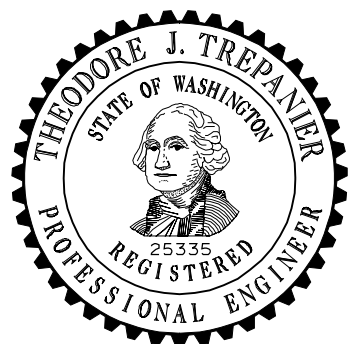

EXPIRES AUGUST 9, 2007

NOTE: THIS PLAN IS NOT A LEGAL ENGINEERING DOCUMENT UNTIL AN ELECTRONIC DIGITAL SIGNATURE IS APPLIED TO THE ORIGINAL. THE ORIGINAL, SIGNED BY THE ENGINEER AND APPROVED FOR PUBLICATION, IS KEPT ON FILE AT THE WASHINGTON STATE DEPARTMENT OF TRANSPORTATION. A COPY MAY BE OBTAINED UPON REQUEST.

**TYPE 3 BARRICADE**  
**STANDARD PLAN K-80.20-00**

SHEET 2 OF 2 SHEETS

APPROVED FOR PUBLICATION

**Kevin J. Dayton** 12-20-06

STATE DESIGN ENGINEER DATE

Washington State Department of Transportation