

DRAWN BY: ADAM COCHRAN

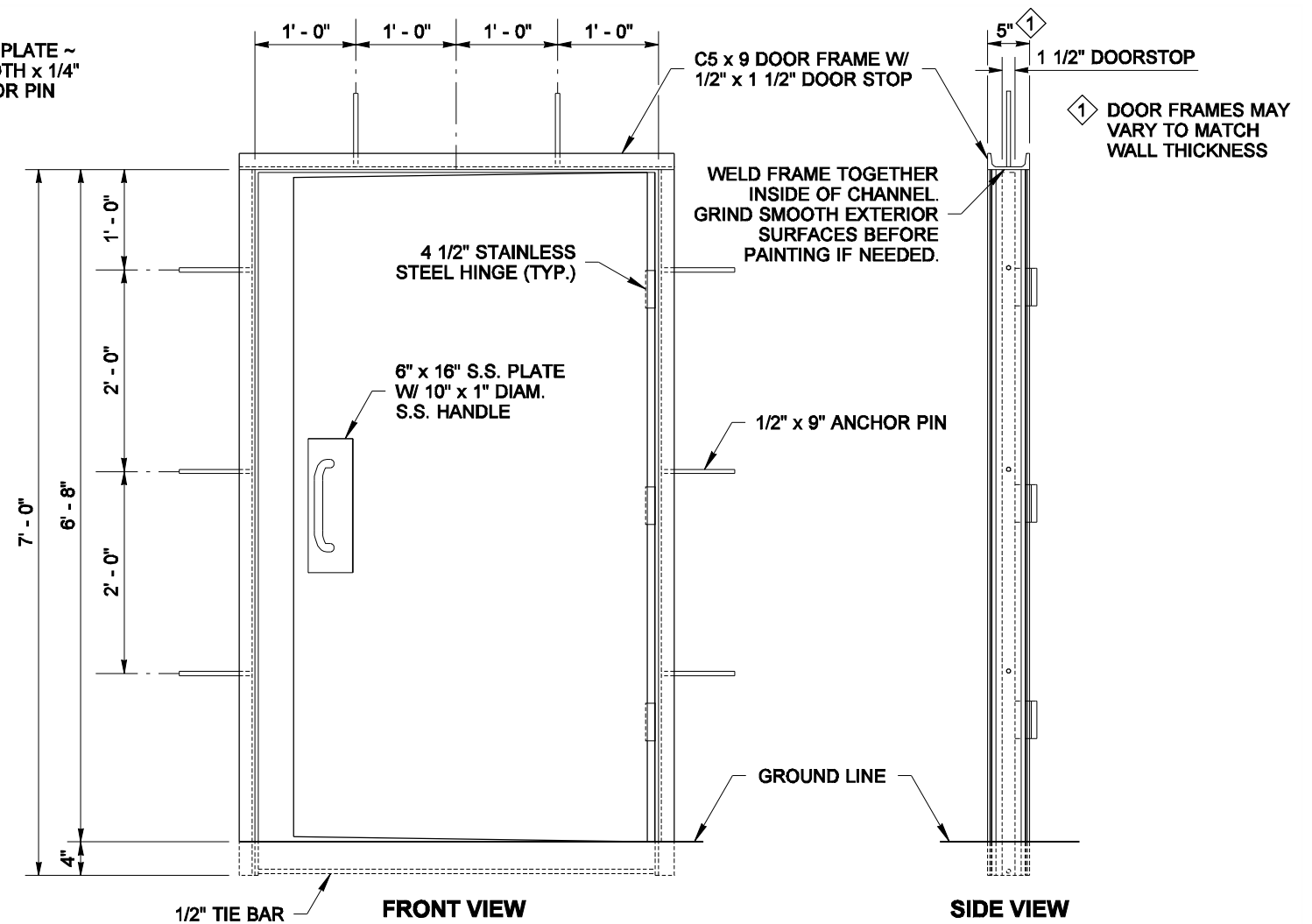

**NOTE**

All exposed metal surfaces shall be painted with paint conforming to the requirements in the Standard Specifications, Section 9.

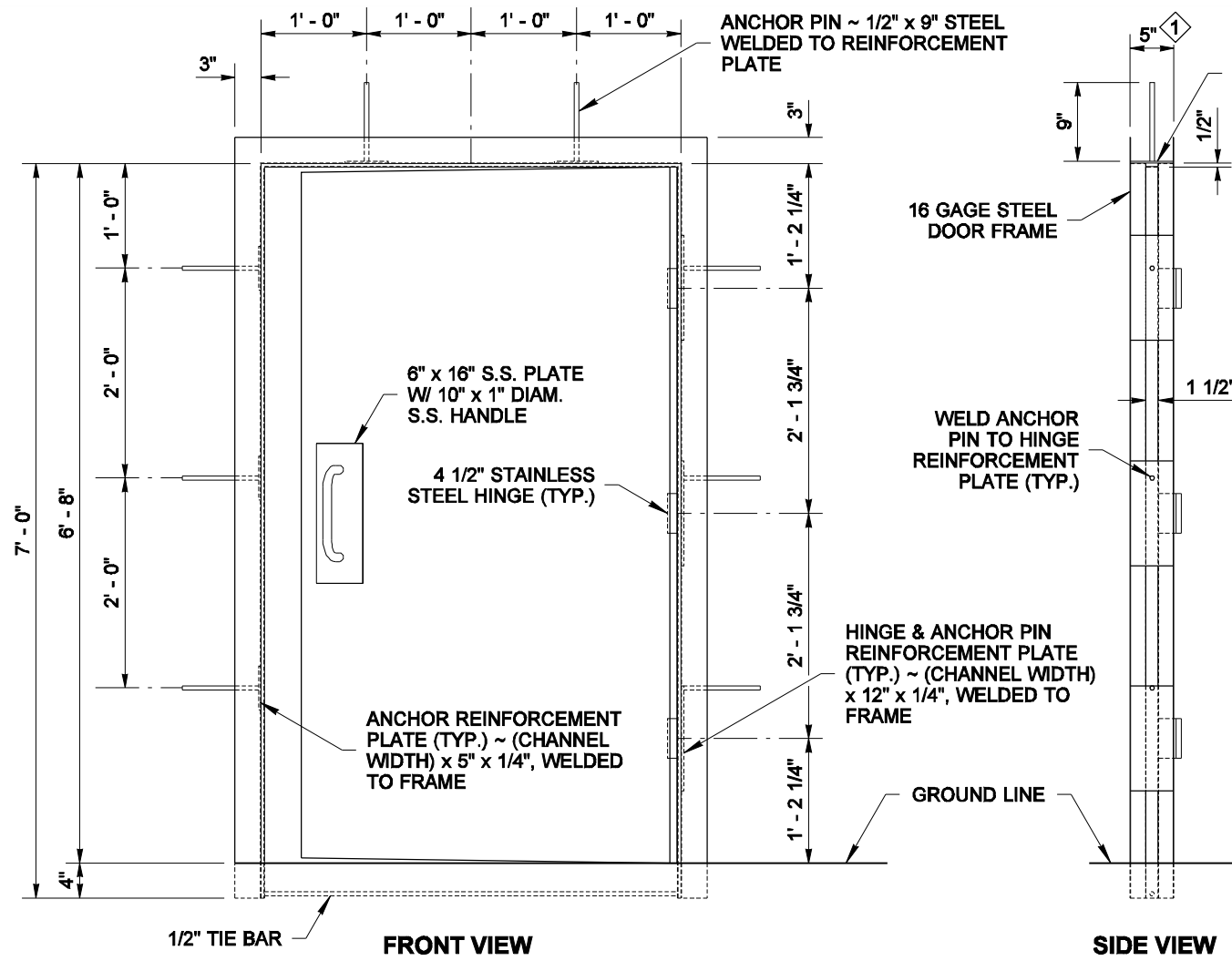
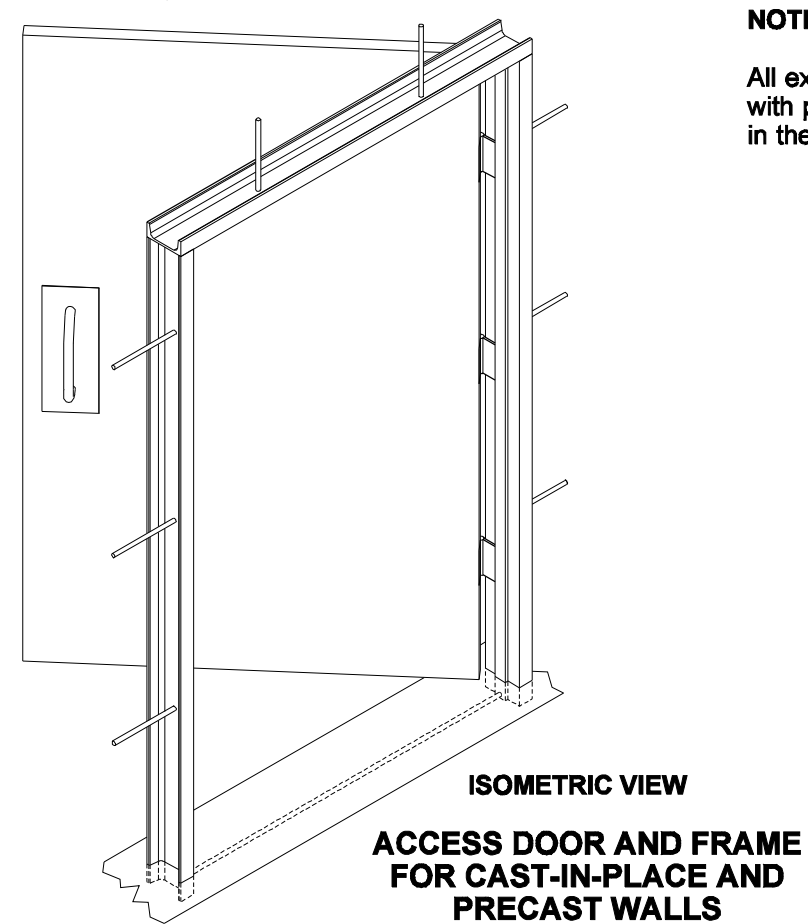
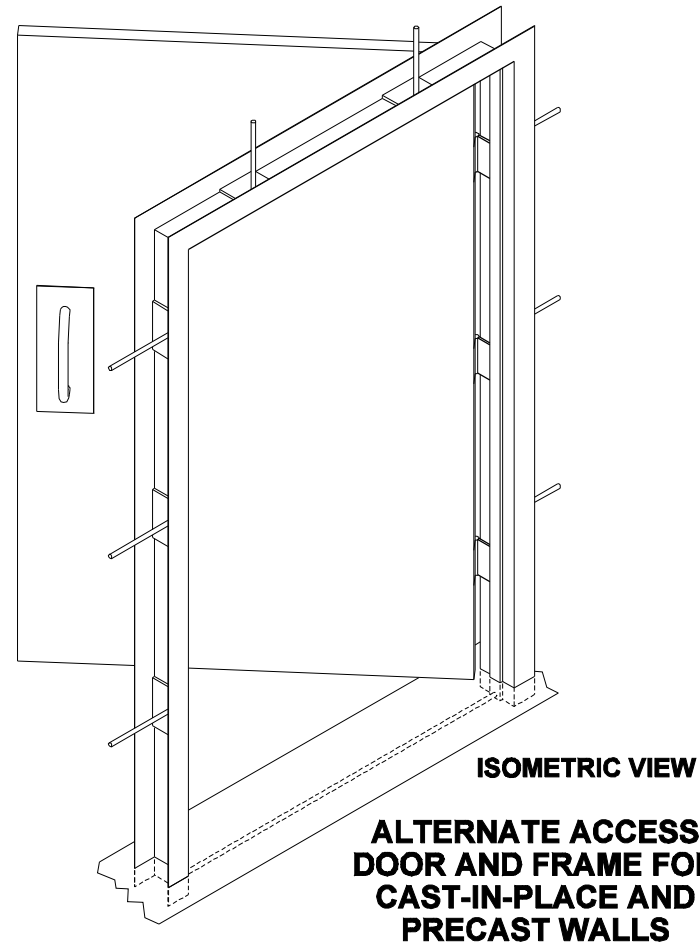

EXPIRES AUGUST 23, 2006

NOTE: THIS PLAN IS NOT A LEGAL ENGINEERING DOCUMENT BUT AN ELECTRONIC DUPLICATE. THE ORIGINAL, SIGNED BY THE ENGINEER AND APPROVED FOR PUBLICATION, IS KEPT ON FILE AT THE WASHINGTON STATE DEPARTMENT OF TRANSPORTATION. A COPY MAY BE OBTAINED UPON REQUEST.

**NOISE BARRIER WALL  
ACCESS DOOR & FRAME  
STANDARD PLAN D-2.92-00**

SHEET 1 OF 2 SHEETS

APPROVED FOR PUBLICATION

**Harold J. Peterfeso** 11-10-05

STATE DESIGN ENGINEER

DATE



Washington State Department of Transportation

DRAWN BY: ADAM COCHRAN

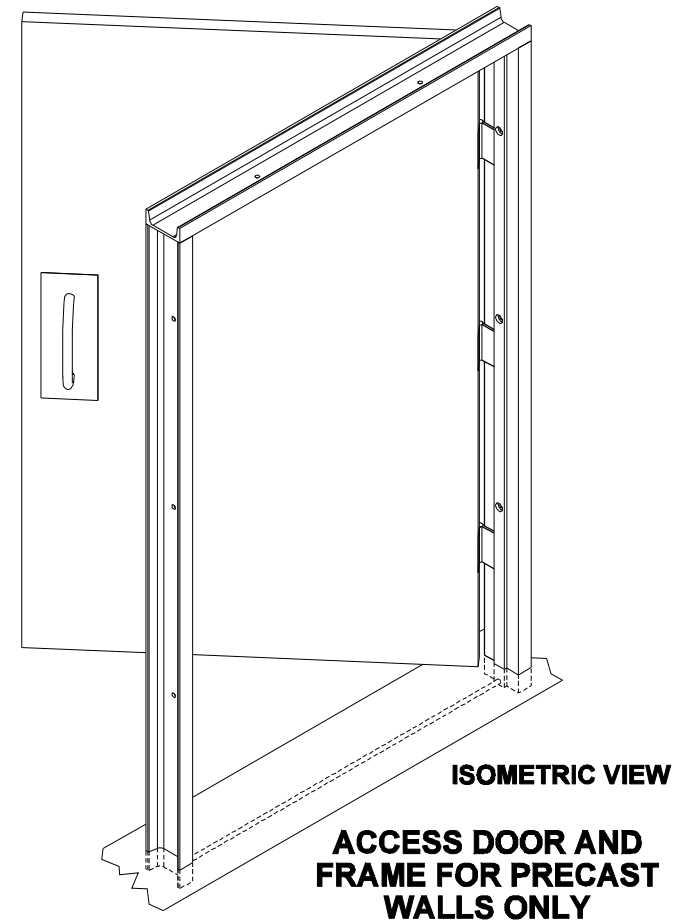
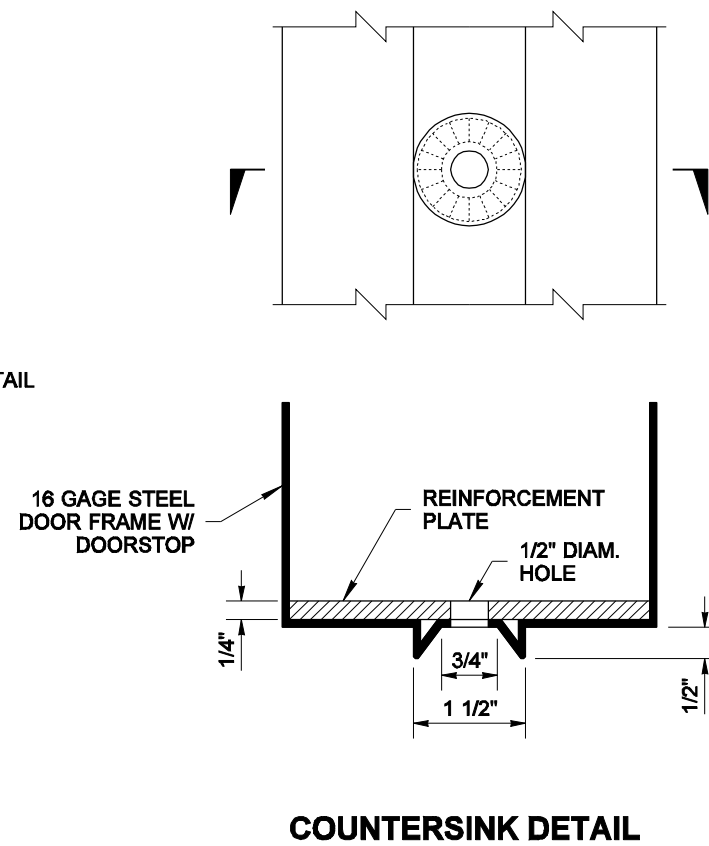
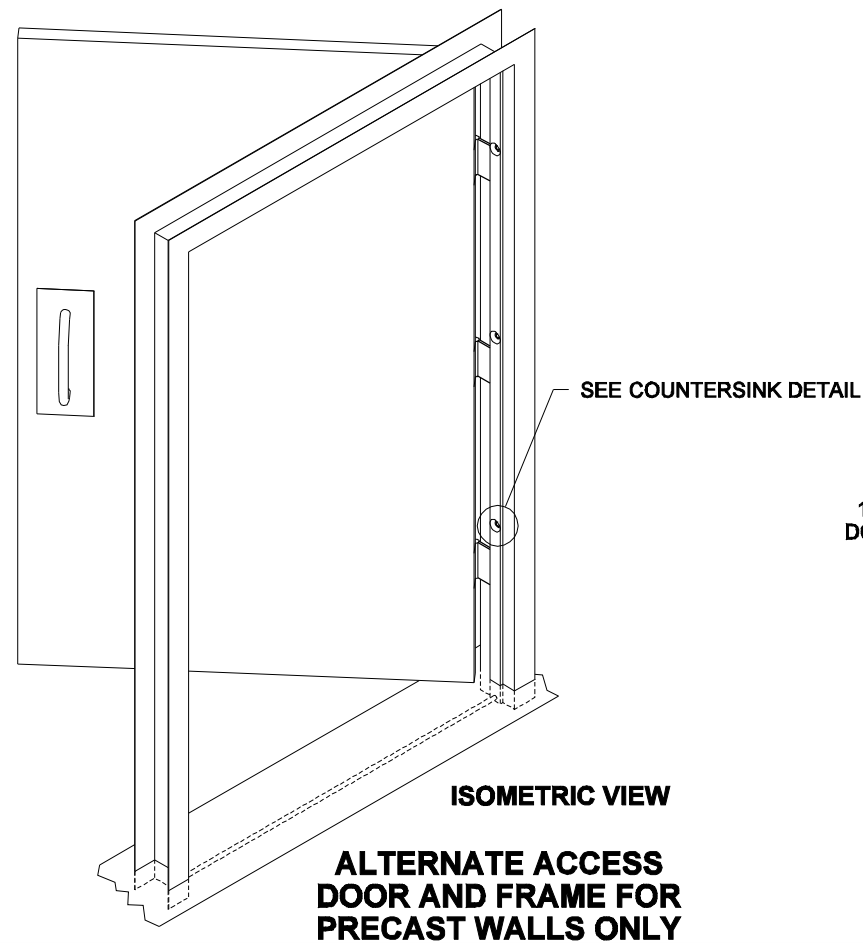
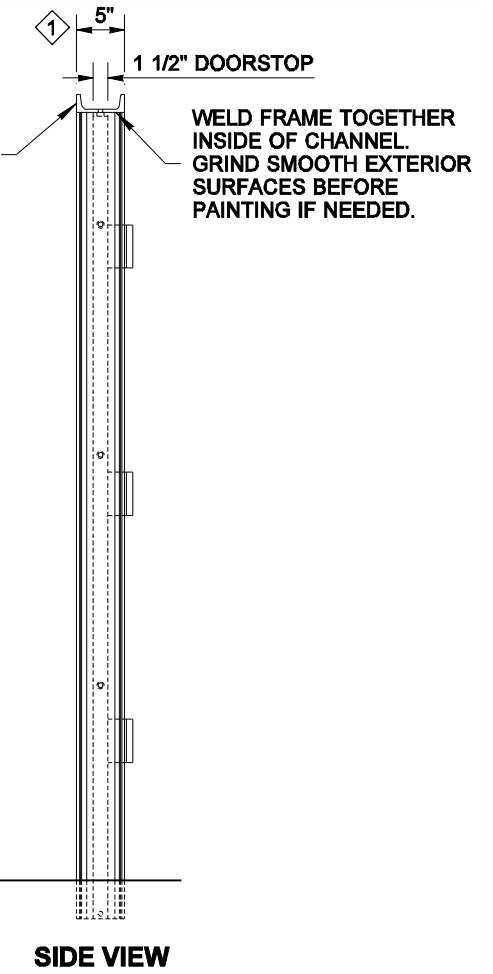
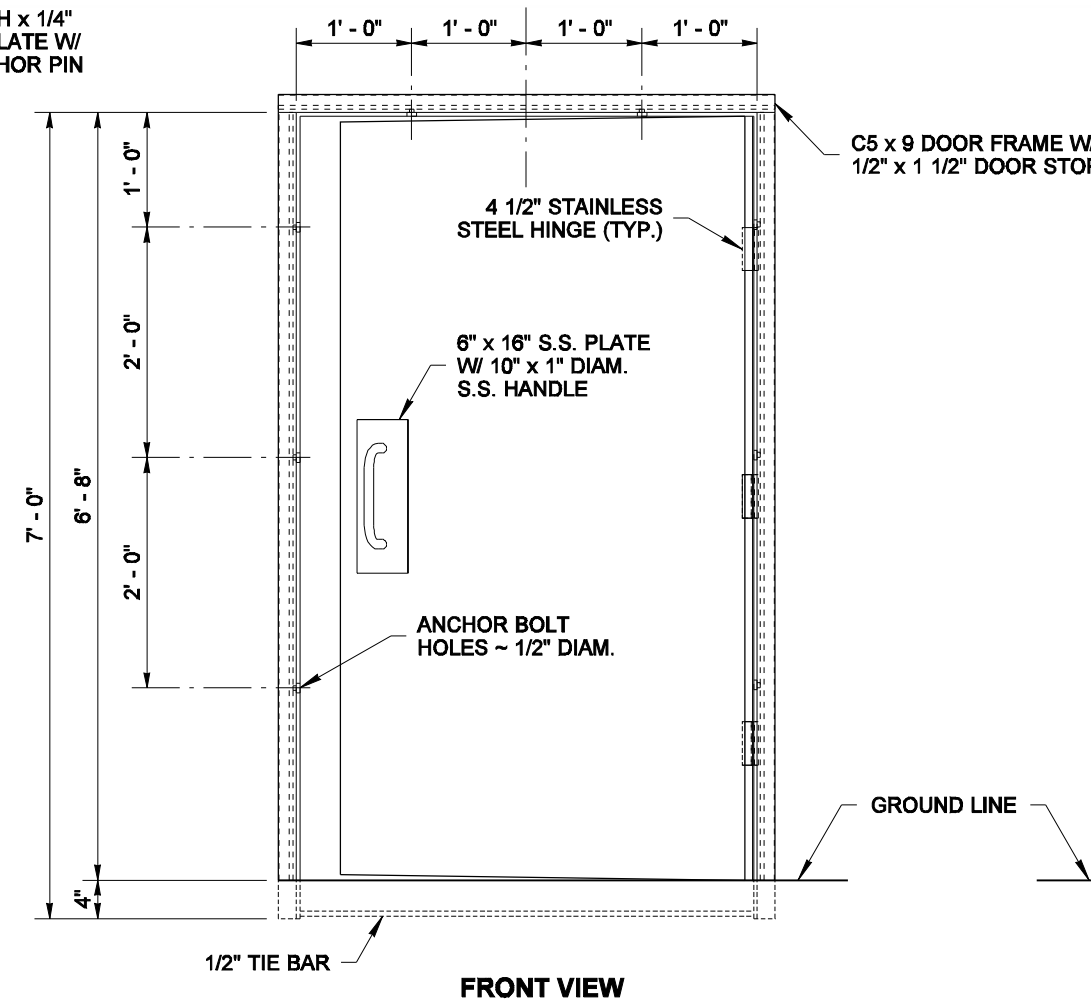
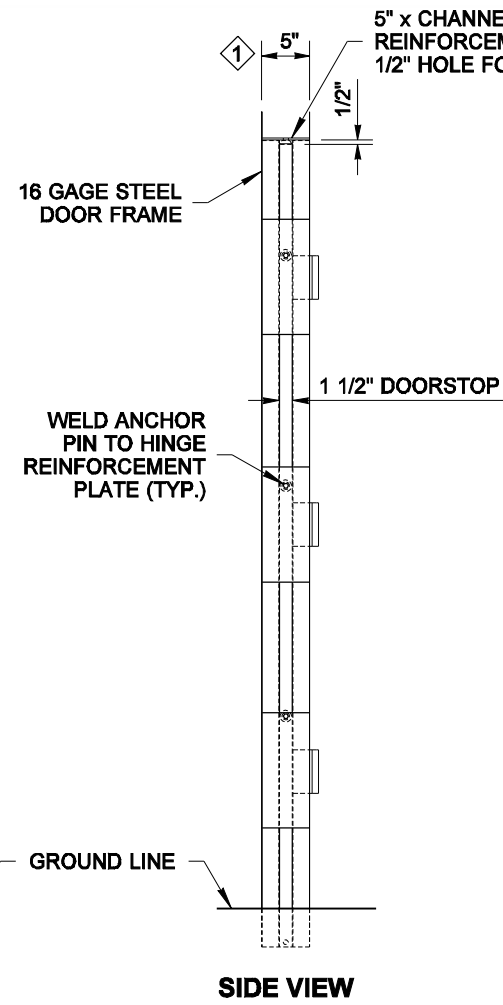
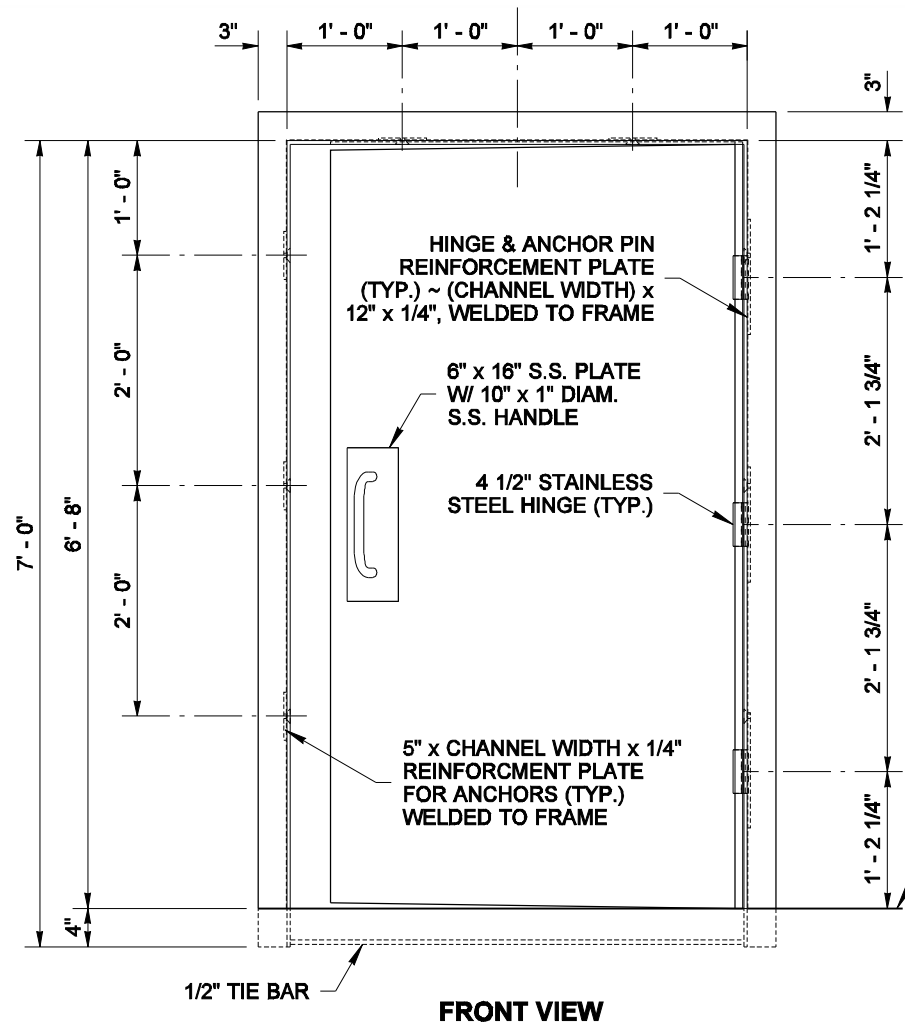

EXPIRES AUGUST 23, 2006

NOTE: THIS PLAN IS NOT A LEGAL ENGINEERING DOCUMENT BUT AN ELECTRONIC DUPLICATE. THE ORIGINAL, SIGNED BY THE ENGINEER AND APPROVED FOR PUBLICATION, IS KEPT ON FILE AT THE WASHINGTON STATE DEPARTMENT OF TRANSPORTATION. A COPY MAY BE OBTAINED UPON REQUEST.

**NOISE BARRIER WALL ACCESS DOOR & FRAME**  
**STANDARD PLAN D-2.92-00**

SHEET 2 OF 2 SHEETS

APPROVED FOR PUBLICATION

**Harold J. Peterfeso** 11-10-05

STATE DESIGN ENGINEER

DATE



Washington State Department of Transportation