

TYPICAL LIVE STAKE INSTALLATION

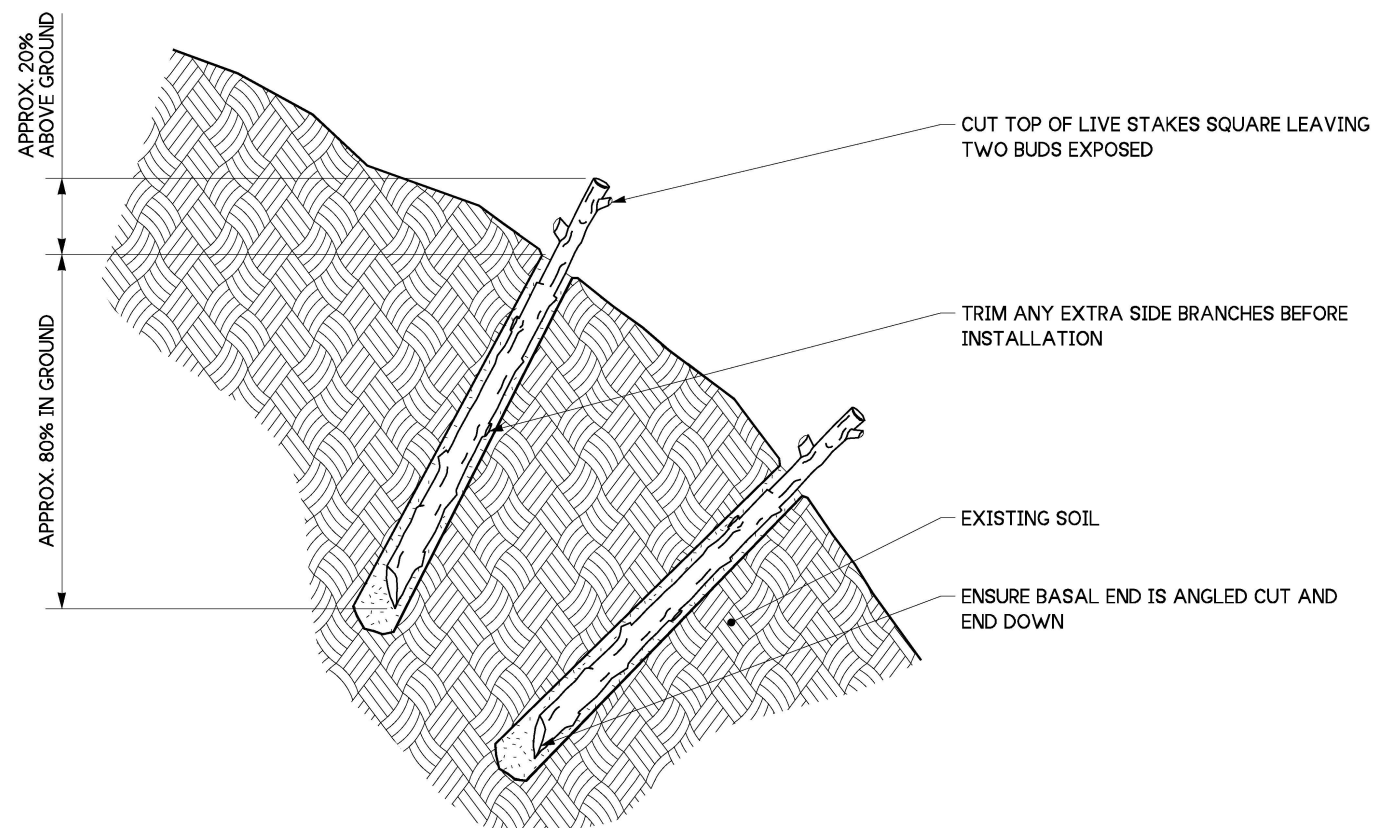

LIVE STAKE INSTALLATION ON SLOPES

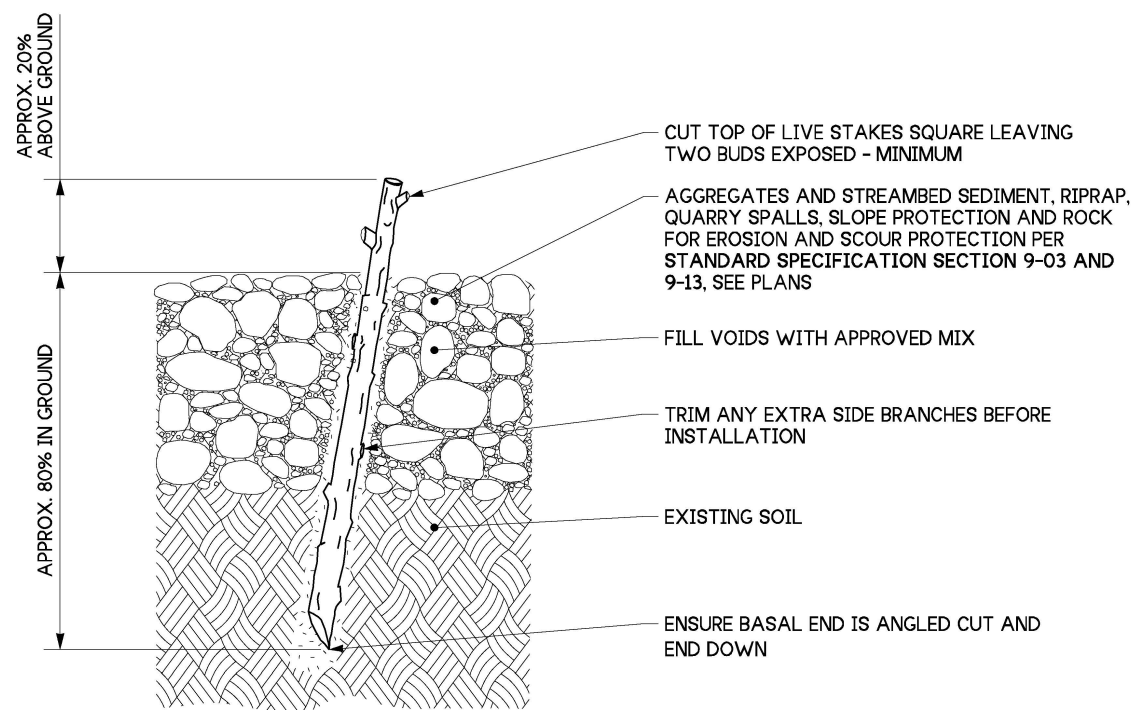

LIVE STAKE INSTALLATION IN ROCK

NOTES:

1. See Standard Specification Sections 8-02.3(8) and 9-14.7.
2. Pre-pilot hole with rebar or star drill no greater than 1/2" (in) size.
3. Install live stakes using hands. Do not hammer directly on live stake.
4. Avoid stripping bark or bruising plant material during installation.
5. Fill voids around hole after installation.
6. Rock type may vary. Refer to plans.
7. See plant material list for species.

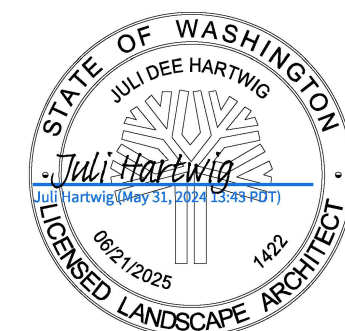

May 31, 2024

LIVE STAKE INSTALLATIONS

STANDARD PLAN H-10.15-01

SHEET 1 OF 1 SHEET

APPROVED FOR PUBLICATION	
<i>Mark A. Davis</i>	Jun 2, 2024
STATE DESIGN ENGINEER	