

ELEVATION

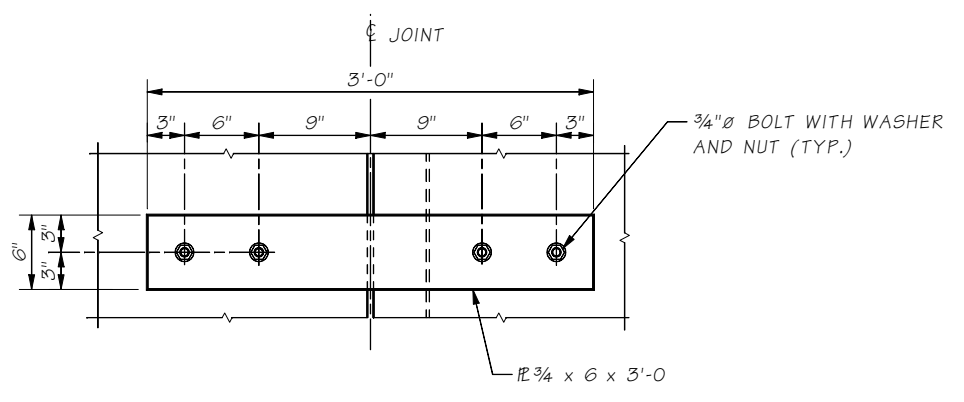

VIEW C
LONGITUDINAL TIE

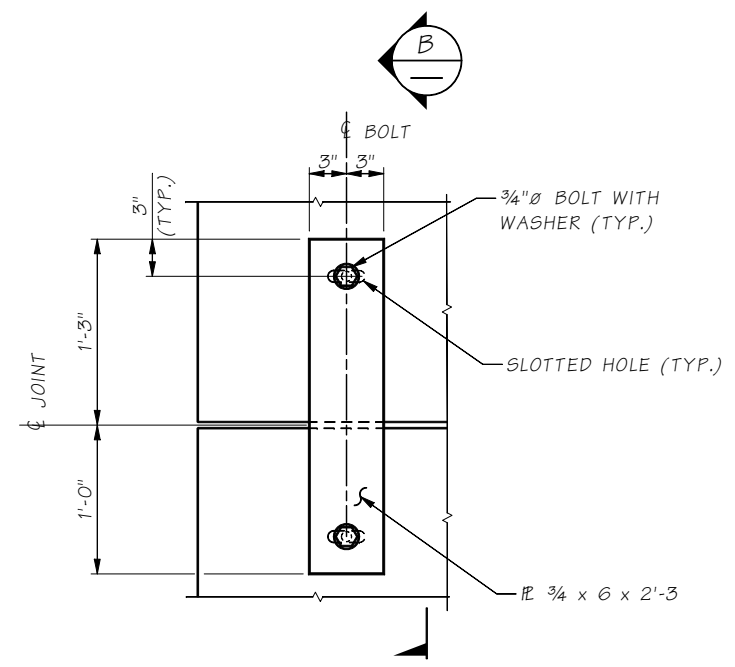

DETAIL 1

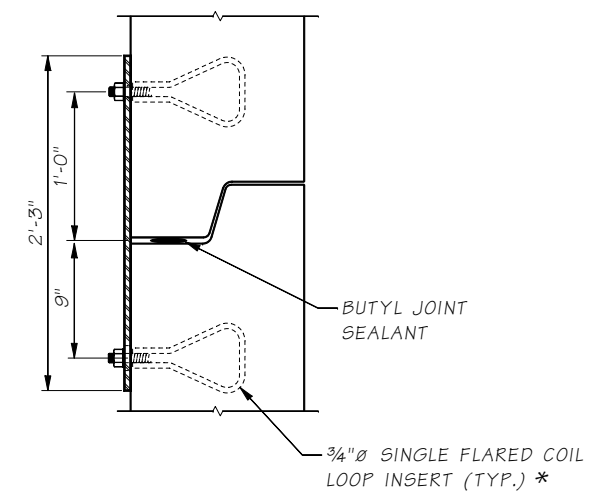

SECTION B
REINFORCING NOT SHOWN FOR CLARITY.

* OTHER ANCHOR DEVICE OR DRILLED HOLE WITH EPOXY RESIN MAY BE USED. SUBMIT DETAILS TO THE ENGINEER FOR APPROVAL.

SR FILE NO. Job SHEET 1

8.3.2-A12

Bridge Design Engr.	M:\STANDARDS\Buried Structures\EXAMPLE PLANS\8.3.2-A12 EXAMPLE OF PRECAST SPLIT BOX CULVERT CONNECTION DETAILS.MAN							
Supervisor				REGION NO.	STATE	FED. AID PROJ. NO.	SHEET NO.	TOTAL SHEETS
Designed By				10	WASH.			
Checked By				JOB NUMBER				
Bridge Projects Engr.								
Prelim. Plan By								
Architect/Specialist	DATE	REVISION	BY	APPD				

BRIDGE AND STRUCTURES OFFICE



BRIDGE SHEET NO.
SHEET
OF
SHEETS

EXAMPLE OF PRECAST SPLIT BOX CULVERT CONNECTION DETAILS