

LAST REVISED: 06/09/2025

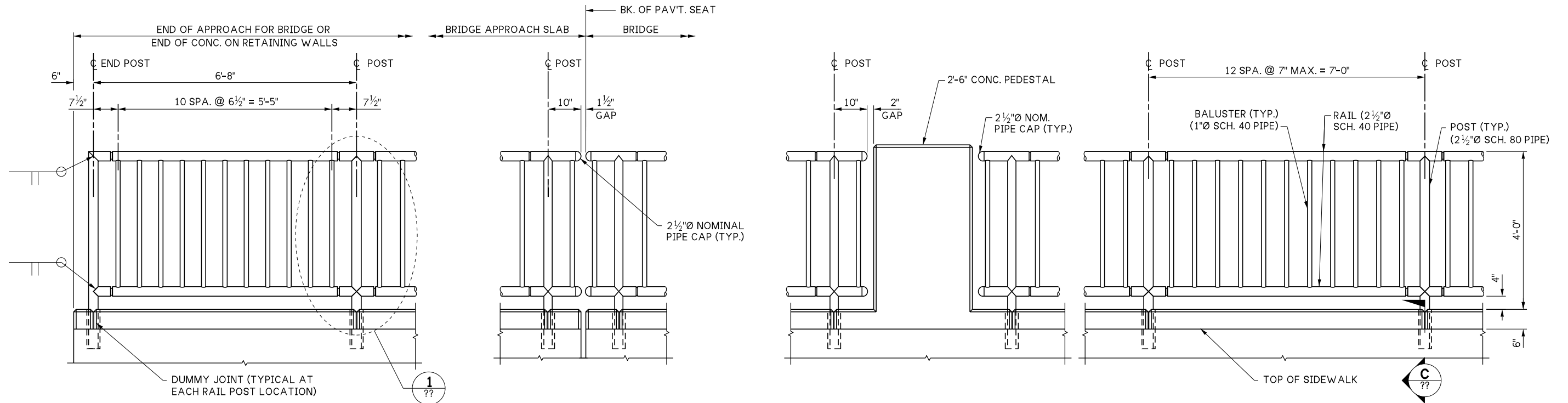

**ELEVATION**

BALUSTERS NORMAL TO GRADE.  
TOP & BOTTOM RAILS PARALLEL TO GRADE.

**GENERAL NOTES:**

- PIPE RAILING AND PIPE RAILING SPLICES SHALL BE BENT TO THE HORIZONTAL CURVE WHERE THE RADIUS OF CURVATURE IS LESS THAN 200'. THESE ITEMS MAY BE HEATED TO NOT MORE THAN 400°F FOR A PERIOD NOT TO EXCEED 30 MINUTES TO FACILITATE FORMING OR BENDING TO HORIZONTAL CURVATURE.
- SHOP DRAWINGS OF RAILING SHALL BE SUBMITTED AS A TYPE 2 WORKING DRAWING SHOWING COMPLETE DIMENSIONS AND DETAILS OF FABRICATION AND INCLUDING AN ERECTION DIAGRAM. MATERIAL SPECIFICATIONS SHALL BE PROVIDED IN THE SHOP DRAWINGS FOR ALL COMPONENTS.
- CUTTING SHALL BE DONE BY SAWING OR MILLING AND ALL CUTS SHALL BE TRUE AND SMOOTH. FLAME CUTTING WILL NOT BE PERMITTED.
- WELDING ALUMINUM SHALL CONFORM TO STD. SPEC. SECTION 9-28.14(3).
- ALL ALUMINUM PARTS SHALL BE GIVEN A \*~~(CLEAR OR BRONZE)~~ ANODIC COATING OF AT LEAST 0.0006" THICK AND SEALED TO MEET THE REQUIREMENTS OF ASTM B 580 WITH A UNIFORM FINISH.
- PIPE RAILING, PIPE BALUSTERS AND PIPE RAILING SPLICES SHALL BE ADEQUATELY WRAPPED TO ENSURE SURFACE PROTECTION DURING HANDLING AND TRANSPORTATION TO THE JOB SITE.

*\* NOTE TO DESIGNER:  
Designer to choose color for their project in consultation with Bridge Architect.*

MAT'L	PART	MATERIAL SPECIFICATION
ALUMINUM	RAILS & BALUSTERS	ASTM B221-6005-T5, 6005A-T5 OR ASTM B241-6061-T6
	STRIP	ASTM B221-6005-T5
STEEL	ANCHOR BOLTS, NUTS & WASHERS	STANDARD SPECIFICATION SECTION 9-06.5(4) GR. 36 (GALVANIZE IN ACCORDANCE WITH AASHTO SPECIFICATION M 232)
	DRIVE PINS	ASTM A276 OR A240 TYPE 302 STAINLESS STEEL

FILE NAME	10.5-A4-1_Pedestrian Railing Details 1 of 2.dgn			
BRIDGE DES. ENG.				
BRIDGE PROJ. ENG.				
SUPERVISOR				
DESIGNED BY				
CHECKED BY				
ENTERED BY				
PRELIM. PLAN BY				
ARCH. / SPEC.				
	REVISION	DATE	BY	

REGION NO.	STATE
10	WASH
JOB NUMBER	
CONTRACT NO.	

**WSDOT**

PRELIMINARY PLAN  
NOT FOR CONSTRUCTION

SEE CERTIFICATION SHEET DATE	SEE CERTIFICATION SHEET DATE
STAMP BOX	STAMP BOX

STANDARD DESIGN DRAWINGS BRIDGE RAILINGS	PLAN REF NO
PEDESTRIAN RAILING DETAILS 1 OF 2	SHEET OF SHEETS

10.5-A4-1