

LAST REVISED: 08/30/2024

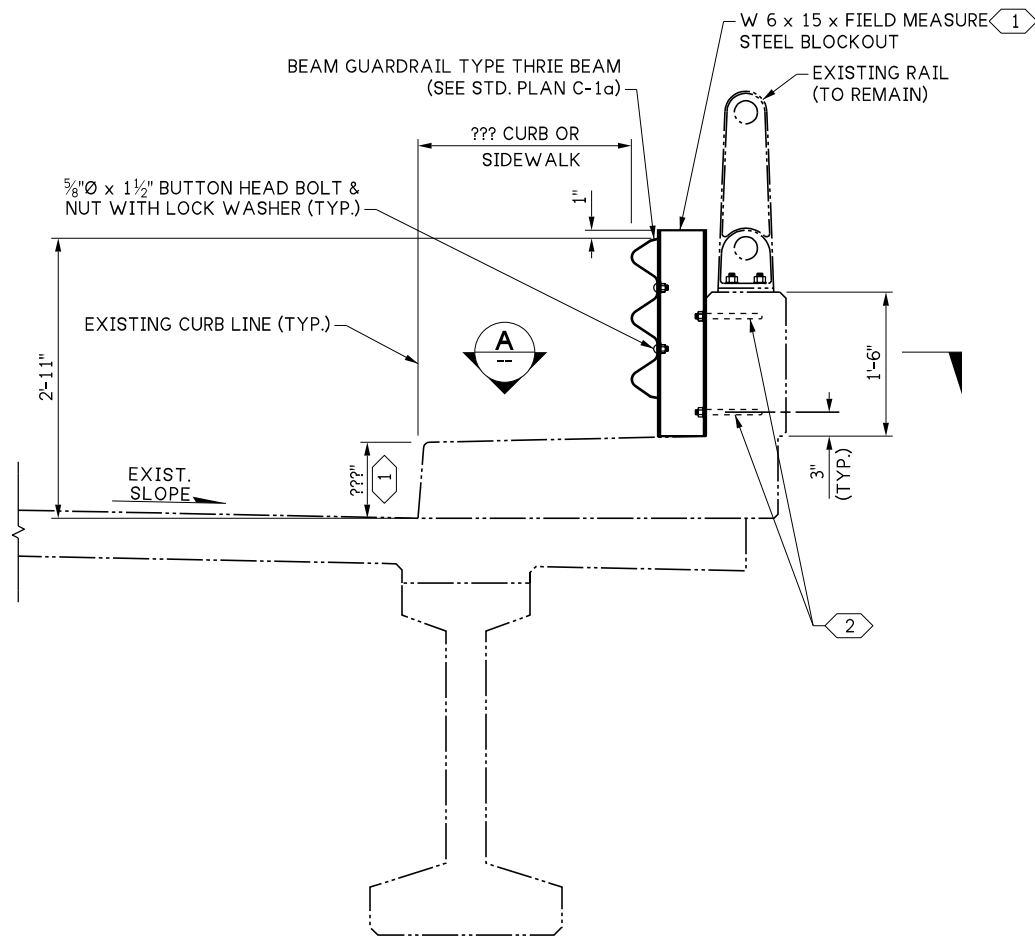

**TYPICAL SECTION AT STEEL BLOCKOUT**  
(???) ASSEMBLIES REQUIRED

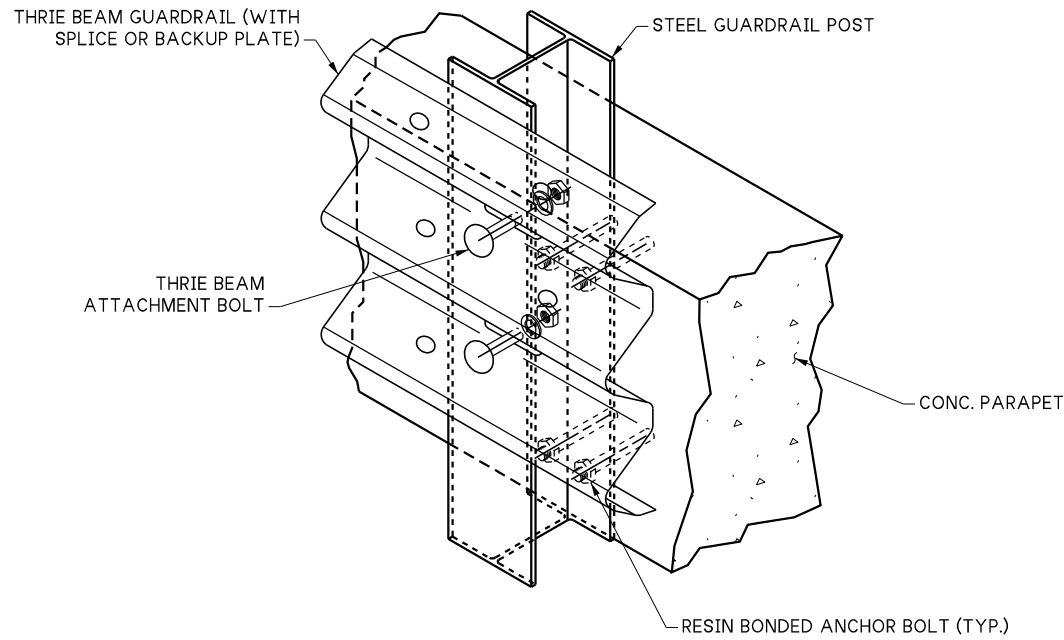

**ISOMETRIC VIEW**

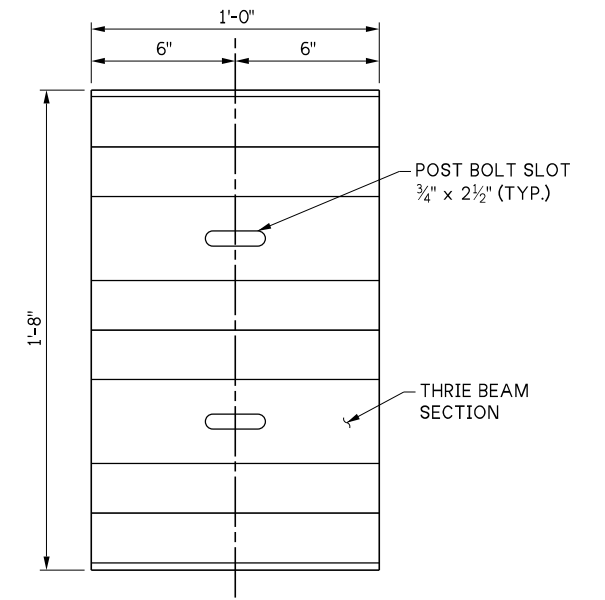

**BACKUP PLATE**  
BACKUP PLATE REQUIRED AT POST WHERE NO THRIE BEAM GUARDRAIL SPLICE OCCURS

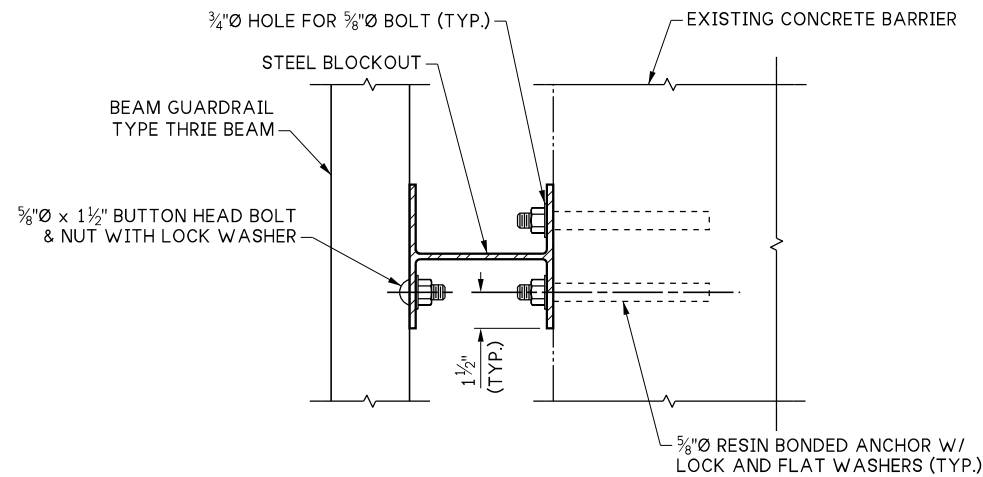

**SECTION A**

**KEY NOTES:**

- 1 SEE GENERAL NOTE NO. 5 ON BRIDGE SHEET NO. 1.
- 2 CORE DRILL HOLES FOR 5/8\"/>

10.4-A 1-2

FILE NAME	10.4-A 1-2_Thrie Beam Retrofit Concrete Railbase.dgn		
BRIDGE DES. ENG.			
BRIDGE PROJ. ENG.			
SUPERVISOR			
DESIGNED BY			
CHECKED BY			
ENTERED BY			
PRELIM. PLAN BY			
ARCH. / SPEC.			
	REVISION	DATE	BY

REGION NO.	STATE
10	WASH
JOB NUMBER	
CONTRACT NO.	

**WSDOT**

PRELIMINARY PLAN  
NOT FOR CONSTRUCTION

SEE CERTIFICATION SHEET DATE	SEE CERTIFICATION SHEET DATE
STAMP BOX	STAMP BOX

STANDARD DESIGN DRAWINGS RAIL RETROFITS
THRIE BEAM RETROFIT CONCRETE RAILBASE

PLAN REF NO
SHEET OF SHEETS