

WST2

Washington State Technology Transfer

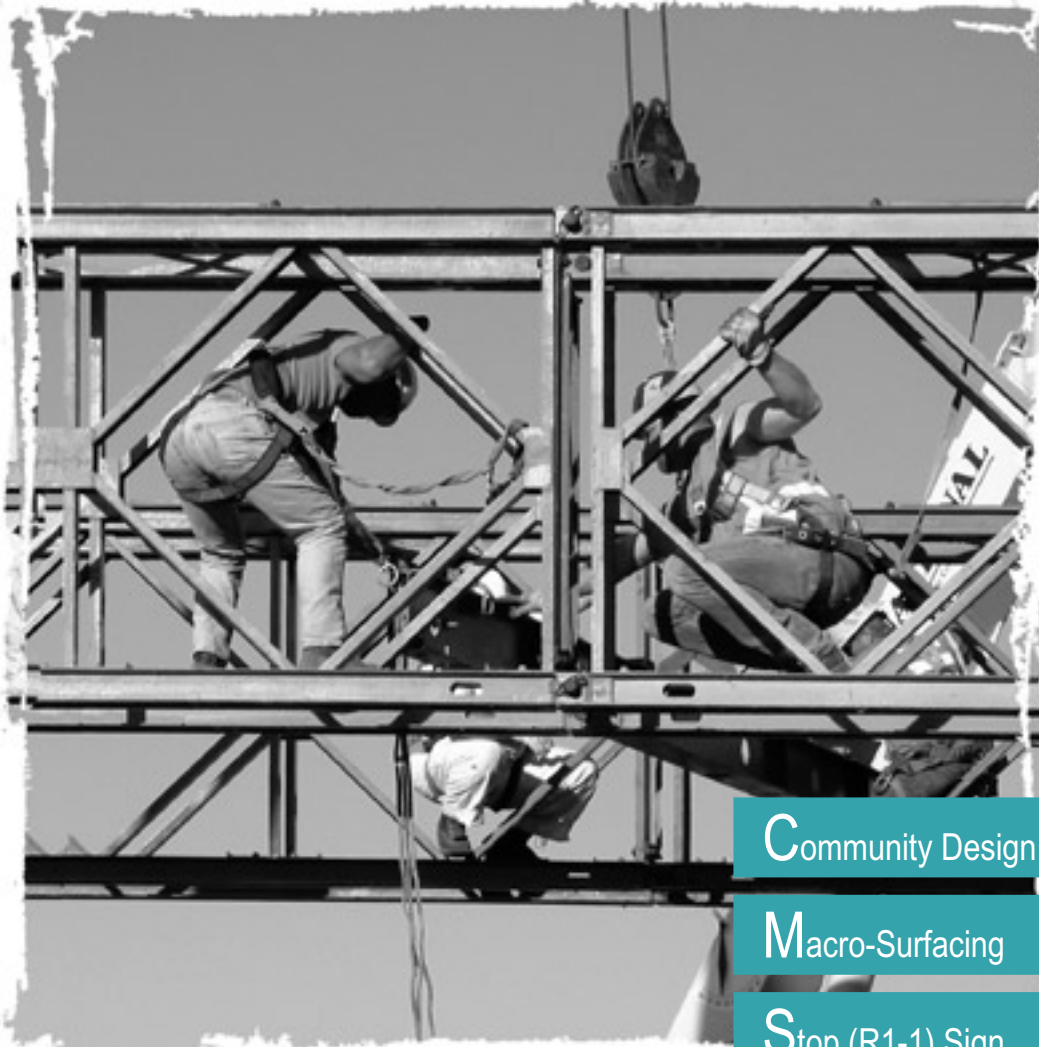

Community Design Team pg 12

Macro-Surfacing pg 9

Stop (R1-1) Sign pg 19



**Washington State
Department of Transportation**

A Technical Digest of
the Washington State Department of Transportation
(WSDOT) and the Local Technical Assistance Program
(LTAP)

Issue 76, Fall 2002

WST2 Washington State Technology Transfer

is published quarterly without fee in
February, May, August, and November

by WSDOT Highways & Local Programs
Washington State Technology Transfer Center
310 Maple Park Ave. SE
PO Box 47390
Olympia, WA 98504-7390

e-mail: wst2center@wsdot.wa.gov
Home Page: www.wsdot.wa.gov/TA/T2Center/T2hp.htm

Requests for subscriptions, change of address, and other subscriber services should be addressed to SchmidW@wsdot.wa.gov, or phone (360) 705-7386, or WST2 Center, PO Box 47390, Olympia, WA 98504-7390. Subscriptions are served free of charge.

Issue 76, Fall 2002

POSTMASTER:
Please send address changes to WST2,
P.O. Box 47390, Olympia WA 98504-7390

Include both old label and new address.



Article contributions, questions, or comments are welcome. Please contact the editor, Dan Sunde, P.E., WST2 Center, PO Box 47390, Olympia, WA 98504-7390; phone (360) 705-7390, fax (360) 705-6858, or e-mail SundeD@wsdot.wa.gov.

Editor reserves the right to refuse to publish and to edit articles to conform to the standards of our publication.

The opinions expressed in articles are not necessarily those of the editor.

Cover Photo: WSDOT bridge crew assembles the WSDOT Emergency Bailey Bridge as a training exercise and demonstration at the 2002 Pacific Northwest Transportation Technology Expo.

F rom the Editor's Desk	3	P QT News	30
T echnology News	4	2002 Awards of Excellence Winners	30
ArcIMS for Local Governments	4	Steamboat Slough Bridge Project Activities Alleviate Traffic Impacts Demonstrating Quality Construction	32
FHWA Develops New Intersection Safety Toolkit	6	Successful Partnerships for US 12 Phased Projects	34
Technology Transfer Center CD Library	7	N WPMA News	35
WSDOT Adds Technical Errata to Design Policy Web Page	7	Words from the Chair	35
WSDOT Unveils New Website for Context Sensitive Solutions	8	U SDOT FHWA/NHTSA	36
Technology Infobit - The Internet	8	IntersectionSafety Facts	36
A rticles	9	Making Work Zones Work for You	37
RoadArmor® Macro-Surfacing Another Tool for the Pavement Manager's Toolbox	9	New NHTSA Study Shows Economic Impact of U.S. Motor Vehicle Crashes Reaches \$230.6 Billion	39
"CLICK IT OR TICKET" Just May be the Fix-it	11	W SDOT Library	40
The Community Design Team-A Tool for Creating Livable Communities	12	R oger's Technology Toolbox 2002	41
Iowa's Low-Cost Strategy for Delineating Utility Poles	16	Global Positioning System (GPS) Offset Devices: More Tools for the Toolbox	41
LTAP Centers Bring Resources to Local Agencies	17	W ST2 Resources	46
The STOP (R1-1) Sign and Supplemental Devices	18	T rainning Opportunities	48
WSDOT Uses Context Sensitive Solutions to Get the Job Done!	20	C onferences	52
WST2 List Serves - Improved Communications At Lower Cost	21	S ign of the times	52
M ousetraps	24		
GuardrailPost Screw	24		
Steve Potter and Mike Albright's Mobile Work Zone Traffic Control (WZTC) Cone and Sign Storage	26		

CD Library \$10

**2 full years of manuals
updated every 6 months**

WSDOT Engineering Publications

50+ Manuals

Standard WSDOT forms

Access to WSDOT and LAG "intelligent" forms

Runs on Macintosh, Win 95, Win NT & Win 3.x

Contact Stephanie Williams,

WSDOT Engineering

WilliSr@wsdot.wa.gov

(360) 705-7430



From the Editor's Desk



Dan Sunde
Technology Transfer Engineer
WST2 Center

The WST2 Center has been busy these past few months with our partnerships with the WSDOT Highway Maintenance Office and FHWA to put on our third Pacific Northwest Transportation Technology Expo in Moses Lake. The Center has participated in several other conferences including the Road and Street Maintenance-East Conference.

The WST2 Training Program is progressing well so far this year with the number of classes offered by the Center approaching a record 100 classes for the year.

In late July, I had the opportunity to attend the National Local Technical Assistance Program (LTAP) Conference in Burlington, Vermont. This is the annual gathering of all the Technology Transfer Centers in the country. During the annual awards ceremony, the WST2 Center was recognized by the National LTAP Association as one of three outstanding Technology Transfer Centers in the country. The Center was recognized for its innovation and services. Particular mention was made about the quality of our "newsletter", the WST2.

We extend that honor to our Advisory Committee, the Graphic Communications staff and to each author who has participated in the WST2 Center and in the WST2 newsletter by passing on their knowledge and expertise through articles and information. You're a major reason for the success.

Over this last quarter, the WST2 Center said farewell to another T2 Advisory Committee member. After eight years of serving on the WST2 Advisory Committee, Will Kinne, Pierce County Maintenance Manager, resigned from the Committee with his well-deserved retirement from Pierce County. Will has been an outstanding asset to the LTAP with his innovative, practical thinking. We appreciate all the support and input he has provided over the years. Will, we wish you the best in your retirement! Thanks.

Secretary of Transportation
Douglas B. MacDonald

Chief of Staff
Paula Hammond, P.E.

Director of Highways & Local Programs
Kathleen Davis

Technology Transfer Engineer & Managing Editor
Dan Sunde, P.E.

Publishing Editor
Kimberly Colburn

Assistant Editor
Wendy Schmidt

Graphic Design
Jennie Throckmorton

Staff Writers
Bob Brooks
Roger Chappell
Laurel Gray
Dave Sorensen

The Local Technical Assistance Program (LTAP) is a national program financed by the Federal Highway Administration (FHWA) and individual state transportation departments. Administered through Technology Transfer (T2) Centers in each state, LTAP bridges the gap between research and practice by translating state-of-the-art technology into practical application for use by local agency transportation personnel.

Any opinions, findings, conclusions or recommendations presented in this newsletter are those of the authors and do not necessarily reflect the views of WSDOT or FHWA. All references to proprietary items in this publication are not endorsements of any company or product.

 Washington State
Department of Transportation

 U. S. Department of Transportation
Federal Highway Administration

ArcIMS for Local Governments

Naomi W. Marshall, Technical Writer,
Marshall and Associates, Inc.

There's no denying it; the power of visualization produces great effects and the power of interaction produces even more. So, when you offer an interactive mapping application over the Internet, the effects and benefits are immeasurable.

ESRI's (Environmental Systems Research Institute, Inc.) ArcIMS offers such an application. ArcIMS, an Internet mapping solution, has provided a foundation for disseminating high-end GIS, database, imagery, and other data sources via the Internet/Intranet.

Many local governments are recognizing the ease, efficiency, and time/cost savings that ArcIMS software offers.

ArcIMS Key Capabilities:

- Integrates local data sets, GIS, and other databases, such as the Hansen database
- Users only need a browser
- Customizable
- Open and interoperable environment
- Standard-based communication (arcXML - extension to XML)
- Multitier architecture
- Highly scalable architecture

Many local governments are recognizing the ease, efficiency, and time/cost savings that ArcIMS software offers.

Though an out-of-the-box ESRI product, business partner Marshall and Associates, Inc. (Marshall) has been developing and customizing ArcIMS applications for local governments since 1999.

Marshall ArcIMS Lead, Rhett Harman, describes the ArcIMS development process: "When developing an ArcIMS application, we first meet with our customer to plan the project and coordinate project details. The next step is to work with the customer to document all of their needs, requirements, and specifications; this assures that no details fall through the cracks."

Based on these requirements and specifications, Marshall develops a conceptual design, reviews this design with their customer, and creates a detailed design and implementation plan. Expert programmers develop the application

before putting it through extensive testing. It is reviewed on Marshall's server and finally deployed at the customer's designated site.

Using a similar process, Marshall developed an interactive web application for the city of Albany, Oregon to serve their GIS data over the Internet. This application hits a variety of databases using Active Server Pages (using the Active X Connector of ArcIMS). Users can type in a street address or property owner's name and the application will zoom-in to a view of that particular piece of property. Users can view general and planning information regarding the property and print application information.



For this project, Marshall developed custom work-arounds to significantly improve access to a large number of GIS layers. This solution was unique and greatly improved the application's performance. Prior to this development, other application developers had not yet addressed this particular problem.

"When developing an ArcIMS application, we first meet with our customer to plan the project and coordinate project details. The next step is to work with the customer to document all of their needs, requirements, and specifications; this assures that no details fall through the cracks."

With their ArcIMS application deployed, the city of Albany reported a significant reduction in the amount of time it took City staff to respond to walk-in requests for map products and information. Outside users, such as realtors, appraisers, and developers, realized a significant cost savings by not having to send their staff to City Hall to conduct research.

One such user commented, "This is an amazingly powerful and flexible website, given the nature of the

information layers under the user's control... This office performs commercial property appraisals, and for our jobs in Albany, this Website is a vital tool. I wish this tool were available for every community in Oregon; it would make my job immeasurably easier."

The City also reported such benefits as reduced internal software deployment costs (since no additional licenses were required) and the number of phone inquiries that the City staff fields has decreased and continues to decrease as more and more citizens are made aware of the site.

As Albany user testimonies illustrate, Web-mapping is rapidly becoming the standard for deploying local government information and ArcIMS is leading the way. And with its speed, intuitive nature, easy-to-use capability, and overall cost-savings... it makes sense. ▲



FHWA Develops New Intersection Safety Toolkit

FHWA has developed a communications toolkit containing a series of briefing sheets on intersection safety-related topics. The topics include:

- The National Intersection Safety Problem
- Basic Countermeasures to Make Intersections Safer
- Pedestrian Safety at Intersections
- Human-factors Issues in Intersection Safety
- Intersection Safety Enforcement
- Traffic Control Devices: Uses and Misuses
- Red-Light Running Issues
- Red-light Cameras
- Workzone Intersection Safety
- Intersection Safety: Myths versus Reality
- Intersection Safety Resources

The purpose of the toolkit is to enhance communications with the media, decision-makers, the general public, and others about intersection safety. The goal is to provide this information to the widest audience possible within the education, law enforcement, and engineering communities and to the general public. The toolkit was developed by the Midwestern Resource Center (Pat Hasson and Fred Ranck).

To receive a toolkit, please contact Pat Hasson at (708) 283-3595. The briefing sheets will soon be available on the Intersection Safety website at <http://safety.fhwa.dot.gov/programs/intersections.htm>.

FHWA Finalize National Intersection Safety Agenda

FHWA, with its partners, has finalized a comprehensive national intersection safety agenda. The agenda was developed at the national intersection safety workshop held in Milwaukee, WI on November 14 - 16, 2001. Also, as a part of the overall effort to enhance intersection safety awareness, FHWA has developed a video, Red Light Green Light. The purpose of the video is to take a closer look at intersection safety and emphasize the importance of individual responsibility when it comes to making intersections safer.

Contact Hari Kalla (202-366-5915) for more information or visit the new intersection safety web site at <http://safety.fhwa.dot.gov/programs/intersections.htm>

Technology Transfer Center CD Library



Bob Brooks, WST2 Pavement Technology Engineer

The WST2 Center is now packaging technical manuals, technical documents, and past issues of the WST2 Newsletter into a CD-based library for distribution. This is a great way to receive the technical material you want. Literally dozens of documents can be packed onto one CD and they take up very little room in your office.

In addition, the CD is updated on a periodic basis and announcements are sent to the pavement list serve subscribers when these updates are made available. This allows you



to review the contents of the new library and order a copy only if you wish to receive any of the new material included on the updated edition. Ordering is as easy as sending your mailing address in response to the list serve announcement and the CD will be sent right to your office. Besides being convenient for our customers, this approach helps us keep our printing and mailing costs down without having to sacrifice customer service.

So if you're not already a subscriber to the pavement list serve, please think about signing up. See the list serve article in this newsletter for more information. ▲

WSDOT Adds Technical Errata to Design Policy Web Page

Bill Stoll, WSDOT Headquarters Design Office

A new feature has been added to the Design Policy Web Page. It is an up-to-date technical errata sheet listing all known technical errata through the latest Design Manual revision (February 2002).

Technical errata in this case generally mean an incorrect value, incorrect reference or missing or incorrect word. It is recognized that there are still some misspelled words and organizational names that need to be changed but they do not have an immediate effect on design guidance provided. No policy changes are affected as a result of these errata.

You can access this new feature at: <http://www.wsdot.wa.gov/eesc/design/policy/designpolicy.htm>

These errata are not found in all versions of the Design Manual. A note to this effect will be added to the web page. It is expected that this errata page will be a dynamic document and will be updated as often as necessary.

If you know of or find any additional errata that should be included on this list and in a subsequent Design Manual revision, please send them on the Comment Form, which is found in the Design Manual, to the HQ Design Policy office or send e-mail to designmanual@wsdot.wa.gov. ▲

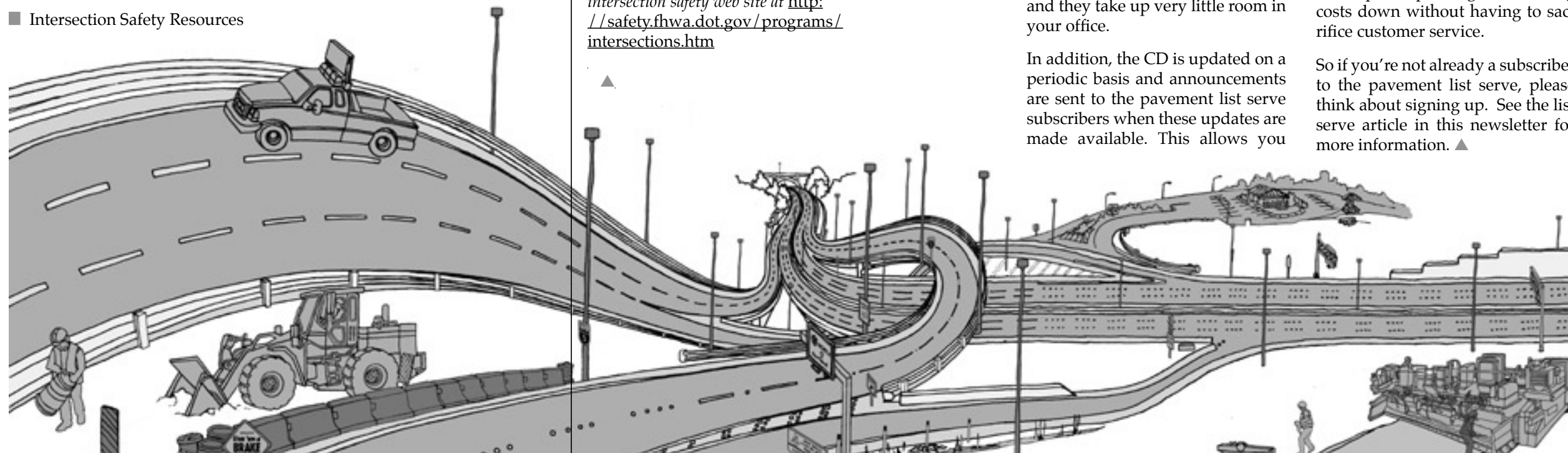

WSDOT Unveils New Website for Context Sensitive Solutions

Julie Mercer Matlick, WSDOT
H&LP Urban Partnerships Program
Manager

Following the huge success of the Safety, Aesthetics, and Community Partnerships: Context Sensitive Solutions regional workshop, which was held on April 30-May 1, 2002, WSDOT's Highways & Local Programs (H&LP) unveiled a new website for both local agencies and WSDOT to enable staff to find more information on the topic. Context Sensitive Solutions (also termed Context Sensitive Design-CSD) are shared, interdisciplinary techniques that involve all partners to develop a transportation facility that fits its physical surroundings and preserves scenic, aesthetic, historic, and environmental resources, while maintaining safety and mobility. Currently the website fea-



tures an overview of the workshop as well as the CSD-Symposium "Main Street America Meets Main Street Europe" which was held May 2-3, 2002. Of special interest is the Workshop and Symposium proceedings, which feature exem-

plary examples of true "community partnership" projects and best practices.

The website can be found at <http://www.wsdot.wa.gov/biz/csd>.



Technology Infobit - The Internet

Courtesy of William C. Evans, LTAP Manager, USDOT-FHWA

"San Francisco is the U.S. city with the highest Internet household penetration, at 66%, followed by Seattle with 64% and San Diego with 62%. Washington D.C. ranks fifth with 59%."

- U.S. Department of Commerce

"All high schools in Denmark have Internet access, and 95% of schools in Sweden. In contrast, only 23% of Italian schools are connected to the Internet."

- European Commission

"Each month Yahoo hosts a billion minutes of Internet phone calls, ships 6.1 billion messages and emails, and runs 15 million hours of audio and video"

- FORBES

"Original Ideas:

Internet 0

Humanity 1,000,000,000,000,000

- Peoplesoft.com

RoadArmor®

Macro-Surfacing Another Tool for the Pavement Manager's Toolbox



RoadArmor machine applying emulsion and cover rock.

Bob Brooks, WST2 Pavement
Technology Engineer

On August 13, 2002 Koch Pavement Solutions sponsored a demonstration in Gig Harbor, WA of RoadArmor Macro-Surfacing, their proprietary and improved version of the chipsealing process. Like any seal coating process, RoadArmor is a preventive maintenance treatment that is suitable for roads in reasonably good condition having only minor surface distresses. Good surface preparation is also a must for a quality product. The

The polymer-modified emulsion has been formulated for a fast chemical break that is less dependent on atmospheric conditions than a traditional emulsion.

surface should be swept and cracks sealed prior to applying any seal coat including RoadArmor.

The RoadArmor Macro-Surfacing system is comprised of four elements: a fast setting polymer modified emulsion; single-sized high quality aggregate; an application process that uses one machine to apply both emulsion and aggregate in a single pass; and performance-related specifications to ensure material compatibility and reliable performance. Material compatibility and performance are determined



Live bottom truck supplying rock and emulsion.

by a sweep test of a laboratory prepared sample to determine the amount of material loss.

The polymer-modified emulsion has been formulated for a fast chemical break that is less dependent on atmospheric conditions than a traditional emulsion. This allows for very aggressive chip adhesion with less chip loss and a quick return to traffic. The emulsion can be adjusted for individual climate conditions and with the aggressive chip adhesion there is less risk of vehicle damage from loose rock. Testing requirements of the base asphalt used in the emulsion include penetration and elastic recovery.

As with any chipseal, the aggregate must be clean to ensure a proper bond with the emulsion. The aggregate used with RoadArmor is a single-sized gradation that allows a thicker membrane to be applied (.43 - .45 gal/sq. yd. is typical) and provides for better aggregate adhesion. The single sized rock also allows better draining of water and provides a quieter ride than a more typical gradation. Included in the specifications for RoadArmor aggregates are requirements for gradation, fracture, flakiness, cleanliness, and hardness.

The most unusual departure for

RoadArmor is the application process used, a single-pass machine that shoots the emulsion and then immediately applies the aggregate cover. The computer controlled machine has a continuously adjustable spray bar and chip spreader up to 18 feet in length. Typical application speeds range from 250 to 350 ft/min and the machine is fed from the front by special 20-yard live bottom trucks that also carry a 1,000-gallon tank to replenish the emulsion. This means that no supply trucks travel on the newly laid seal and as long as sufficient trucks are used the process can operate non-stop. The paving machine is followed closely by a sufficient number of pneumatic tired rollers that make a minimum of three passes. Sweeping, using sufficient sweepers for three passes, is normally performed within an hour of application and once swept the road can then be returned to traffic. During the interim before sweeping and after rolling, traffic should be kept below 25 miles per hour on the new seal.

Given the improved performance and quick return to traffic, the RoadArmor process can be a good addition to the pavement manager's toolbox. Now what everyone wants to know is, what is the cost? At the present time, RoadArmor

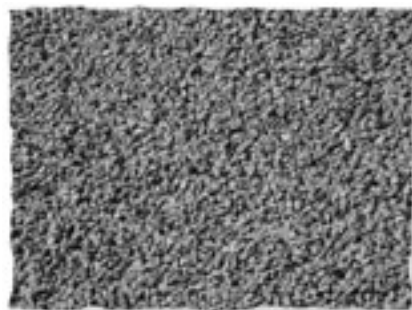

The newly applied RoadArmor seal.

Macro-Surfacing costs about \$1.65 per square yard. While more expensive than a typical chipseal, this is still well within the acceptable range for a preventive maintenance treatment and offers many advantages to the pavement manager.

"CLICK IT OR TICKET" Just May be the Fix-it

WTSC Traffic Research & Data Center, Data Note June 2002

The Washington State "Click it or Ticket" project was implemented in early May 2002 and was intended to increase the seat belt use rate. The project involved media messages to inform the public that seat belts save lives and that police agencies will be enforcing the seat belt law. A major traffic enforcement effort targeting non-use of belts was undertaken during a two-week period around Memorial Day, May 20 to June 2.

Evaluation of the project consisted of observation surveys of belt use by drivers and front seat passengers. Five mini-surveys were conducted covering the pre-project phase, media phase, enforcement phase, and the post-enforcement phase. The survey dates and project phases are shown in the table at the top right.

The surveys were conducted in five counties and included 40 roadway sites, eight sites per county. The sites were a convenience sample that included a cross-section of highways/interstates and local roads (city streets and county roads). Observers counted shoulder belt use or non-use during 40-minute data collection periods at each site.

Results of the surveys are shown in the table at the right. Seat belt use rates were consistent at about 80-81 percent for the baseline and media phases of the project. For

comparison, the use rate at the same 40 sites in the 2001 survey was 81.4%. During the enforcement phase the belt use rate increased to

88.5% and remained high at 89.5% in the post-enforcement phase. Results for each of the counties in the mini-surveys are shown below.

WASHINGTON STATE

CLICK IT OR TICKET OBSERVATION SURVEYS OF SEAT BELT USE

SURVEY #	DATE	PROJECT PHASE	SEAT BELT USE RATE
1	APRIL 25	BASELINE	80.8%
2	MAY 9	EARNED MEDIA	80.4%
3	MAY 16	PAID MEDIA	81.3%
4	MAY 30	ENFORCEMENT	88.5%
5	JUNE 6	POST-ENFORCEMENT	89.5%

Seatbelt Usage by Month (in %)

COUNTY	4/25/02	5/9/02	5/16/02	5/30/02	6/6/02
Mason	85.2%	87.1%	87.0%	94.5%	93.2%
Pierce	83.3%	82.3%	84.1%	89.3%	90.2%
Spokane	81.3%	81.2%	80.5%	87.5%	89.5%
Walla Walla	77.3%	72.1%	75.8%	87.1%	89.2%
Yakima	67.6%	66.0%	69.4%	79.4%	82.9%
Overall Usage	80.8%	80.4%	81.3%	88.5%	89.5%
Baseline					

THE COMMUNITY DESIGN TEAM-A TOOL FOR CREATING LIVABLE COMMUNITIES



By Ronald W. Eck, P.E., Michael R. Blankenship, P.E., and William D. Wyant

Throughout the United States, small communities face concerns about quality of life issues. People want their communities to be functional and vibrant places to live and work. Although specific community needs may vary widely, usually the principal issues are people, neighborhoods, and business (e.g., economic development and vacant downtown buildings).

Typical transportation-related local concerns include streets that lack character and need improvement, landscaping and street furniture, parking and truck traffic (1). The challenge facing small communities is to come to grips with these issues in a systematic manner and develop a viable vision for the future.

The same scenario faces many small rural communities in West Virginia where coal mining, oil and gas production, and timbering operations have declined altogether. Not only has the population shrunk, it has become older as young people move away to pursue career opportunities that do not

exist in the community. Local leaders and concerned residents look for attributes that will help retain the young people, attract tourists or enhance economic development while retaining the quality of life. Unfortunately, most communities lack the financial and human resources to undertake a formal assessment of steps that will help prepare for a promising future.

West Virginia University has developed and made available a resource to assist with this process. The Community Design Team (CDT) is a multi-disciplinary group of volunteer professionals who have skills that are helping West Virginia communities plan for their future. The team accomplishes this through a dynamic and interactive process that brings a broad base of community members together with design and development professionals. The CDT process is fast-paced with work sessions that fully involve the community in identifying important issues. The results are identified issues and recommendations on how the community might tackle them.

The CDT Process

The West Virginia CDT program made its first community "visit" in May 1997. Originally coordinated through the Extension Service at West Virginia University (WVU), currently, it is based in the Department of Landscape Architecture in the Division of Resource Management at WVU.

Smaller towns and cities in West Virginia are eligible for CDT visits. Communities wishing to receive a visit from a team complete an application form to identify basic facts and figures used to gauge the level of community involvement. Applications are evaluated based on need, evidence of broad-based community involvement and anticipated objectives of the visit. Communities then receive a screening visit from members of the

CDT steering committee before a final decision is made on a CDT visit. Once a visit is scheduled, the CDT team leader coordinates with community representatives to facilitate visit logistics, including host families, meeting space, meals, local site visits, and presentations from community organizations and leaders.

The CDT Team

The CDT is a group of volunteer professionals who have skills that can help communities plan for their future.

A typical team might include architects, planners, civil engineers, traffic engineers, historians, landscape architects, public administration and economic development experts, natural resource specialists, and health care professionals. Team selection is based on the needs expressed by the community and the availability of volunteers. While the CDT is based at WVU, the group relies on volunteers from a variety of public and private organizations to complete its mission. Team

members on recent visits have included University faculty and staff, extension specialists, physicians and health promotion specialists, representatives of state and federal agencies, businesspersons, and even a state senator.

One benefit of being located at a university is the availability of students who participate as team members. In addition to the "real-world" experiences the students obtain from participating in a visit, the community also benefits from the conceptual drawings and graphics that the students generate during the visit.

A Typical Visit

A typical CDT visit lasts from Thursday evening to Saturday evening. On Thursday, CDT members meet their community host families. The host families reduce the costs of the program and help team members get acquainted with the community.

A key part of the program is the information the community

provides to the team about itself, so the team uses most of Friday to listen to the community. The community identifies several key local people who make formal presentations to the CDT about the community's strengths, weaknesses, opportunities, and threats. These presentations are made by a broad cross-section of the community leaders, including education, health care, economic development, senior citizens, local government, chamber of commerce, and service organizations. Prior to the visit, the youth of the community are given disposable cameras and are sent out to photograph the community. On Friday, they present insightful views of "the good, the bad, and the ugly" of the community. These are often the most informative presentations, since the youth are very honest and "non-political." Also on Friday, there are "walkabouts"

Typical transportation-related local concerns include streets that lack character and need improvement, landscaping and street furniture, parking and truck traffic.

and "drive-throughs" to help CDT members become familiar with the physical dimensions and infrastructure of the community and surrounding area.

On Friday evening, there is an open community meeting where the CDT is introduced to the community at-large. Through structured exercises, developed specifically for the community based on what the team learned earlier in the day, citizens have an opportunity to express their opinions about community strengths and needs and their visions of the future.

From Friday night until late Saturday afternoon, team members work intensively and interactively to develop a set of recommendations that address the needs expressed by the community. These are presented via "flip chart" panels consisting of bulleted lists and supporting graphics.

For the volunteer professionals, these work sessions are usually the most stimulating and challenging part of the visit. The "design" process is a dynamic and interactive one, which typically does not unfold in an orderly, straight-line fashion that neatly converges on

solutions. The process is frequently iterative and subject to shifts and refinements as it moves toward a conclusion (the presentation deadline). The most important questions that arise during the process are not usually matters of expertise. The challenge is to identify the values and priorities of the community and to decide which recommendations/approaches are legitimate and which are not.

A second open community meeting is held on Saturday evening where team members make a formal 60- to 90-minute presentation of findings and recommendations. An effort is made to present three categories of recommendations:

1. those that can be accomplished immediately,
2. those that can be accomplished in 6 to 12 months, and
3. those that can be accomplished in one year or more.

This session also provides an opportunity for community members to ask questions and to provide feedback.

About 6 weeks after the visit, the community receives 40 copies of the recommendations report that consists of 8 1/2 x 11 color versions of the flip chart panels and a transcript of the formal presentation. These reports are used in prioritizing the community's action plans, and they have also been used in writing grant proposals.

Approximately 6 months after the CDT visit, a small group of CDT members returns to the community to meet with citizen action groups and others interested in maintaining the momentum generated during the CDT visit. It is an opportunity for the CDT to lend additional insight, to refer the community to other resources and to act as a sounding board for community endeavors or ideas that have surfaced since the original visit.

Community Involvement is Key to Success

Although the team is comprised of professionals and students who donate about \$20,000 in professional services per community visited, there are some out-of-pocket costs. These include photographic services, team member travel, mailings, drawing/art materials, and copying. Therefore, each community pays \$3,000 to cover these costs in addition to the lodging with host families and meals. This financial involvement by the community also assures a “buy-in” from the community, leading to greater participation before, during, and after the visit.

Prior to the CDT visit, the local community coordinator has many responsibilities. These include:

- Provide base maps and aerial photos of the city and region.
- Provide planning studies/master plans, economic development data, etc.
- Get the word out: newspaper and radio spots to stimulate community involvement.
- Recruit host families.
- Coordinate Friday/Saturday public meetings, usually involving potluck dinners.
- Coordinate Friday/Saturday lunches for team (breakfast is generally with host family).
- Recruit speakers for Friday presentations.
- Arrange meeting space for CDT activities.
- Arrange transportation and narrators for tours of the area.

Including local “champions” in the Friday and Saturday sessions is a key factor in the successful implementation of many of the CDT’s recommendations.

A typical team might include architects, planners, civil engineers, traffic engineers, historians, landscape architects, public administration and economic development experts, natural resource specialists, and health care professionals.

The local community coordinator should identify these people who can carry forward and implement ideas, and make sure they are available during the visit. After the visit, the champions can work with key team members as they begin to coordinate citizen action groups to implement team recommendations.

Since the program’s inception, 15 CDT visits have been made to West Virginia communities. As would be expected, community issues and needs have varied widely and have included, for example, economic development, leadership and capacity-building, and health care. Transportation-related issues have been a major concern on all visits. Typically, they include parking, traffic flow and creating a pedestrian-friendly environment. This section discusses several communities where transportation issues were prominent and where, as transportation professionals, the authors made follow-up visits to examine

specific transportation problems in greater detail.

Maintaining the Momentum

During the CDT visit, there is usually considerable interest and enthusiasm about the community’s future. Unfortunately, in some cases, this enthusiasm and momentum dissipate after the visit and recommendations are not pursued. In the authors’ opinions, this is typically not due to the lack of interest or good intentions but rather due to the lack of local level experience in organizing and facilitating community groups. Thus, a key component of each visit should be formal treatment of community capacity building. The WVU Extension Service offers specific programs in this area. It would be desirable to explore a more formal linkage between this program and the CDT program to ensure that capacity-building expertise is part of each visit.

Another key factor in maintaining momentum is the breadth of community involvement prior to and during the CDT visit. There is a direct relationship between the level of community support and the success of the visit. Representatives from business, health care, schools, neighborhood organizations, senior citizen groups, the municipality and travel and tourism related organizations, and others, desirably, should all be actively involved in the process. Experience has shown that the business community must be an integral part of the CDT process. For example, in one case, proposed sidewalks and other streetscape enhancements stimulated local businesses to improve their properties, which helped to maintain momentum after the CDT visit.

CDT and Context Sensitive Design

The purpose of the CDT is to help communities improve the physical and environmental design of their

communities and address local issues successfully through a process that includes broad-based community support and participation along with professional design and development assistance (2).

The local community coordinator should identify these people who can carry forward and implement ideas, and make sure they are available during the visit.

Context Sensitive Design (CSD)—the art of creating public works projects that are well accepted by both the users and the neighboring communities—also uses a collaborative, interdisciplinary approach that includes early involvement of key stakeholders to ensure, for example, that transportation projects are not only moving people and goods more efficiently, but also are in harmony with the natural, social, economic and cultural environment (3). CSD integrates projects into the community context or setting in a sensitive manner through careful planning, consideration of different perspectives, and tailoring designs to particular project circumstances. In transportation project development, CSD is intended to create excellence by incorporating design standards and flexibility, safety, aesthetics, environmental stewardship, and community sensitivity.

The setting and character of the area, the values of the community, the needs of the highway users, and the challenges and opportunities

are unique factors that designers must consider with each project. For each project, designers are faced with the task of balancing the need for the highway improvement with the need to safely integrate the design into the surrounding natural and human environments. Having a process that is open, including public involvement and fostering creative thinking, is an essential part of achieving good design. Designers are helped along the path to sensitively designed highways and streets by approaches that fully consider aesthetic, historic, and scenic values, along with safety and mobility.

Three underlying principles of CSD—involvement of the public and affected agencies, use of an interdisciplinary team, and incorporation of aesthetics—coincide directly with the processes of CDTs that include broad-based community involvement and multidisciplinary professional design and development assistance. Community members play an important role in identifying local and regional problems and solutions that may better meet the needs of all stakeholders. The selection of CDT members is based in part on the needs expressed by the community in its application and during the team leader’s pre-visit, and one of the two full days during a CDT visit is devoted to acquiring input from community members and organizations. Context Sensitive Design involves the community and brings together interdisciplinary teams—landscape architects, engineers and other disciplines—to find the best design solutions for the context.

The interdisciplinary approach by CDTs brings the design standards of architects, engineers, and landscape architects together with the principles and processes of planners, historians, community and economic development professionals, and others to focus on the needs of the community within its

context.

Both CDT and CSD are multidisciplinary, context-sensitive, and inclusive of public interests. They are intended to take into account many perspectives and find balanced, creative solutions while meeting appropriate design standards and cost and efficiency objectives. They differ significantly in application: CDT visits are brief and rely on the ability of the teams to quickly size-up the situation and come up with immediate, intermediate and long-term recommendations. CSD is a longer, more deliberate and technical process that expects to achieve efficient project delivery in part through the avoidance of expensive and time-consuming rework. Both, however, share approaches encouraging public participation and leading to projects that meet the needs of users, the neighboring communities, and the environment.

Conclusion

Experiences in over one dozen West Virginia communities demonstrate that the Community Design Team process can have a positive impact on helping small communities plan their future and enhance their livability. The degree of success depends heavily on the breadth of stakeholder involvement in the process. Communities with active involvement from a broad cross-section of the community are more likely to be successful in the process and particularly in maintaining the interest and enthusiasm so critical to implementation after the CDT team leaves.

Because it makes use of volunteers, the CDT approach is an affordable process for most communities. In the visits to date, there has been no difficulty in getting the participation of diverse groups of volunteer professionals. The current “visitation” rate of 3 to 4 visits per-year, is not anticipated to be a problem. Although not compensated fi-

nancially, the visits offer the participating professionals rewarding public service opportunities that are meaningful learning experiences. In addition, the visits offer an opportunity to see new areas and communities while participating in a professionally stimulating and challenging interdisciplinary problem-solving experience.

The process is dynamic. Although the basic structure of the process has not changed, certain details evolve over time as teams learn what does and does not work in small communities. This is particularly true for the structured exercises used in the community meetings. As the process moves to incorporate watershed visits, it will be important to more formally evaluate successes and failures so that the visits will continue to serve West Virginia communities effectively.

The CDT process can be considered as another tool for public participation in the transportation planning/design process. The process appears to have particular applicability in the area of context-sensitive design. The relationship between the two is worthy of more formal examination.

Because it makes use of "local" professionals familiar with in-state issues, the CDT process is readily transferable to other regions of the United States or to other countries. In fact, the process used in the West Virginia CDT program was transferred from Minnesota where it originated. A similar process, tailored to local resources and constraints, exists in Virginia. Transportation professionals interested in exploring the potential of the CDT in their location are encouraged to experience the process by participating in a visit with one of the ongoing programs.

References

1. "When Main Street is a State

Highway," State Highway Administration, Maryland Department of Transportation, Annapolis, MD, 2001.

2. "Community Design Team Manual," Cooperative Extension Service, West Virginia University, Morgantown, WV, undated.

3. "Context Sensitive Design-- Executive Summary," Center for Transportation Studies, University of Minnesota, Minneapolis, MN, undated.

For more information, contact either Ronald W. Eck at (304) 293-3031 ext 2627 or at Ronald.Eck@mail.wvu.edu, Michael R. Blankenship at (304) 293-3031, ext 2629 or at mblanken@wvu.edu, or William D. Wyant at (304) 296-7463 or at wwyant@hsc.wvu.edu.



Iowa's Low-Cost Strategy for Delineating Utility Poles

From FHWA's "Technology Talks"

In Iowa, crash-prone utility poles located near the roadway are being wrapped with a 150 mm (6-inch) band of white reflective tape. Although the preferred methods of mitigating high-crash locations involving utility poles are either to remove or relocate the poles, research from a Pennsylvania study has shown a 25% reduction in night-time utility pole hits after the poles were delineated. The first sites in Iowa to receive the delineation treatment are in Muscatine, Iowa, which has the first, second and 15th ranked high-crash locations involving utility poles for the state. The crash data information used to identify candidate sites was obtained from a study conducted by the Center for Transportation Research and Education (CTRE), Iowa State University. ▲



LTAP Centers Bring Resources to Local Agencies

LTAP Clearinghouse, Washington DC

Over three million miles of road and 29,000 bridges in this country are owned and managed by counties, parishes, townships, cities, and towns. These roads, streets, and bridges often encounter excess wear due to traffic, weather, and mistreatment. Keeping them safe and operational requires maintenance, upgrades, and rehabilitation.

Limited funding for this work has created a significant need for technical assistance to the 38,000 local communities across the United States. In 1982, the Federal Highway Administration (FHWA) recognized the need for local communities to come together to share resources, training, and technology transfer by creating the Local Technical Assistance Program (LTAP).

LTAP's mission is to foster a safe, efficient, environmentally sound transportation system by improving the skill and knowledge of local transportation providers through training, technical assistance, and technology transfer.

LTAP is composed of a national network of centers - one in every state, Puerto Rico, and regional centers serving tribal governments. These LTAP Centers enable local counties, parishes, townships, cities and towns to improve their roads and bridges by supplying them with:

- A variety of training programs.
- An information clearinghouse.

- New and existing technology updates.
- Personalized technical assistance.
- Newsletters.

These core services provide access to training and information that may not have otherwise been accessible. Centers are able to provide local road departments with:

- Workforce development services.
- Resources to enhance safety and security.
- Solutions to environmental, congestion, capacity and other issues.
- Technical publications.
- Training videos and materials.

Local transportation agencies have saved \$8 for every \$1 LTAP spends on information and training. The economical benefits of the program equal the quality of service rendered. LTAP centers are annually:

- Reaching over 12,500 local communities.
- Training more than 115,000 people at over 4,000 training sessions.
- Sending newsletters to more than 131,000 local contacts.
- Distributing 250,000 materials to local agencies.

Each mile of road that connects friends and neighbors, moves

goods and service, and insures timely response for public health, safety and security has benefited from the services LTAP Centers provide.

Consider how LTAP can be of assistance to you:

- Sign up to receive your state's newsletter.
- Participate in a training program.
- Schedule a training to address your workforce needs.
- Request a publication or videotape.
- Learn the latest transportation information.
- Utilize the resources they have available.

The LTAP is administered in the state of Washington by the Washington State Technology Transfer (WST2) Center, an office within the Highways and Local Programs Division of the WSDOT and can be reached at (360) 705-7386, e-mail wst2@wsdot.wa.gov. The WST2 web site is located at:

www.wsdot.wa.gov/TA/T2Center/T2HP.htm

To learn more about LTAP, contact the LTAP Clearinghouse (202) 408-954, visit www.LTAPT2.org or contact the WST2 Center.



The STOP (R1-1) Sign



Figure 1. A properly installed STOP (R1-1) sign stop line, and crosswalk.

and Supplemental Devices



Figure 2. A properly installed Stop Ahead (W3-1a) sign.

Reprint from University of New Hampshire Technology Transfer Center: <http://www.t2.unh.edu/summer02/pg6.html>

Motorists must always stop at a STOP (R1-1) sign. Moreover, motorists and pedestrians expect them to stop. Proper placement is essential to inform road users and to preserve respect for the most important of traffic signs. User respect is also maintained by installing STOP signs only when necessary.

This article describes how municipalities should install STOP and supplemental signs and pavement markings. It also discusses using STOP signs to control speed.

First, a note about the Manual on Uniform Traffic Control Devices (MUTCD), it governs traffic control devices with standard, guidance, and option statements of practice. In this article the words "shall" or

"required" are used for standard statements, "should" or "recommend" for guidance, and "may" or "permitted" for option.

Sign and Marking Installation

Figure 1 shows one of three STOP signs at a T-intersection. It illustrates a properly installed set of traffic control devices

The STOP sign has the required white on red retro-reflective sheeting and standard letters. It is 30 by 30 inches, the required size for conventional roads. It is located on the right side of the traffic lane, and as close as practical to the intersection. The lateral offset (measured from the road

or shoulder edge to the near edge of the sign) is 6 feet, the required minimum.

The almost 6 foot mounting height (measured from the pavement edge to the bottom of the sign) exceeds the required 5 foot minimum for "rural districts." The MUTCD requires 7 feet "where parking or pedestrian movements occur" to reduce the risk of pedestrians hitting the sign. In this instance, the sign height and distance off the sidewalk achieves this purpose.

The 3-Way (R1-3) supplemental plaque is required where STOP signs control all approaches. In Figure 1 it is in poor condition and should be replaced. It shall be 12 by 6 inches, white letters on a red background, and retro-reflective. It may have a mounted height a foot less than the STOP sign.

The painted stop line is properly installed. It is the required solid white line extending across the approach lane. As recommended it is 12 to 24 inches wide with similar spacing,

and is placed where the road user should stop. Being 4 feet in advance of the crosswalk, it conforms to the New Hampshire Dept. of Transportation Standard. (Without a marked crosswalk, the stop line should be placed at the desired stopping point, and between 4 and 30 feet from the nearest edge of the intersecting travel way.)

The crosswalk shown is the MUTCD Standard. The crosswalk lines are the required white stripes between 6 and 24 inches wide with similar spacing. They are the recommended 6 feet (at least) in length. (Two other layouts are permitted; see MUTCD Chapter 3B, Figure 3B-15.)

The Stop Ahead (W3-1a) sign is required where a STOP sign is not visible for a sufficient distance for motorists to respond. MUTCD Chapter 2C, Table 2C-4 provides recommended distances. For the

35 mph road in Figures 1 and 2, the recommendation is 150 feet. At that distance the illustrated STOP sign is visible, but the W1-3a is still permitted. With the foliage and unexpected need to stop, the Stop Ahead sign is probably a good idea. The Stop Ahead sign, at 160 foot from the STOP sign, exceeds the recommended warning to motorists.

The W3-1a sign in Figure 2 is of the required size (30 x 30 inches), color (yellow with black and red symbols) and offset (greater than 6 feet). Here too, the 6-foot mounting height is adequate. The MUTCD permits mounting on a utility pole.

This illustrates that more traffic control devices than the R1-1 are usually needed. All devices must be properly installed and maintained for motorist and pedestrian safety.

The STOP Sign as Speed Control

The MUTCD recommends STOP signs only when one of four conditions exists (See MUTCD Section 2B.05). It also states "STOP signs should not be used for speed control." The illustrated STOP sign, however, has that purpose. After a car struck a child, residents petitioned for a 20 mph speed zone. The Town Council was reluctant to set such a low speed limit. Instead, it directed the STOP sign be installed.

Municipal officials often face similar decisions. They must balance resident wishes against more effective, but also more expensive, ways to calm traffic. In the examples in Figures 1 and 2, residents are generally happy with the STOP sign. Perhaps they don't appreciate that the road might not be significantly safer with it. The Institute of Traffic

WST2 List Serves - Improved Communications At Lower Cost

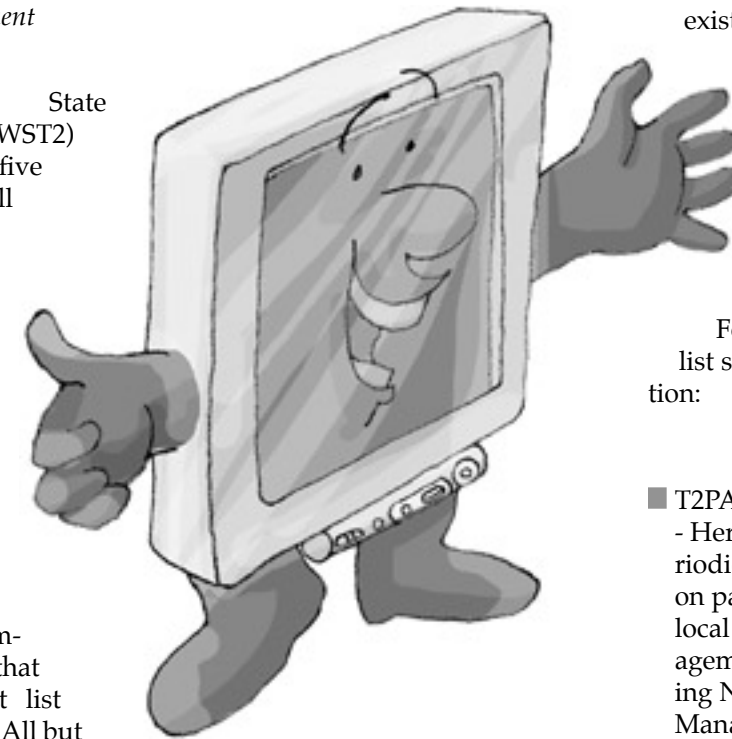

Bob Brooks, WST2 Pavement Technology Engineer

The Washington State Technology Transfer (WST2) Center administers five separate list serves, all providing improved communications and information sharing while lowering the cost of providing these services.

In simple terms, a list serve is an automated mailing list that you, the end user, can subscribe and unsubscribe to at will. The list serve is comprised of all the folks that are subscribed to that list serve at any given time. All but one of the WST2 list serves is designed to provide interactive communications among the subscribers and information sharing from the WST2 Center. The T2News-L list serve is used by the WST2 Center only for distribution of an electronic version of the newsletter each quarter. Each list serve has been established to provide information exchange in a unique subject area.

A subscriber can logon to the list serve anytime and immediately send a message to all the other subscribers requesting information. The other subscribers can then respond to these requests by sending back a message to the individual subscriber or to the list serve as a whole. This can be a very effective way for the subscribers to tap into the vast pool of knowledge that

exists out there and exchange information at no cost to their agencies. And we, at the WST2 Center, use these list serves to send out information and announcements within the list serve subject areas

Following is a listing of the list serves available for subscription:

- T2PAVE-L@lists.wsdot.wa.gov - Here you will receive periodic technical information on pavement technology and local agency pavement management information including Northwest Pavement Management Association (NWPMA) information, and any late breaking technical information and announcements.
- T2SMS-L@lists.wsdot.wa.gov - The Safety Management list serve is committed to the sharing of information between local agencies. This list serve delivers information and resources, covering the latest in traffic technology, traffic safety, roundabouts, and safety management and safe communities.
- T2News-L@lists.wsdot.wa.gov - This list serve distributes the WST2 Newsletter, a quarterly periodical dedicated to covering a wide range of technical topics to assist Washington State communities and local governmental agencies.

A subscriber can logon to the list serve anytime and immediately send a message to all the other subscribers requesting information

and many have failed. One reason for failure is residential objection. These measures slow traffic by inconveniencing motorists. Residents, who drive the roads frequently, are most inconvenienced.

Sources

- Guidelines for Design and Application of Speed Humps -- A Recommended Practice. 1997. Institute of Transportation Engineers.
- Manual of Uniform Traffic Control Devices, Millennium Edition with Errata 1 Changes. 2001. Federal Highway Administration. <http://mutcd.fhwa.dot.gov/kno-millennium.htm>
- Traffic Calming: State of the Practice. 1999. Institute of Transportation Engineers.
- Traffic Signing Handbook. 1997



construction staging, provide temporary use of city streets for detour routes during nighttime demolition and erection of falsework/girders, and provide modification/closure of existing city streets to accommodate the new bridge. The City will also provide the use of their new stormwater detention and treatment facility, which will be a huge cost savings to the department. The project will be advertised January 2003.

For more information on this project, contact Dave Crisman, WSDOT NW Region Acting Project Engineer, at (360) 428-1593.



Engineers (ITE) analyzed studies of speed before and after unwarranted STOP signs. They found that motorists reduced speed only a short distance before such a STOP sign. Mid-block speeds decreased slightly on average and in a few cases increase. Within several hundred feet past a STOP sign, many cars travel as fast as if no sign existed. Moreover, as motorists accelerated from the sign, they had reduced ability to stop for an emergency.

Vehicle acceleration also increases air pollution. In addition, overuse decreases motorist respect for this important sign. While the author took the Figures 1 and 2 pictures, 17 cars rolled through the STOP signs; one came to a complete stop. This is consistent with studies that show less than 10 percent of drivers actually stop for unwarranted STOP signs.

Speed humps, rounded raised areas placed across the road, can be

effective speed control measures if properly designed and spaced. ITE has a recommended design for a 12-foot long speed hump, 3 to 4 inches high. The design speed is 15 to 20 miles per hour. Shorter humps act like speed bumps, which are no longer used due to many lost liability suits.

Speed hump spacing depends on the desired midpoint speed. For example, 200 to 250 foot spacing is needed to have an average 20 mph midpoint speed. They cost from \$2000 to \$2500 each.

Speed tables, essentially long speed humps, are usually 22 foot long with a textured material on the flat section. Fire departments usually prefer them to speed humps. They slow the traffic less than speed humps.

Other speed control measures include narrowing parts of the road or deflecting traffic with chokers or islands. Some have been successful,

WSDOT Uses Context Sensitive Solutions to Get the Job Done!

In the spirit of true "Community Partnership" and "Context Sensitive Solutions", WSDOT and the city of Mount Vernon are partnering to add a third lane to WSDOT's 2nd Street Bridge Replacement project. While this type of partnering or meeting community needs is not new to WSDOT, the department is encouraging a more focused effort in these areas to better accommodate community and transportation needs and leverage limited resources.

The third lane will help to meet community needs by:

- Providing a remedy to future deficiencies of the bridge.

- Serving as a truck lane or dedicated turn lane.

- Serving the ingress and egress of the City's future multi-modal facility.

- Providing bicycle and pedestrian access.

Because there was no additional funding to add the third lane, a Memorandum of Understanding has been executed between the City and WSDOT, where the department will add the third lane to the new bridge and the City will provide right of way and easements along the bridge and retained approaches, lease existing parking area for

■ T2TRNG-L@lists.wsdot.wa.gov - By subscribing to this list server, you will receive the training opportunities and resources available through the WST2 Center.

http://T2TRNG-L@lists.wsdot.wa.gov/guest/RemoteListSummary/T2TRNG_L

■ TRAIN-L@lists.wsdot.wa.gov - The acronym TRAIN stands for Training Resource And Information Network. TRAIN is a network of inter-agency training departments sharing training resources. This site will be used to post training opportunities, available classes, and news about TRAIN.

http://TRAIN-L@lists.wsdot.wa.gov/guest/RemoteListSummary/TRAIN_L

2. Type your e-mail address, select Immediate Delivery or Digest Delivery and click the submit button. If you wish to unsubscribe from a list, enter your e-mail address, select Unsubscribe and click the Submit button.

3. You may receive a message back telling you the subscription was delayed for address verification. Ignore this message and close the Internet browser window.

4. You will next receive an e-mail from the list serve requesting an address verification for subscription. Just select reply and send, there is no need to enter any text in the reply message.

5. You will receive confirmation e-mail and a welcome message from the list serve that you subscribed to.

The T2SMS-L list serve is slightly different. Once you enter your subscription information on the Internet and submit, you are automatically subscribed and won't need to send back any e-mail verification. Once subscribed to one or all of the list serves, you can then participate in the information exchange and receive all the announcements that are forwarded through the list serve.

To subscribe to any of the list serves above use the following procedures:

1. Type in one of the following addresses in your Internet browser address line and enter.

http://T2PAVE-L@lists.wsdot.wa.gov/guest/RemoteListSummary/T2PAVE_L

http://T2SMS-L@lists.wsdot.wa.gov/guest/RemoteListSummary/T2SMS_L

http://T2News-L@lists.wsdot.wa.gov/guest/RemoteListSummary/T2News_L



To post a message to the list serve, type into an e-mail address window the list serve address shown in the listing above (e.g., T2PAVE-L@lists.wsdot.wa.gov), type your message and send. Your message will go to everyone subscribed to that list serve. Enjoy. ▲



The "Better Mousetrap" is awarded each quarter for the most innovative working ideas presented by a public agency and published in WST2.

Award:
The best concepts will be published in the WST2 and posted on the WST2 Web Page.

Published mousetraps will receive a "Better Mousetrap" baseball cap and certificate.

Published mousetraps will be included in competition for the annual "Crystal Mouse" award.

Eligibility:
Washington State Public Agencies.

Mail To:
"Better Mousetrap"
WST2 Center/WSDOT
P.O. Box 47390
Olympia, WA 98504-7390

E-mail:
WST2Center@wsdot.wa.gov

For questions:
Dan Sunde,
Technology Transfer Engineer
SundeD@wsdot.wa.gov
(360) 705-7390

"Better Mousetrap" Submittal Form

Agency: _____

E-mail Address: _____

Address: _____

City: _____ State: _____ Zip+4 _____

Phone Number : (_____) _____

Developer's Name(s): _____

Title: _____

Agency: _____

E-mail Address: _____

Address: _____

City: _____ State: _____ Zip+4 _____

Description of the "Better Mousetrap"

Why was it necessary? _____

How does it work? _____

How was it built? (Include Sketches, Photos, Drawings) _____

How does it perform? _____

Please add a sketch with dimensions and materials used!
We will draw plans from them so others can build it too!

Guardrail Post Screw

Jim Simmons, WSDOT SW Region, Kelso-St. Helens Maintenance Supervisor

Through a few guardrail repair jobs, several Maintenance Techs from the WSDOT Kelso Shop had brainstorming sessions on a better way to remove broken guardrail posts from the soil. Removing broken posts consisted of digging down and around the broken stub using shovels, post hole diggers and, sometimes, hands; find enough good wood to wrap a chain around; and use a hoist, dump truck box, or the brute force of 1 or 2 people to pull the post out. Loose materials or rain and mud made this job tough and sometimes dangerous. It was never a pleasure to lie on your stomach in dirt, dig by hand, and work the chain around to get it into the wood. A series of shorter lag bolts and chains were used, but it was hard to find good wood as the posts were usually splintered or rotted. The crew decided that a very long tool that could be screwed into the ground and into the post might work. They approached Don Avery, retired Mechanic 1 from the Kelso Transportation Equipment Fund (T.E.F.) Shop, about building a prototype giant screw. The idea was to build the screw out of thick stock to prevent bending. The crew used 1-1/4 bolt stock to build the screw. T.E.F. was not set up to thread the stock so it was sent to a machine shop in Longview. The bolt head also had to be machined down to 1-1/4" hex to fit the same socket used on the guardrail bolts. A piece of 3/8-inch

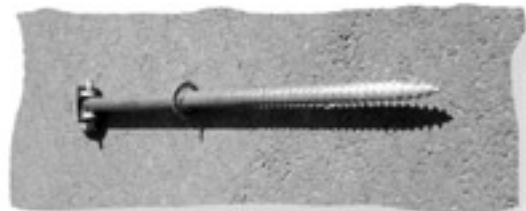
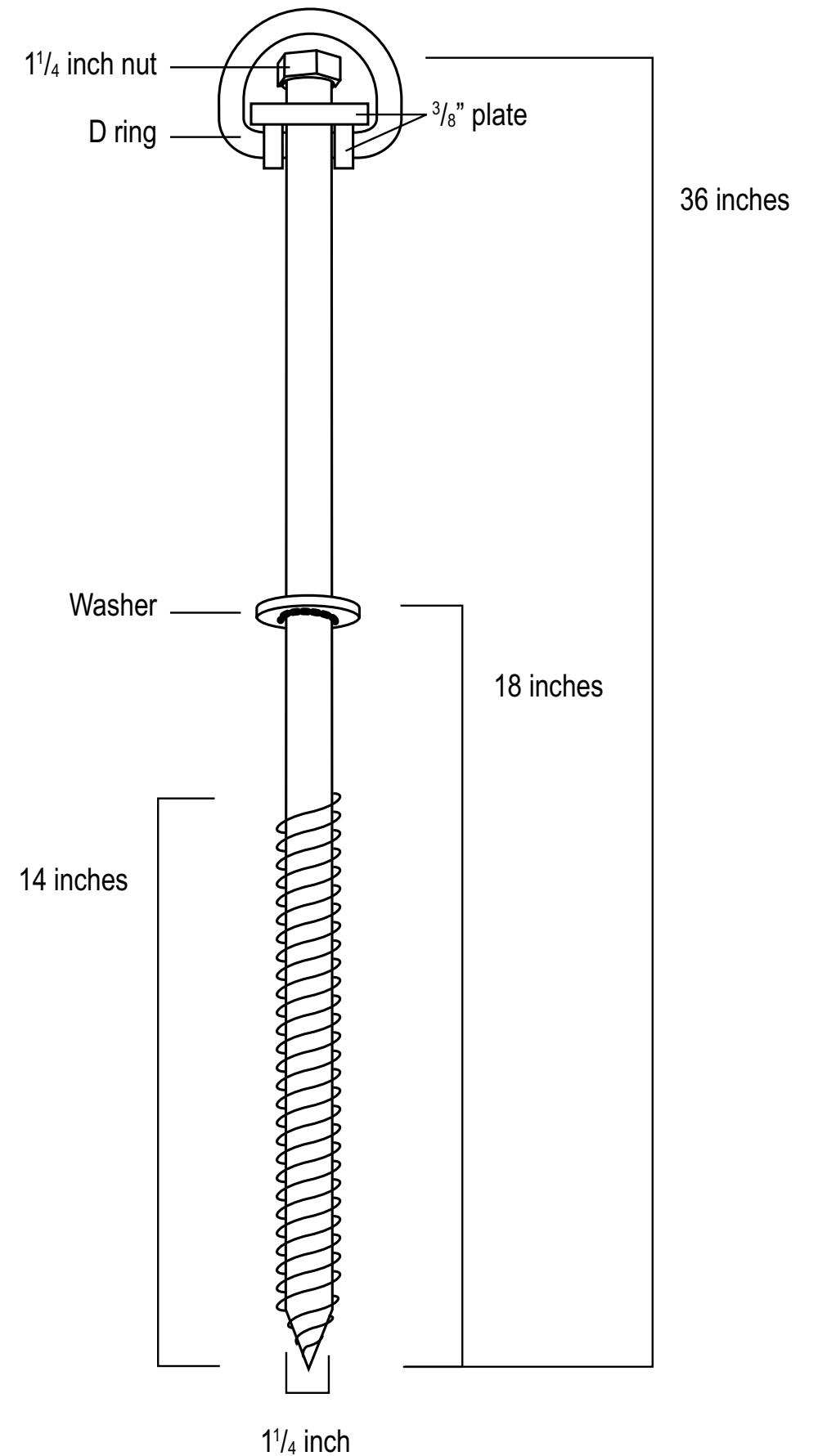

plate was fitted with ears welded to it and a D-ring. This was then drilled to accommodate the shaft of the screw. A large washer was welded to the shaft of the screw to keep the lifting eye from sliding off, but enough room was allowed so that the lifting eye would not be in the way during the installation process. The air tanks on the dump trucks have fittings to plug an air hose into for supply to the air ratchet. To remove a guardrail post, the location of the post is determined and the screw is drilled directly into the post or into the dirt above the post until it is firmly planted into good wood. A chain is attached to the D-ring and the broken post is

pulled from the ground. While there is no good data from past jobs to verify timesavings, the crew believes that using the guardrail post screw is easier, faster, and safer than the old way of removing posts. There is less digging, no pulling and straining, no lying in the mud, etc. The cost of the screw was between \$200.00 and \$300.00 including the cost of materials and machine shop work. ▲



Steve Potter and Mike Albright's Mobile Work Zone Traffic Control (WZTC) Cone and Sign Storage



Mike Albright, WZTC Sign & Storage Fabricator



Steve Potter, WZTC Sign & Storage Inventor



WZTC Truck Sign Stand Storage



WZTC Truck Cone Storage

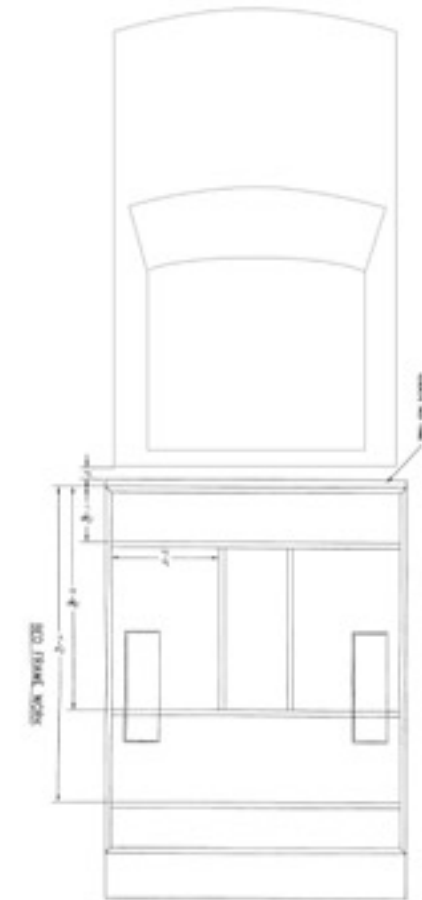

By Sharon McLeod-Everette, Alaska Technology Transfer Center, Alaska DOT (ret.). Reprinted by permission from the Alaska Exchange, Spring 2001, vol.26, no. 1

As Steve Potter, equipment operator for Alaska Dept. of Transportation and Public Facilities', Northern Region Maintenance & Operations in Fairbanks, watched workers set out and pick up cones and signs for mobile work zone traffic control, he noticed a few things. First, there was no place to efficiently store cones, signs, and sign stands - they got jumbled up in the bed of a pickup. It was awkward for workers to lift the heavy signs and stands over the side of the bed to place the signs, and the same was true for replacing the signs. Cones

would get stacked together and then signs and stands would fall over on them. Second, people had a tendency to throw trash into the bed of the pickup. It was messy. Potter saw a need for a better way to handle the cones and signs and penned a conceptual drawing. Mike Albright, another Fairbanks operator, took Potter's concept drawing and went to work. He built storage components into the flatbed of the truck specifically to accommodate setting out and picking up cones, signs, and stands. By putting their heads together, Potter and Albright developed a safer and more efficient means for their traffic control workers to deal with cones and signs. Clutter no longer builds up in the bed of the pickup because the flatbed is, in a

word, flat. The flatbed has no sides, so there's no lifting over the side to dump the signs, etc. into the bed or to get them out. The bed is aluminum and is customized for specific work zone items. The stand holders and sign racks are steel. Albright produced raised pinnacles to stack cones, recessed containers for sign stands, and created racks for the signs. Potter and Albright put these components on a truck that can also be used as a pilot car. It has cautionary lights on a headache rack just behind the cab. Material costs for the aluminum and steel run about \$1,500, according to Albright. Alaska DOT Northern Region is now building its third WZTC truck.

Potter, who was nominated by his supervisor, recently received an AASHTO award for recognizing the need for a safer, more efficient way to deal with traffic control tools and then using his can-do ability to conceptualize the drawing. Albright deserves kudos as well for manufacturing the truck.

For a copy of the drawing and specs, contact Steve or Mike at (907) 451-2205 or email Alaska DOT Fairbanks Area Manager, at david_waldo@dot.state.ak.us

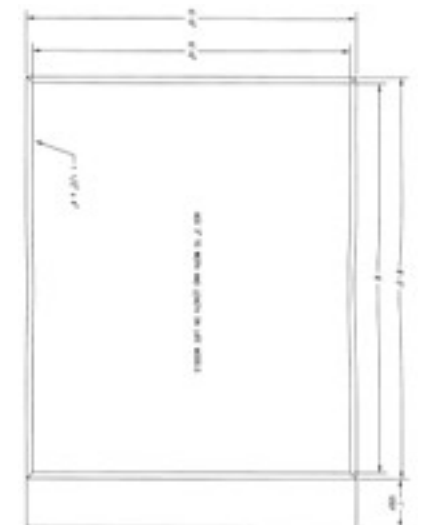
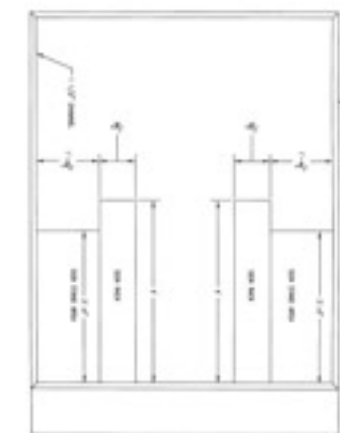

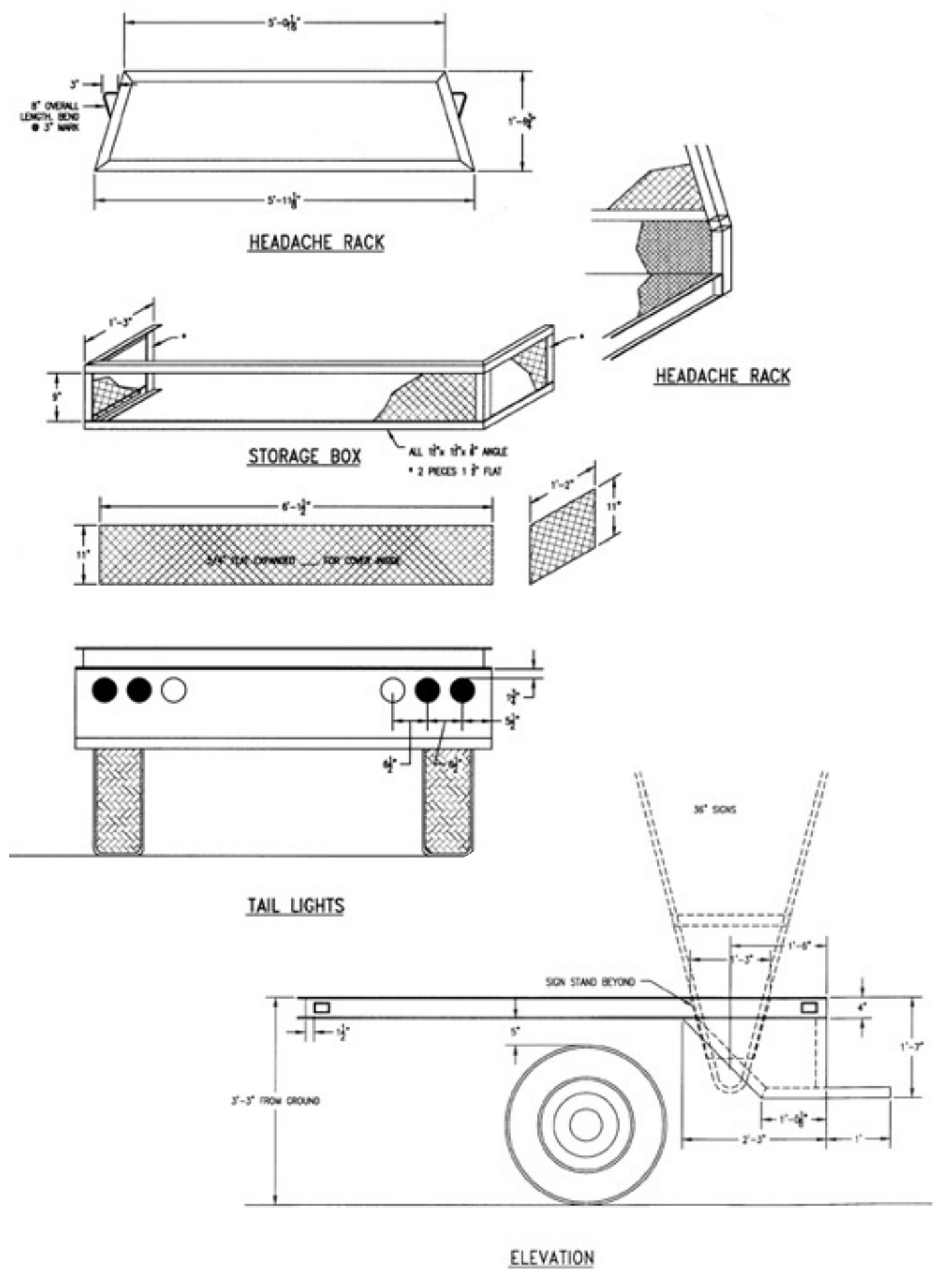
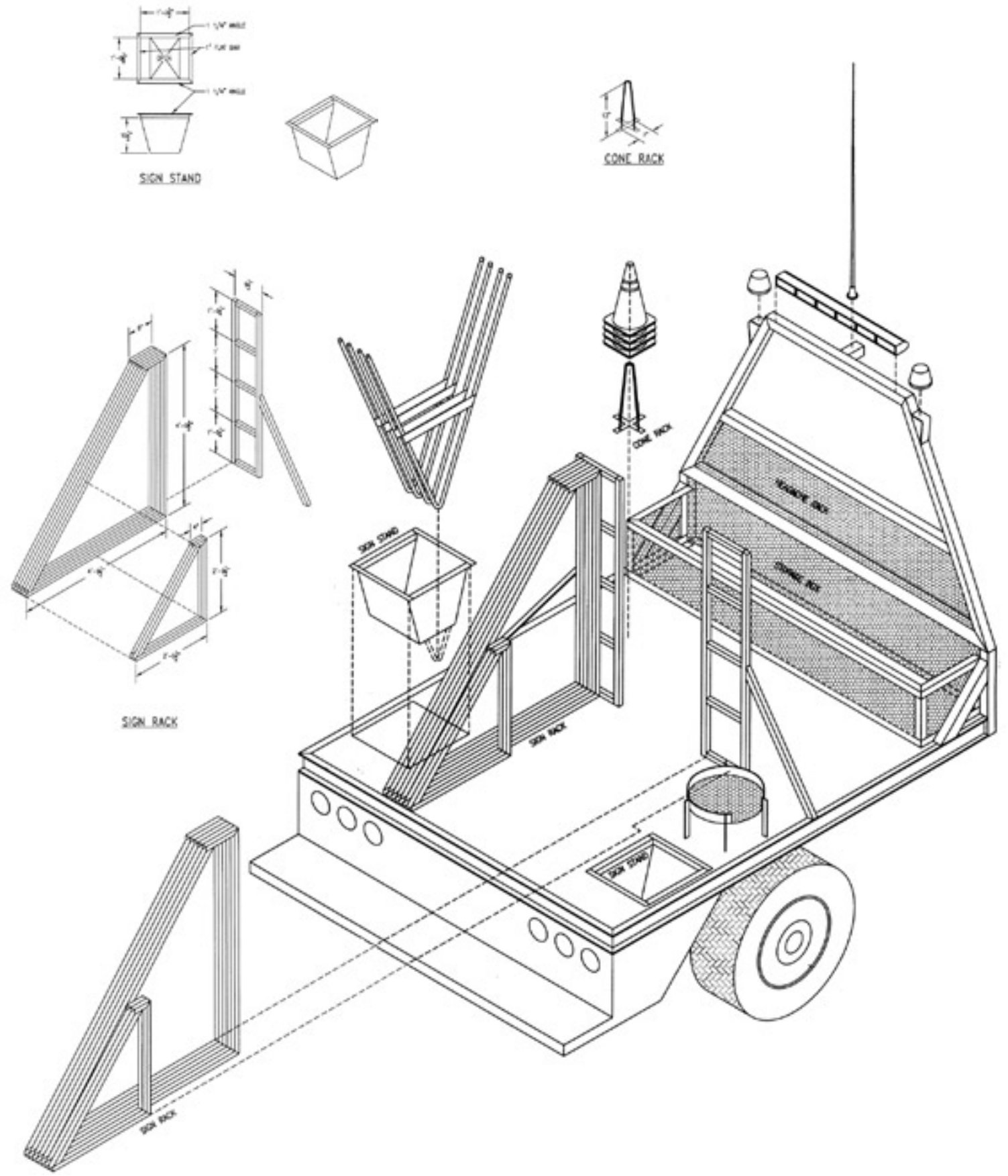

2002 Awards of Excellence Winners

The Awards of Excellence program is a collaborative effort between FHWA and WSDOT to formally recognize projects that excel in the areas of safety, design, construction, project administration, cost effectiveness, environmental compatibility, enhancement to the transportation system, and public satisfaction. The city agency awards were presented on October 31, 2002 at the APWA Fall Conference in Spokane. The county agency award was presented on October 2, 2002 at the Washington Association of County Officials (WACO) and the Washington State Association of Counties (WSAC) Joint Annual Conference in Wenatchee. The following 2002 Awards of Excellence winners demonstrate a high level of quality.



Best City Project: City of Bremerton SR 304 Gateway Project

The SR 304 Gateway Project is part of the larger SR3/304 Transportation Improvement Project, from Gorst to the Bremerton Ferry Terminal. The SR 3/304 project was created to address congestion, safety, and access issues on the route. Particularly interesting about this project is that while it is on a state highway, the city of Bremerton took on the project for the benefit of its citizens and the highway users, recognizing the mutual benefit and need. An important characteristic of the SR 304 Gateway Project is its safety improvements. Previously, the roadway was an undivided, narrow road with sharp substandard curves, uncontrolled access, poor or limited sidewalks and crosswalks, limited ADA access, and no defined bike access. The project provided excellent safety enhancements by adding a raised median (acting as both a traffic separator and pedestrian refuge), auxiliary turn lanes, complete realignment of the road, signalization, curbs and gutters, sidewalk separation, bike lanes, a cantilevered overhead crosswalk sign, illumination, and limited access.

Funding sources for the SR 304 Gateway Project included approximately \$15.9 million in federal funds and \$12.8 million in local funds. The WSDOT contact for this project is Mike Horton at (360) 357-2666 (Tumwater).



Best County Project: Klickitat County Alderdale Road

The Klickitat County Alderdale Road project demonstrated sound engineering in a rural area and was successful for three reasons. First, the project provided for a safer roadway for traffic that has increased greatly as a result of more corporate-style farming in the area. Secondly, this project provided a year-round all-weather roadway into one of the fastest growing agricultural areas in Washington. Lastly, because the Alderdale Road project was tied to a WSDOT paving project on SR 14, there was an estimated savings of \$1.4 million in contract and engineering costs. The merger of the projects brought in WSDOT administration and inspection expertise. By combining the administration/inspection of the two projects, both Klickitat County and WSDOT realized savings in construction engineering.

Funding sources for the Alderdale Road project included approximately \$3.3 million in federal funds and \$550,000 in local funds. The WSDOT contact for this project is Bill Pierce at (360) 905-2215 (Vancouver).



Best Enhancement Project: City of Raymond Willapa Hills Trail

The Willapa Hills Trail project involved the construction of a 1.6-mile portion of the cross-state rail trail from the SR 101 intersection along SR 6 to the city limits of Raymond on the former Burlington Northern Railroad corridor, which is now owned by State Parks.

Prior to construction, pedestrians and bicyclists had two choices: (1) travel on the shoulder of SR 6, which at this section is narrow and winding or (2) travel on the abandoned rail corridor over a dilapidated and dangerous bridge and over the weed choked, uneven railroad ballast. Construction of the trail from the east city limits to SR 101 supplied a safe separated paved pathway from the community in the valley east of town into the downtown core. Also, by providing a small parking lot at the eastern boundary of the project, people are encouraged to leave their cars and walk or bicycle into town. As a result, the construction of the trail provided both visual and functional improvements.

Funding sources for the Willapa Hills Trail project included approximately \$90,000 in federal funds and \$59,000 in local funds. The WSDOT contact for this project is Bill Pierce at (360) 905-2215 (Vancouver).



Best Special Project: City of Olympia Indian Creek Stormwater

The Indian Creek Stormwater project is designed to treat stormwater runoff, which flows off I-5 into Indian Creek. The facility design includes sedimentation ponds, plants, bioengineered crib walls, rocks, waterfalls, and weirs. Walking trails, landscape, and views of the stormwater cleansing process transforms this facility into a publicly accessible site.

The goal of this extremely unique and successful project is to improve water quality to Indian Creek through the use of native materials. This project is a direct result of legislation that encourages such multi-agency projects. This is also one of the first stormwater treatment projects of its kind that utilizes natural means for water treatment. The sedimentation ponds remove the larger materials, and the constructed wetlands remove contaminants through plant interaction and permeation. Each of the plants is native to Washington and chosen for soil retention, appearance, and ability to discourage people from accessing specific areas of the site.

Funding sources for the Indian Creek Stormwater project included \$167,897 in federal funds and \$272,000 in local funds. The WSDOT contact for this project is Mike Horton at (360) 357-2666 (Tumwater).



Steamboat Slough Bridge Project Activities Alleviate Traffic Impacts Demonstrating Quality Construction



Garco Construction Corp. removing the old concrete bridge deck.



Preparing for a deck pour on the center span



Ceremonial ribbon cutting on the SR 529 Steamboat Slough Bridge

By Amir Ahmadi, WSDOT NW Region Project Engineer

The Steamboat Slough Bridge Project will upgrade and repair the Steamboat Slough bridges (southbound and northbound) on State Route 529 between Everett and Marysville to make them safer and longer-lasting, saving taxpayer money. Work includes electrical and mechanical rehabilitation of the swing span controls and drives, cleaning and painting the steel structure, and strengthening the bridge to better withstand earthquakes.

Between May 14 and late-July 2002, the project reduced capacity and changed the alignment of SR 529 between Everett and Marysville

with the southbound Steamboat Slough bridge lanes completely closed. To alleviate the traffic impacts of the closure, the Washington State Department of Transportation (WSDOT) utilized northbound bridge lanes as a reversible bridge to accommodate AM and PM peak hour traffic. Instead of the northbound bridge being used as a one-lane, one-way direction, it was converted to two-lanes one-way southbound in the morning and two-lanes one-way northbound in the afternoon Mondays through Fridays and one-lane each direction over the weekends.

Also, a huge public relations campaign began by sending out fliers to affected communities, businesses and media to alert them about the

upcoming closure and inform them about the reversible operations. The campaign also included:

- Presentation to adjacent city councils.
- Power Point presentation of the project at Neighborhood Meetings to the local residence and businesses.
- Provided a manned booth at nearby community college (trip generator).
- Visited individual businesses affected by the upcoming closure.
- Provided project specific schedule and upcoming traffic revisions to local media (news-papers, radio and television stations).

- Provided project specific web site.
 - Provided commuter alert through regularly published department's news.
 - Utilized Department's experts to provide live broadcast on radio and television stations.
- To alleviate traffic impacts, WSDOT also provided:
- The new traffic configuration was coordinated very closely with local officials to ensure that their concerns are addressed.
 - An agreement between WSDOT and the local transit agency to provide additional bus runs for an alternative mode of transportation.

- A hot-line number for commuters to call in for information and complaint.
- Four traffic cameras within the project limits to provide up to the minute visual images of the traffic flow.

- Use of WSDOT push trucks to remove disabled vehicles from the immediate roadway.
- A new temporary park and ride site.
- Additional detour routes for accessing adjacent freeway and increased detour signage.
- Incentives to contractors for early completion.
- Two Highway Advisory Radios (HAR) at both ends of the project to alert and provide information on the project and alternative routes.
- Temporary ramp metering technique at key point to regulate traffic merges.
- Color pamphlets to all affected business owners with information on how to utilize adjacent

roadways to commute through the construction site for their use and distribution to their customers.

- A "Command Center" including multi jurisdictional staff as well as specialists inside the center and on critical locations within the project limits to make adjustments instantaneously including helicopter flight to monitor and evaluate the traffic flow from bird's eye view to handle potential congestion problem.

The results of these activities were amazing. There were no unusual backups and no congestion was observed or reported, the media reported smooth traffic flow, and WSDOT received numerous public acknowledgements and appreciative telephone calls.

On July 24, 2002 (nearly 86 days earlier than original contract time), the southbound bridge lanes were open to traffic and a ribbon cutting ceremony was held. Ceremony attendees included Ron Paananen,

WSDOT NW Region Deputy Regional Administrator, and city of Marysville council members. The success of this phase of the project is due to the extraordinary efforts of:

- Klara Fabry, WSDOT NW Region Assistant Regional Administrator Snohomish Area
- Timothy Smith, WSDOT NW Region Engineering Manager Snohomish Area
- Steven Miller, WSDOT NW Region Engineering Manager Snohomish Area
- Amir Ahmadi, WSDOT NW Region Project Engineer and staff; and
- Mowat Construction Company, Contractor

For more information about this project, contact Amir Ahmadi, WSDOT NW Region Project Engineer, at (425) 357-5109 or ahmadi@wsdot.wa.gov.



Successful Partnerships for US 12 Phased Projects

By Kim Vaughn, WSDOT South Central Region Project Development Office

WSDOT has recently completed the design and contract plans for the first of several phased projects on US 12 between its junctions with SR 124 and SR 730. This series of projects will increase capacity by adding two additional lanes to the existing US 12 highway alignment, which is expected to enhance the safety and economic development of this and the surrounding areas.

The conceptual idea for this series of projects began as a cooperative action between WSDOT, Walla Walla County, the port of Walla Walla, and several interested private groups.

The conceptual idea for this series of projects began as a cooperative action between WSDOT, Walla Walla County, the port of Walla Walla, and several interested private groups. This effort became more organized, and gathered more sup-

port, to the point that WSDOT was able to program the first project. This first project was significant, in that it accomplished two major elements. First, this project crosses the McNary National Wildlife Refuge, and second, the environmental mitigation and documentation for this project provides for the entire multi-project corridor.

In order to facilitate the environmental permit and approval process, WSDOT partnered with several agencies. These agencies included the US Army Corps of Engineers, US Fish and Wildlife Service, US Bureau of Reclamation, the National Marine Fisheries Service, Washington Dept. of Fish and Wildlife, and several Native American Tribes. Acceptance of the project was achieved by constant and timely communication between WSDOT and participating agencies. Due to timeline constraints and the number of agencies involved, a strategy was chosen including field reviews with representatives of these agencies as one of the primary tools for the success of the project objectives. This strategy proved effective in providing an understanding of what was being proposed and delivering what was needed as efficiently as possible. Extensive review of the produced environmental documents was pushed along to include comprehensive reviews by all involved parties.

The design of this project proved to be as much of a challenge as the environmental elements of the project.

Since this project included many elements not typically encountered on a transportation project, change was constant. From designing an "undulating shoreline", to a new boat launch, to a 24-acre mitigation site, there were constant challenges. Meeting these challenges was enhanced by continued discussions between WSDOT's Environmental, Construction, and Design Offices.

Once the projected ad date approached, WSDOT faced one of many critical debates about what funding would fund which projects. This project was cut and then brought back to life through strong local and regional support, in addition to the support shown by several members of the state legislature. The project is now fully funded for construction and going on ad this fall. Only through the partnerships among supporters, agencies, and WSDOT was the success of this project possible.

For more information about this project, contact Kim Vaughn, WSDOT South Central Region Design Squad Supervisor, at (509) 577-1706.



Words from the Chair

This will be the last message from me as your Chairman for this fine organization. I am proud of this group for the accomplishments made and the general cooperation of the members in the work that went into the conferences held this year. Without your cooperation and that of the executive board, we could not have done this well. Thank you all for your help.

This construction season is drawing to a close. I hope the lessons learned will be shared among us all at the fall conference, which will be held before this issue comes out.

We, here at the Ada County Highway District, have had a successful season with over 50 miles of pavement added from subdivisions, 2 miles of gravel roads paved, 200 miles of road chip sealed, 8 miles of asphalt overlay, and 1 mile rebuilt. This does not count the special projects starting this fall and winter. We used the "GlasGrid" product from California Paving Fabrics, Inc. on 1 mile of road to, we hope, eliminate cracking from showing through. We sealed the cracks on half the road and nothing on the other half, and applied the grid to all cracks paved with 1.5 inches of asphalt and chipsealed. This "test"

I believe the future is bright for all road and highway departments despite the present economic situation and especially for our organization as we continue to expand and share new ideas.

will be shared next year to give the membership an idea of how well it worked for us.

We will have two more member counties to add to the NWPMA from Idaho. These counties have adopted the MTC, Metropolitan Transportation Commission Pavement Management program and we have helped them to set up their pavement inspection sections. The more members we can bring to the organization, the stronger we become in helping others improve or enhance their systems.

I believe the future is bright for all road and highway departments despite the present economic situation and especially for our organization as we continue to expand and share new ideas. I know we, as highway and road maintenance departments, are the key to the success of commerce in our respective states and communities. The 21st century holds the promise of new and exciting innovations and ideas and we are the ones that will make those ideas work.

Thank you for a great ride.

George Alton,
Chairman NWPMA



Intersection Safety Facts

This year, National Stop on Red Week was held on Sept. 7-13, 2002. The Insurance Institute for Highway Safety released intersection safety facts, which excerpted results of studies by the Federal Highway Administration; the National Highway Traffic Safety Administration; the Insurance Institute for Highway Safety; and Louis Harris Poll, Advocates for Highway and Auto Safety during the years 1999-2002.

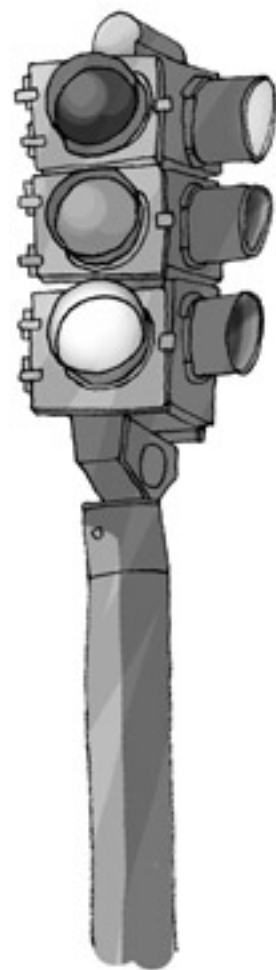

- Each year, more than 1.8 million intersection crashes occur throughout the nation. Of those, more than 200,000 are due to red light running. At least 850 people are killed. More than 100,000 of red light running crashes result in injury.
- Forty percent (40%) of all pedestrian deaths involving vehicles other than large trucks occurred at intersections.
- In 2000, there were more than 8,400 fatal "intersection" or "intersection-related" crashes nationwide. This accounts for approximately one of every five fatal crashes on our roads.
- In urban areas, 50% of all crashes occur at intersections.
- More than 50% of rear end crashes, the majority of which occur when a trailing vehicle strikes a lead vehicle that is either stopping or has come to a stop, occur at or near intersections.

■ An overwhelming three-fourths (78%) of the American public believe more attention should be paid to making dangerous intersections safer for drivers. An even higher number - 80% - think they need to be made safer for pedestrians.

- According to a survey conducted by the U.S. Department of Transportation and the American Trauma Society, 63% of Americans see someone running a red light at least a few times a week and, at most, once a day. One in three Americans knows someone who has been injured or killed by a red-light runner.
- Far fewer crashes occur at intersections with roundabouts than at intersections with signals or stop signs. A study conducted in Maine of 24 intersections before and after the construction of roundabouts showed a 39% overall decrease in crashes and a 76% decrease in injury producing crashes. Collisions involving fatal or incapacitating injuries fell by almost 90%. (IIHS, 2000)
- Elderly pedestrians are particularly at risk for injury or death at intersections. Thirty-six percent (36%) of pedestrian deaths among people age 65 and older in 1999 occurred at intersections. Many intersections permit pedestrian crossing, yet have signals timed to provide for the maximum movement of vehicles, not pedestrian traffic.
- On average, a pedestrian is killed every 111 minutes in the U.S. ▲

Making Work Zones Work for You

Reprinted from Focus, August 2002

The North Carolina Department of Transportation (DOT) and the Federal Highway Administration (FHWA) teamed up recently with the goal of "Making Work Zones Work Better." At a pilot work zone mobility and safety workshop held in Raleigh, North Carolina, in June 2002, 115 participants heard presentations on such topics as worker safety, work zone strategies, traffic management, contracting, and travel information. The event served as the pilot for a series of work zone workshops that will be held around the country over the next 18 months.

"The first one out of the gate is always the most difficult, but we thought it went really well," says Jimmy Travis of North Carolina DOT and a member of the Federal/State team guiding the workshop series. "We had a good cross-section of participants-About 75 percent from North Carolina DOT, 15 percent from utilities and construction, and the rest coming from the North Carolina State Highway Patrol and Department of Motor Vehicles. Everyone was really receptive and open to the new ideas."

The workshop series is part of a nationwide effort on the part of FHWA to promote new technologies, practices, and products that will enhance mobility and safety in highway work zones. In addition to providing lectures by experts in the field, the workshops will feature open forums and other activities where State highway officials can share ideas that have worked for them. State police representatives are also encouraged



The workshop series is part of a nationwide effort on the part of FHWA to promote new technologies, practices, and products that will enhance mobility and safety in highway work zones.

to participate, as law enforcement is key to making work zones operate effectively.

"Making Work Zones Work Better" is not just a slogan, but a vital necessity. One thousand and twenty-six persons were killed in work zones in the United States in 2000, with drivers and passengers accounting for roughly 84 percent of that total. "Traffic is growing, congestion is growing, and there are more work zones set up during the repair of

our aging highways.

More work zones plus more congestion equals more delay and more driver frustration. We need to maximize availability and minimize user impacts. It's more important than ever that our approach to work zones be studied and improved upon," says FHWA's Marianna Rizzo. "There's a common misconception that it's the workers who are most often injured or killed in work zones, but the National Highway Traffic Safety Administration's Fatality Analysis Reporting System statistics show it's really the driving public."

Mobility and safety are not the only important work zone issues covered in the workshop: Lower user costs, better planning and management of corridors, and better traffic management are among the benefits States can receive through improving work zones.

The North Carolina workshop featured such topics as "Making Work Zones More Enforcement Friendly" and "Innovative Traffic Control Devices for Improving Safety at Rural Work Zones." A presentation on the "Dynamic Late Merge Concept" described how this new concept integrates conventional lane closure merge control with the late merge approach, which is designed to encourage drivers to remain in their lanes until the merge point at the lane closure taper. This integration is based on real-time measurements of traffic conditions in advance of the lane closure. Also featured was a case study of the \$26 million rehabilitation of the McClugage Bridge in Illinois, which relied on a combination of

moveable barrier and interactive traffic management systems to reduce traffic delays. The barrier was moved twice daily to provide two lanes of travel in the direction of peak hour traffic flow. Meanwhile, the portable traffic management system supplied motorists with real-time delay information and suggested alternate routes when backups occurred.

“More work zones plus more congestion equals more delay and more driver frustration. We need to maximize availability and minimize user impacts.”

Presenters also assessed new technologies and contracting techniques, including the Wizard CB Alert System, which uses a CB radio transmitter to alert CB users that they are approaching a work zone with a lane closure; intrusion devices that alert workers that a vehicle has penetrated the work zone; and outcome-based contracting procedures, including A+B contracting, lane rental, warranties, and design/build.

After each session, participants had the opportunity to provide feedback, reveal the barriers and challenges they've experienced in implementing certain work zone methods, and talk about other approaches that have been effective for them in the past. “We've found that workshop participants prefer shorter presenta-

tions and more discussion time, since that's when they really exchange the most valuable information,” says Travis. North Carolina DOT plans to use its experience in coordinating the workshop to help guide other States who will host future workshops.

Following the successful pilot in North Carolina, the workshop series will officially kick off with a September 26, 2002, event in College Park, Maryland, hosted by the Maryland State Highway Administration.

For registration details on the next workshop or for more information on the “Making Work Zones Work Better” program, to find out about hosting a workshop in your State, or to obtain a CD-ROM copy of the FHWA work zone research compendium (see May 2002 Focus), contact Marianna Rizzo at FHWA, 202-366-9631 (email: marianna.rizzo@fhwa.dot.gov). For more information on the North Carolina workshop, contact Jimmy Travis at North Carolina DOT, 919-733-2210 (email: jtravis@dot.state.nc.us).

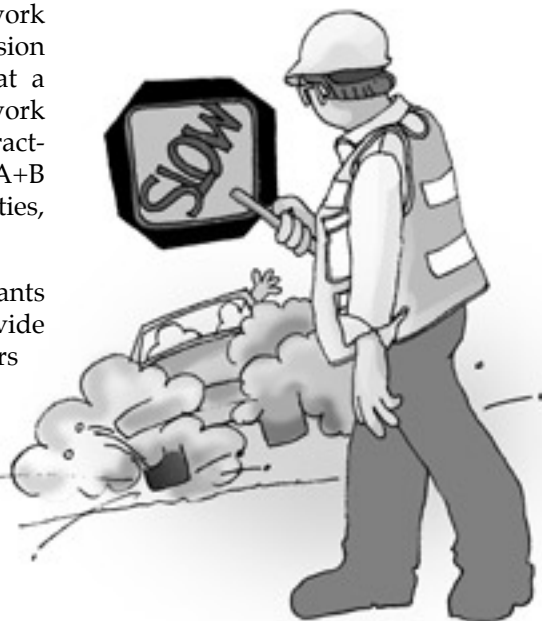

THE MANUAL ON UNIFORM TRAFFIC CONTROL DEVICES (MUTCD)



Federal Register published the revision of the MUTCD regarding Accessible Pedestrian Signals as an interim rule on July 30, 2002. The final rule was effective on August 29, 2002.

New NHTSA Study Shows Economic Impact of U.S. Motor Vehicle Crashes Reaches \$230.6 Billion

U.S. Transportation Secretary Norman Y. Mineta announced that the economic impact of motor vehicle crashes on America's roadways has reached \$230.6 billion a year, or an average of \$820 for every person living in the United States. His announcement was based on a comprehensive new research study released by the U.S. Department of Transportation's National Highway Traffic Safety Administration (NHTSA).

The new report, based on calendar year 2000 data, calculates the U.S. economic costs of an average roadway fatality at \$977,000 and estimates the economic costs associated with a critically injured crash survivor at \$1.1 million.

“This new report offers further proof of the enormous toll America faces each year due to death and injury on our roadways. It underscores the compelling need for all of us - individuals as well as government - to strengthen our commitment to highway safety,” said Secretary Mineta.

NHTSA's new study, titled “The Economic Impact of Motor Vehicle Crashes 2000”, highlights the vital importance of seat belt use.

In one year, the use of seat belts prevents an estimated 11,900 fatalities and 325,000 serious injuries, saving \$50 billion in medical care, lost productivity and other injury related costs. Conversely, the failure of crash victims to wear seat belts leads to

In one year, the use of seat belts prevents an estimated 11,900 fatalities and 325,000 serious injuries, saving \$50 billion in medical care, lost productivity and other injury related costs.

fatalities and 143,000 needless injuries, costing society \$26 billion.

“The evidence is overwhelming that seat belts save lives and reduce the severity of injuries. This report makes it obvious why we must buckle up and why we must dedicate ourselves to a higher seat belt use rate,” said Dr. Jeffrey W. Runge, NHTSA Administrator.

The report underscores the huge economic costs associated with alcohol-involved crashes, which resulted in an estimated 16,792 fatalities in 2000, as well as 513,000 nonfatal injuries, and \$50.9 billion in economic costs. Such crashes account for 22 percent of all crash costs.

Costs for crashes involving a driver or non-occupant with a blood alcohol content of .10 percent or greater accounted for 75 percent of the total of all alcohol-involved crash costs. The impact of alcohol involvement increases with injury severity. Crashes linked to alcohol accounted for 46 percent of fatal injury crash costs; 21 percent of nonfatal crash costs; and 10 percent of the costs in crashes involving property damage only.

The study determined that excessive driving speed is associated annually with 12,350 fatalities and 690,000 non-fatal injuries. This represents 30 percent of all fatalities and 13 percent of all nonfatal injuries. Crashes in which at least one driver was exceeding the legal speed limit or driving too fast for conditions cost \$40.4 billion in 2000, or \$144 for every person living in the U.S.

The NHTSA study also estimates the yearly economic cost of roadway crashes to include:

- \$61 billion in lost workplace productivity.
- \$20.2 billion in lost household productivity.
- \$59 billion in property damage.
- \$32.6 billion in medical costs.
- \$25.6 billion in travel delay costs.

About 9 percent of costs from motor vehicle crashes are paid from public revenues. Federal revenues

WSDOT Library Your info link

account for 6 percent, while states and localities pay about 3 percent. Private insurers pay about 50 percent. Individual crash victims pay about 26 percent. Third parties, such as charities, health care providers and uninvolved motorists delayed in traffic, pay about 14 percent.

Overall, nearly 75 percent of the costs of roadway crashes are paid by those not directly involved - primarily through insurance premiums, taxes and travel delay. In 2000 these costs, borne by society rather than individual crash victims, totaled \$170 billion.

All told, the cost of motor vehicle crashes in the U.S. has reached 2.3 percent of the U.S. Gross Domestic Product (GDP).

In the year 2000, which the NHTSA research used as a basis for determining the annual economic impact of motor vehicle crashes, 41,821 persons were killed; 5.3 million were injured, and 27.6 million vehicles were damaged.

The new study is available on NHTSA's website at: <http://www.nhtsa.dot.gov/>

In the WST2 newsletter Issue 73, Winter 2002, the WSDOT Library column was on "Transportation Security." In the aftermath of 9/11, there have been many articles, reports, books, etc. written regarding the security of America's infrastructure and how to guard against possible future terrorists attacks. The following is a partial listing of materials in both the WSDOT Library and the Washington State Library collections. Your local public library or university/college library may also have these materials available for your use.

- Chemical safety: emergency response community view on the adequacy of federally required chemical information. U.S. General Accounting Office, July 2002. GA 1.13:GAO-02-799 Web site: <http://www.gao.gov/new.items/d02799.pdf>
- Critical infrastructure protection: federal efforts require a more coordinated and comprehensive approach for protecting information systems. U.S. General Accounting Office, July 2002. GA 1.13:GAO-02-474 Web site: <http://www.gao.gov/new.items/d02474.pdf>

- The local role in homeland security, hearing before the Committee on Government Affairs, U.S. Senate, December 11, 2001. Y 4.G 74/9: S.HRG.107-310 Web site: http://www.senate.gov/~gov_affairs/hearings01.htm
- Policing the borders: can the United States guard against terrorists? CQ Researcher, February 22, 2002, 12(7) pp. 145-168.
- Protecting public surface transportation against terrorism and serious crime: continuing research on best security practices. Mineta Transportation Institute, 2001.
- Public transportation security: Volume 1, Communication of threats: a guide. Transportation Research Board, 2002. TCRP Report 86.
- U.S. Energy security: options to decrease petroleum use in the transportation sector, hearing before the Subcommittee on Energy, Committee on Science, U.S. House of Representatives, November 1, 2001. Y 4.SCI 2: 107-43

If you'd like help obtaining copies of these publications, please contact Jennifer Boteler, WSDOT Librarian, at (360) 705-7751 or Botel@wsdot.wa.gov



By Roger Chappell, WST2 Technology Integration Engineer, WST2 Center

Global Positioning System (GPS) Offset Devices: More Tools for the Toolbox

In the last issue, I wrote about the invisible forces that affect GPS signals, forces like multipath, Position Dilution Of Precision (PDOP), and urban canyons. In this issue, I will focus on offsets and offset devices.

What is an offset? In its simplest definition, an offset is the identification of an unknown location from a known location. Whether you use a laser rangefinder or a manual system, like a rag tape and a compass, the objective is still to locate something at an unknown location from a known GPS point or location. Many people think of an offset as simply a distance and a direction on the compass. This is sufficient if you are only concerned with horizontal coordinates (X&Y or 2D space). If you also require elevation (Z or 3D space), then a little more information will be necessary. In order to compute the difference in elevation between your GPS and the object of interest, you will need to know the inclination at which the distance measurement was made. For example, in addition to the compass bearing, the offset could be described in terms of a horizontal distance and a vertical distance, or slope distance and an



inclination. If you don't want to do impromptu manual trigonometry to convert a slope distance into horizontal and vertical components, you will want to integrate an offset device (such as a laser rangefinder) into your data collection system.

Many laser range-finding systems can input a bearing, distance and inclination automatically into a GPS system. The offset created by a laser rangefinder is a point. For example, from a point or GPS location, the measurement of the offset

is the bearing, distance and inclination of the targeted point. In a fully integrated GPS/offset device system, the offset measurements will be automatically computed.

There are other types of features besides a point that you may want to create using an offset. Whether you want to avoid hacking your

way centerline, you could measure the distance from the edge of the pavement to the centerline (which is the offset) then create the line by walking down the edge of the road. Such an offset might be described as 15 feet to the left of the line (road). The final line can then be added at the proper location when the data is processed back in the office.

obstruction (tree canopy) or where either buildings or terrain blocks the line of sight to the satellites. Additionally, a GPS receiver is designed to compute the location of its antenna. This means that in order to capture the location of an object, the operator is physically required to go to the location of the

Z value (Height) is six feet above the ground. This is important to keep in mind especially when using offset devices, because the offset measurement is also based on the center of the GPS antenna. When using a laser rangefinder, it is important to note that the offset of the object will be measured from the optical center of the laser rangefinder in combination with the GPS antenna. After it has been measured, the offset will be applied to the GPS antenna's location. If the laser rangefinder and the GPS measurements are not made at the same location, you will introduce error. For higher accuracy work, you will need a convenient way (such as a mono or tripod) to hold the GPS antenna and the laser rangefinder near the same position. It may be obvious, but you will also need to remember that placing the laser on top of the antenna will block the GPS satellite signals. I have also seen people with a backpack GPS unit hold out a laser to take an offset measurement and the laser is over a meter away from the antenna. This may be adequate precision for the data being collected, but should be accounted for in the final solution of that GPS location. Many data collectors provide a GPS location (X,Y&Z) then use an offset device to calculate a bearing and distance to a target location. Along with procedures used to operate the equipment consistently, each component in the system is capable of some level of accuracy that should be identified and accounted for in the final solution.

So let's look at a laser range-finding system. Laser range-finding systems come in all shapes and sizes, from fancy binoculars to units that look like a radar gun. Some of them will only measure a distance from point to point, while others are sophisticated systems that are fully integrated into GPS data collection systems. Basically, what most people refer to as a laser rangefinder consists of several in-

Users should be aware that the compass in a laser rangefinder adheres to the same magnetic principles as a manual magnetic compass.

tegrated systems: a laser reflection system, a compass, and possibly single or dual axis clinometers. All these hardware sensors are then integrated using a micro PC and software and typically have some type of user interface and impute device.

Lasers

The laser provides a pulse of light and then measures how long it takes that pulse to bounce off an object and return to the laser unit. The range is half the distance from the optical center of the laser to an object and back, at the speed of light. It works very similar to a radar detector, which could also be used as a type of offset device.

Compasses

Next, a compass provides an azimuth (a horizontal angle measured clockwise from a known point). The starting point for a digital compass is the same as a manual compass (north). If you are using this as an integrated system with a GPS unit, make sure both systems are using the same "north" as a starting point. The Earth's magnetic pole is not in the same location as the Earth's rotational axis; the rotational axis is defined as true north. This difference is known as the magnetic declination. True and magnetic north can vary from one another by as much as tens of degrees.

Clinometers

Clinometers provide measurements in vertical degrees relative to a level horizontal plane. Clinometers are what allow you to capture a height or slope measurement.

The micro PC board's input keypads and software convert information from these hardware sensors into data usable for humans. How fast a laser pulse can return from an object is only important if you can convert that measurement into feet or meters.

Precision vs. Accuracy

It is possible to do something precisely and repeatedly, but still obtain inaccurate results. It is important to practice with your equipment and test it on known points before any field data collection operations. The first test is to hit the same target consistently. As with any target practice, the farther and smaller the target, the harder it will be to hit it consistently. You will also find the more reflective the target the better your return pulse will be. There is also what is known as laser skip. Laser skip is where the pulse actually skips off a surface, due to angle or because the surface is wet and highly reflective, and the return pulse is coming back from something other than the intended target. That is why testing with targets at known locations is so important. You will also want to test the accuracy of your system. First, your GPS unit has some level of accuracy, for example, you are using a D (differential) GPS and your GPS unit is producing submeter results. Next, the footprint of the beam or pulse of your laser is some given size at so many meters; for example, the footprint is six inches at thirty meters. Next, how accurate is your compass and clinometers? For example, suppose you are using a laser that can accurately measure distance to 6000 meters and a compass that is accurate to 0.5 degrees. Even when you have a perfectly

Offset devices also work well when it would be difficult to receive signals from satellites due to an obstruction (tree canopy) or where either buildings or terrain blocks the line of sight to the satellites.

object being cataloged. Offset devices work when it is not always practical to physically visit the location of every object you wish to map. Also, using offsets can help reduce time traveling from location to location, which increases field data collection productivity. Using offset devices can allow a user to stay at one location and record the offsets and attributes of many objects, this is known as data mining.

The GPS antenna is an important part of your GPS system since this is where the signals from the satellites enter the system; it is the location of the computed GPS location (X,Y&Z). If the antenna is six feet above the ground, then the



way through a wetland or walking down the centerline of a busy highway, most mapping grade GPS systems today will allow you to enter a constant or variable offset distance to the data that you are collecting. In the example of a road-

Using offsets and offset devices are handy when it would be difficult to place your antenna over the object that you are trying to catalog.

Offset devices also work well when it would be difficult to receive signals from satellites due to an



Experienced laser rangefinder users will often take several shots at each object simply to confirm that they get about the same answer on a consistent basis. This is usually not an inconvenience since it takes only a second or so for a laser range measurement.

Users should be aware that the compass in a laser rangefinder adheres to the same magnetic principles as a manual magnetic compass. Therefore, if the compass in the rangefinder is held too near an object that contains ferrous metals, the compass will be magnetically influenced and will provide an incorrect reading. One of the most common rogue influences on a compass in the field is the automobile of the user. However, other magnetically influential materials can be much more subtle, such as the steel reinforcement hidden within concrete (especially bridges). The potential problem of magnetic corruption is usually quite easy to avoid in the field as long as the user is aware of the issue and is paying attention.

Another potential error can occur if the user pushes a ranging device beyond reasonable limits. As stated earlier in this article, if you use a laser rangefinder that accurately measures distance to 6000 meters and a compass that is accurate to 0.5 degrees, the compass will limit the accuracy of your results. There is a direct relationship between the accuracy of your offset position and the accuracy of your compass. The longer the offset distance, the more compass errors are accentuated. Many rangefinders with compasses on the market today have a specified accuracy of only a fraction of a degree. The maximum range of a laser system can be much farther than the angle that the compass can account for.

The entry of offset distance and direction information can either be estimated by the user or obtained more accurately from a hand-held

ranging device. The most fundamental aspect of such a system is what or who supplied the offset data. With an integrated GPS and a rangefinder, you can simply pull the trigger on the rangefinder and the offset distance and direction are automatically transferred to the GPS unit and applied to the GPS position. In an integrated system, when the user views the location of an object, the correct, shifted position is displayed (computed by combining the original GPS position with the offset).

In an un-integrated system, the GPS unit is not capable of accepting offsets digitally. Therefore the offset details are manually entered via the keyboard. The user obtains an offset through any means available (perhaps even from a measuring tape and compass) then manually types in the distance and bearing into the GPS data collector. With

a manual system there are risks of data entry errors. On the other hand, if the laser is being used not for an offset but rather to compute and output the volume of a stockpile, it is likely that the user would prefer to store the computation as an attribute of the stockpile (not as an offset).

Does your system have versatility in output? After an offset has been stored, how can it be expressed or used? Make certain that the offset data is utilized in all parts of the post-processing software. For example, when you view the features graphically in the form of a map, are the offsets applied? That is, do the features appear at the GPS locations or at their offset locations? Additionally, can the actual offset values be viewed via a simple query? Does the data export directly to a GIS (Geographic Information System) or CAD (Computer-Aided

Drafting) format? You should also have the choice to view, output, export, display, plot, or print your GPS positions either with or without the offsets having been applied.

It is important to examine any system from the beginning to the end, looking at the entire process from the moment the first measurement is taken to the end product. Try to ensure that in all steps along the way there are no missing pieces. To optimize usability, ensure that the systems you are considering are practical for the types of data that you are collecting and the environments in which you are working.



clear day and a reflective target, the compass will limit the accuracy of your results. You need to be aware that 0.5 degrees of compass error can cause nearly 1 meter of error when projected to a target only 100 meters away. Your business needs will determine how accurate your data needs to be. Testing will give you confidence that you are consistently achieving some stated level of accuracy.

Tips and tricks for offset devices

The most common error source when combining laser rangefinders and GPS is compass error. The range measurement of a laser is generally quite dependable, even

when shooting at a non-reflective target. There are several errors that commonly occur in the field when using any type of compass. They are generally not a serious problem as long as the user is aware of them and pays attention to the collection procedures and equipment. When using any type of compass, it is important that you give the compass a little time to settle to a stable value. Perhaps the most common error occurs when a user lifts the compass and attempts to read a value while the needle is still fluctuating within a few degrees of the correct bearing. Unfortunately with most laser rangefinders there is no needle to watch, like on a handheld compass, to see when it stops moving.



Free Publications from Your WST2 Center

For Washington residents only due to limited quantities.

Name	Agency		
Mailing Address	City	State	Zip+4
Phone	Fax	E-mail	

This order form is available on the WSDOT Homepage at:

<http://www.wsdot.wa.gov/TA/T2Center/T2PUBS.htm>

Fax, e-mail, phone, or mail your order to:

Fax: (360) 705-6858; E-mail: WST2Center@wsdot.wa.gov; Phone: (360) 705-7386;

Mail: WST2/WSDOT, H&LP, P.O. Box 47390, Olympia, WA 98504-7390.

✓ Check the items you would like to order. An asterisk (*) denotes publications included in the 2002 WST2 CD Library.

■ 1999 Audio Visual Catalog, T2Center

■ WST2 Technology Transfer CD Library: Technical Documents, 2002

■ Asphalt Pavement Repair Manuals of Practice, SHRP, 1993*

■ Asset Management Primer, FHWA, 1999

■ A Walkable Community is More Than Just Sidewalks, FHWA, 2000

■ Bicycle & Pedestrian Case Studies: No. 7: Transportation Potential & Other Benefits of Off-Road Bicycle & Pedestrian Facilities, FHWA, 1992 No. 14: Benefits of Bicycling and Walking to Health, FHWA, 1993 No. 15: Environmental Benefits of Bicycling & Walking, FHWA, 1993

■ Concrete Pavement Repair Manuals of Practice, SHRP, 1993*

■ Concrete PASER Manual, University of Wisconsin, 1998

■ Contracting for Professional Services in Washington State, MRSC, 1994

■ Crack Seal Application, FHWA, 2001

■ Data Integration Primer, FHWA, 2001

■ Designing Sidewalks and Trails for Access: Best Practices Design Guide, Part 2, FHWA, 2001

■ Dust Control on Low Volume Roads, FHWA, 2001

■ Dust Palliative Selection and Application Guide, USFS, 1999*

■ Engineer's Pothole Repair Guide, US Army Corps of Engineers, CRREL, 1984

■ Family Emergency Preparedness Plan, American Red Cross, et al., 1998

■ Field Guide for Unpaved Rural Roads, Wyoming T2 Center, 1997

■ Fish Passage Through Culverts, FHWA, USDA, 1998

■ General Field Reference Guide (Pocket Size), 2002

■ Geotextile Selection and Installation Manual for Rural Unpaved Roads, FHWA - 1989

■ Getting People Walking: Municipal Strategies to Increase Pedestrian Travel, Rhys Roth, Energy Outreach Center

■ Gravel Roads – Maintenance and Design Manual, SD LTAP, 2000*

■ A Guide to the Federal-Aid Highway Emergency Relief Program, USDOT, June 1995

■ Local Agency Pavement Management Application Guide, WST2 Center, 1997*

■ A Guide for Local Agency Pavement Managers, NWT2 Center, 1994*

■ A Guide for Erecting Mailboxes on Highways, AASHTO, 1984

■ Highway/Utility Guide, FHWA 1993

■ Improving Conditions for Bicycling and Walking, FHWA, 1998

■ Improving Highway Safety at Bridges on Local Roads and Streets, FHWA, 1998

■ International State-of-the-Art Colloquium on Low-Temperature Asphalt Pavement Cracking, CRREL, 1991

■ Local Agency Safety Management System, WSDOT, 1998, Reprinted 2000*

■ Local Low Volume Roads and Streets, ASCE, 1992

■ Maintenance of Aggregate and Earth Roads, WST2 Center (1994 reprint)

■ Maintenance of Signs & Sign Supports for Local Roads and Streets, FHWA, 2001

■ Manual of Practice for an Effective Anti-icing Program: A Guide for Highway Winter Maintenance Personnel, FHWA, 1996*

■ New Generation of Snow and Ice Control, FHWA

■ Pavement Surface Condition Field Rating Manual for Asphalt Pavement, NWPMA, WSDOT, 1999*

■ Pedestrian Facilities Guidebook, WSDOT, 1997

■ Planning & Implementing Pedestrian Facilities in Suburban and Developing Rural Areas, TRB

■ Pothole Primer – A Public Administrator's Guide, CRREL, 1989

■ Recommendations to Reduce Pedestrian Collisions, WSDOT, December 1999

■ Redevelopment for Livable Communities, Rhys Roth, Energy Outreach Center, 1995

■ Signposts for Snow Trails, USDA, 1998

■ State-of-the-Art Survey of Flexible Pavement Crack Sealing Procedures in the United States, CRREL, 1992

■ Streetwise, A Simplified Local Agency Pavement Management System, WSDOT, 2000*

■ Superpave System – New Tools for Designing and Building More Durable Asphalt Pavements, FHWA

■ Traffic Calming: A Guide to Street Sharing, Michael J. Wallwork, PE, 1993

■ Trail Construction & Maintenance Notebook, USDA, 2000

■ Utility Cuts in Paved Roads, Field Guide, FHWA, 1997

■ W-Beam Guardrail Repair and Maintenance, FHWA, 1996

■ Washington Bicycle Map, WSDOT, 2001

■ Wetland Trail Design and Construction, USDA, 2001

■ Wildlife Habitat Connectivity Across European Highways, FHWA, 2002

Workbooks and Handouts from WST2 Center Workshops:

■ Application of Geographic Information Systems for Transportation, FHWA, 1999

■ Construction Documentation: Construction Training Manual for Local Agencies, WSDOT, 2002

■ Design, Construction and Maintenance of Highway Safety Features and Appurtenances, FHWA, 1997 (update included)

■ Handbook for Walkable Communities, by Dan Burden and Michael Wallwork

■ Highway Maintenance Welding Techniques and Applications, Tom Cook, Cornell Local Roads Program, 1995

■ Pavement Maintenance Effectiveness/ Innovative Materials Workshop Participant's Handbook

■ Snow & Ice Control Chemicals, Theory & Practice, Dale G. Keep, Ice & Snow Technologies, LLC,

Videotapes:

■ Walkable Communities: Designing for Pedestrians, Dan Burden, \$50/set of 4 videotapes

CD ROM:

■ Gravel Roads: Maintenance and Design Manual, SD LTAP, 2000*

■ Intelligent Transportation Systems Awareness, FHWA, 1999

■ Pedestrian/Bicycle Crash Analysis Tool, FHWA, 1999

■ Pedestrian/Bicycle Safety Resource Set, FHWA, 2000

■ Pavement Preservation: State of the Practice, FHWA, July 2000

■ Rockfall Catchment Area Design Guide, ODOT, 2002*

■ WST2 Technology Transfer CD Library Technical Documents, 2002

■ *Denotes publications included in 2002 WST2 Technology Transfer CD

Library: Technical Documents

Non-Credit Self-Study Guides:

■ These non-credit WSDOT self-study guides may be obtained from the WST2 Center. An invoice will be sent with the books.

■ Basic Surveying, \$20

■ Advanced Surveying (metric), \$20

■ Contract Plans Reading, \$25

■ Technical Mathematics I, \$20

■ Technical Mathematics II, \$20

■ Basic Metric System, \$20

H&LP Online Publications & Information:

City Streets as part of State Highways \\trout\www\wsdot\TA\Operations\LAG\CityStreets.html

Environmental Procedures Manual (M31-11) <http://www.wsdot.wa.gov/eesc/environmental/programs/regcomp/ProceduresManual/start.pdf>

Local Agency Guidelines and Updates <http://www.wsdot.wa.gov/TA/Operations/LAG/LAGHP.htm>

Federal Aid Progress Billing Form <http://www.wsdot.wa.gov/TA/ProgMgt/Projectinfo/BILLFORM.XLS>

State Funded Progress Billing Form <http://www.wsdot.wa.gov/TA/ProgMgt/Projectinfo/BILLFORMSTATE.xls>

STIP (State Transportation Improvement Program) <http://www.wsdot.wa.gov/TA/ProgMgt/STIP/STIPHP.htm>

TIP (Local Agency 6-Year Transportation Improvement Program) <http://www.wsdot.wa.gov/TA/ProgMgt/STIP/TIP.html>

Bicycle maps, guidelines, trails, research <http://www.wsdot.wa.gov/TA/PAandI/PAIHP.html>

Pedestrians/ project funding sources, research, trails <http://www.wsdot.wa.gov/TA/PAandI/PAIHP.html>

Heritage Corridors/ grants, Scenic Byways, funding sources <http://www.wsdot.wa.gov/TA/PAandI/PAIHP.html>

Pavement Publications & NWPMA links <http://www.wsdot.wa.gov/>

TA/T2Center/Mgt.Systems/PavementTechnology

Links to Training and Other Valuable Resources

Get on one of our e-mail communication "List-serves" <http://www.wsdot.wa.gov/TA/T2Center/T2HP.htm>

Safety Management Publications & Information <http://www.wsdot.wa.gov/TA/T2Center/Mgt.Systems/SafetyTechnology/>

Register Online for WST2 Classes & Other Information <http://www.wsdot.wa.gov/TA/T2Center/T2HP.htm>

Local Agency folks in Washington State are invited to bring their inventions to the next PNTTE in 2003. <http://www.wsdot.wa.gov/ta/T2Center/TechnoExpo/MouseTraps.html>

Retired Professional Program <http://www.wsdot.wa.gov/TA/T2Center/Retired.htm>

Student Referral Program-Engineering students are hired by local agency public works departments for "Hands-on" summer experience <http://www.wsdot.wa.gov/TA/T2Center/SRS.htm>

Computer Programs

The following computer programs may be downloaded from the Internet at: www.wsdot.wa.gov/fossc/mats/Apps/EPG.htm:

Everseries Pavement Analysis Programs: This series of programs contains three independent modules:

1. Evercalc 5.0 – A FWD Pavement Moduli Backcalculation Program
2. Everstress 5.0 – A Layered Elastic Analysis Program
3. Everpave 5.0 – A Flexible Pavement Overlay Design Program

Important: These programs are updated regularly. Please send your e-mail address to sivanen@wsdot.wa.gov to be included in the mailing list for updates.

FWD Area Program - This program is useful in calculating Normalized Deflections Area Value, and Subgrade Moduli from FWD Data. The program is available for download at www.wsdot.wa.gov/fossc/mats/pavement/fwd.htm



Laurel Gray, WST2
Training Program
Coordinator

Washington State T2 Center

Contact: Laurel Gray (360) 705-7355
Wendy Schmidt (360) 705-7386
<http://www.wsdot.wa.gov/TA/T2Center/train2.htm>

To register for a class in this section, use the contact listed above.

The class fees shown apply to both public and private sector students.

Classes marked with an asterisk (*) are part of the Road and Street Management Training Program and fulfill a portion of the core requirements needed for the Certificate of Achievement in Road Management.

Introduction to GPS Mapping Grade Equipment

Sessions can be scheduled upon request and in an individual agency. \$325. Instructors: Max Schade and Heath Bright, WSDOT. This is an introductory course on mapping grade GPS equipment and is taught by Trimble-certified instructors. It is designed to provide basic knowledge and skills in the use of GPS technology in mission planning, data gathering, and data processing. The training will enable field operation personnel to use new methods and Trimble mapping grade equipment as well as understand problems encountered when using the GPS satellite constellation.

Fundamentals and Abatement of Highway Traffic Noise

December 10-13, Shoreline. \$400. This is a National Highway Institute course. Seating is limited, early registration advised. The course covers the requirements of 23 CFR Part 772, Procedures for Abatement of Highway Traffic Noise and Construction Noise, and the noise requirements of the National Environmental Policy Act of 1969. Objectives: perform existing noise measurements with a sound level meter, utilize noise

fundamentals to accomplish highway traffic noise prediction, identify highway traffic noise impacts, conduct analyses of noise abatement measures, prepare documentation to fulfill FHWA requirements, and communicate the results of analyses in meetings, correspondence.

Anatomy of a Grant

December 17-18, Tacoma. \$150. In this two-day workshop you'll learn some practical steps to take toward grantwriting and how to approach the right funders for the dollars you need. The class will discuss writing three types of grants: federal, state, and foundations.

Restoration of Aquatic-Species Passage Using Stream Simulation

January 27-31, Tacoma. \$125. The intent of this course is to develop the skills necessary to meet current state and federal standards for aquatic passage. This four-and-a-half day course will focus on the stream simulation method of designing aquatic species passage under roads and highways. The training will use a systematic, five-phase approach to passage design: large-scale analysis, project-level analysis, engineering design, construction and project monitoring.

Bridge Condition Inspection Update (BCIU)

February 4-5, Lacey; February 19-20, Ellensburg. Free. This course provides information on the latest inspection manual, laptop bridge inspections, scour evaluations, bridge file records, and other important bridge inspection issues. Discussions will include: scour evaluations, load ratings, bridge file records, sufficiency ratings and proper coding of bridge elements.

Bridge Condition Inspection Fundamentals (BCIF)

February 11-13, Lacey. Free to local agencies, \$150 to out of state. This training is intended to provide engineering or design technicians and other personnel, who have little or no background in bridges, a basic knowledge of bridges and bridge inspection skills. The course is preparatory for the Bridge Condition Inspection Training (BCIT two week class).

Bridge Condition Inspection Training (BCIT)

March 3-7 and March 10-14, Lacey. Free to local agencies, \$150 to out of state. This two-week course is based on the "Bridge Inspector's Training Manual 90" and will provide extensive training on the condition inspection of in-service bridges. Training includes 20 hours in the field. Satisfactory completion of this course will fulfill the training requirements of the National Bridge

Inspection Standards (NBIS) for a "comprehensive training course" based on the manual. Six CEUs will be awarded.

Pavement Condition Rating Workshop*

May 6-7, Ellensburg; September 9-10, Tacoma. \$45.

Instructor: Bob Brooks. Participants will learn to rate any of the pavements commonly found in Washington. The rating values obtained using the definitions and methods learned in this course should compare favorably with those obtained and used in the Washington State Pavement Management System. Each participant should be able to perform a pavement condition survey with reasonable objectivity.

Classes scheduled for 2003

- Basics of a Good Gravel Road, 4 sessions, April/May. \$35.
- Anatomy of a Grant: Grantwriting, 4 sessions, summer/fall. \$150.
- Roundabout Training, 2 sessions, early spring.
- Bike/Ped: Intersection Design, 1 session, spring.
- Bike/Ped: Trails, 1 session, September.
- Advanced Biological Assessment Preparation, October 16, Olympia.
- Cultural Resources Training, May 6-9, The Dalles, Oregon.

LAG Training

- Construction Documentation – LAG Manual Chapters 51, 52, and 53. 2002-2003 Eleven sessions are scheduled for December 2002 through April 2003. See below for descriptions, dates and locations.
- Consultants – LAG Manual Chapter 31. Curriculum is being developed through the University of Washington/TRANSPEED program. May be ready by Winter 2002.
- Disadvantaged Business Enterprise (DBE)/EEO/OJT – LAG Manual Chapters 26 and 27. Training offered through WSDOT's Office of Equal Opportunity.
- Design Standards from PS&E to Award – LAG Manual Chapters 42-46. T2 offers many PS&E training sessions every year. 2003 schedule to be determined. Four sessions. \$75.
- Emergency Relief Program – LAG Manual Chapter 33. This course is in development.
- Enhancement Program – LAG Manual Chapter 62. Waiting on a new Federal act.
- Environmental/Introduction – LAG Manual Chapter 24. This includes Section 106 Process. Classes to be developed based on interest.
- Funding Workshop – LAG Manual Chapters 12, 21, 22, and 23. Agreements and supplements, prospectus, progress billings. Classes already held. More will be scheduled based on interest.

- Right of Way Procedures – LAG Manual Chapter 25 and the Federal Perspective. Some classes have already been held. More will be scheduled based on interest.
- Roadside Design Guide – Covers the 2002 AASHTO Roadside Design Guide. Curriculum for this new addition to the LAG program is in development.
- LAG Manual Overview – Classes already held. More will be scheduled based on interest.

LAG Courses Now Offered

Construction Documentation: December 4, Vancouver; December 11, Olympia; January 14, North Seattle; January 15, South Seattle; February 11, Olympic Peninsula; February 12, Tacoma; March 11, Spokane; March 12, Moses Lake; March 13, Yakima; April 8, North Seattle; April 9, South Seattle. NO FEE. This course is designed for construction inspectors and those who assist them. The course will provide an overview of the documentation required to ensure compliance with federal regulations in the administration of contracts funded by FHWA and in accordance with the Standard Specifications for Road and Bridges. Six hours of training. Ken Hash of WSDOT's Southwest Region Local Programs instructs the class. Regional Local Programs staff will be in attendance to answer questions.

Two new courses, **Change Orders** (LAG Chapter 52) and **Appraisal Review** (LAG Chapter 25) are being considered for inclusion in the LAG program. If you are interested in these or any of the courses listed above, please let us know by adding your name to the on-line request list at <http://www.wsdot.wa.gov/TA/T2Center/T2hp.htm>. When there are enough people interested in a particular course, a session will be scheduled and you will be notified.

If you have any questions about the LAG Program, call Ron Pate at (360) 705-7383 or e-mail paterd@wsdot.wa.gov.

The Endangered Species Act 4(d) Training Program

The Regional Road Maintenance ESA training is underway. The University of Washington's Transportation Professional Development Program (TRANSPEED) is coordinating and presenting the training program.

Classes have been scheduled and agencies that have committed to the Regional Road Maintenance Program (RRMP) Guidelines by submitting a "Part 3 Application" will be given priority for spots in the classes.

The current series of training tracks are also described below including tuition rates. For program information or course registration, please contact Julie Smith at (206)

543-5539 or by email: jsmith@enr.washington.edu.

The Part 3 Application, which is a commitment to ten program elements (of which the training program is Element #4), can be obtained from the following web site: <http://www.metrokc.gov/roadcon/bmp/pdfguide.htm> or by contacting Janine Johanson at METRO KC (206) 205-7101.

Four ESA Training Tracks

The complete ESA Training Plan has been grouped into four separate tracks: (1) briefing for regional level decision makers, (2) a training course addressing maintenance design and technical staff procedures involved in roadway maintenance activities, (3) a training course addressing field crew practices involved in roadway maintenance activities, and (4) courses to train agency level trainers in training skills applicable to the ESA training program. These trainers are selected by their agencies for this training. Track 4, the trainer training tracks, is divided into two areas: Track 4A will teach individuals instruction skills to teach the engineer and technical staff portion of the program and Track 4B will teach individuals instructional skills to teach the field crew portion.

- Track 1: Briefing for Regional Decision Makers 2 hours. No fee. An overview of the ESA program for regional level management and administration. This is a stand-alone training class and not part of the required training program. Offered by members of the Regional Road Maintenance Forum. Call Roy Harris or Gerry Crum at (425) 257-8800 for information. Information may also be obtained from the web site or by calling Janine Johanson at METRO KC (206) 205-7101.
- Track 2: Introduction, Design and BMP's, Monitoring, and Environmental Roles for Technical and Scientific Staff 2 days. \$225 per person. This course is a combination of the various procedures for technical, professional and environmental staff, supervisors and leads involved in maintenance activities. The tack is an overview addressing: introduction to the Guidelines, design, habitat, ten program elements and maintenance BMP's to meet ESA requirements.
- Track3: Introduction and Outcome-based Road Maintenance 1 day. \$160 per person. This course is a combination of the various procedures for field crews and leads involved in maintenance activities. The track is an overview addressing introduction to the Guidelines, design, habitat, environmental roles, ten program elements and implementation of maintenance BMP's to meet ESA requirements.
- Track 4A: Train-the Trainer for Technical/Scientific Staff 1 day. \$210 per person. For agency-selected ESA trainers. This is the training track to train, evaluate, prepare, and certify candidates to teach the RRMP Track 2.
- Track 4B: Train-the-Trainer for Field Crews and Supervisors 1 day. \$230. For agency-selected ESA trainers. This is the training track to train, evaluate, prepare, and certify candidates to teach the RRMP Track 3.

TRANSPEED University of Washington

Contact: Christy Roop Pack
(206) 543-5539, fax (206) 543-2352
<http://www.engr.washington.edu/epp>

To register for a class in this section, use the contact listed above.

The prices in this section are for local agency/non-local agency.

Pavement Design

December 3-5, Seattle. \$295/495. This course focuses on the critical elements of successful pavement design by covering the basic AASHTO procedures as well as the technical basis for that design procedure. The course is for engineers directly involved in developing or approving pavement structural design alternatives for local agencies as well as state and federal agencies. It covers the development of design concepts in Washington, selection criteria for pavement type, materials, traffic impact, drainage, and other considerations for flexible pavement design. Rigid pavement, rehabilitation design concepts and the use of computers in all phases of pavement design are covered.

Basic Highway Capacity 2000

January 6-8, Lacey. \$295/495. This is the first of two courses in the highway capacity series that combine to provide comprehensive insights into all aspects of capacity and level-of-service analyses for highway, transit, pedestrian, and bicycle facilities. This course will provide participants with a basic understanding of fundamental concepts underlying the analysis methods contained in the 2000 edition of the Highway Capacity Manual. Upon completion of the course, participants should be able to successfully undertake basic facility evaluations, and should also be able to appropriately review and interpret the results of analyses conducted by others.

Winter 2003 Classes

- Roundabout Design Concepts and Guidelines
- Managing Scope, Schedule and Budget
- Traffic Operations
- Basic Roadway Geometric Design
- Stormwater Engineering for Transportation Professionals
- Construction Inspection of Public Works Projects
- Public Works Construction Project Management

Spring 2003 Classes

- Context Sensitive Design
- Advanced Highway Capacity
- Concrete Bridge Design
- Fundamentals of Traffic Engineering
- Scheduling Contract Working Days
- Legal Liability for
- Transportation Professionals

Engineering Professional Programs (EPP) University of Washington

Contact: Emily West
(206) 543-5539, fax (206) 543-2352
<http://www.engr.washington.edu/epp>

To register for a class in this category use the contact listed above.

Drilling and Blasting Techniques for Construction and Quarrying in Seattle

January 13-17, 8 a.m. – 5 p.m. \$1,199 by Dec 30/\$1,299 thereafter. Learn to effectively plan and manage the drilling and blasting project from initial cost estimation to final project evaluation. Special emphasis will be placed on the role project management plays reducing risk and legal liability. This course is ideal for engineers, project managers, blaster, contractors, inspectors and others involved in blasting projects in both the public and private sectors. Taught by two industry leaders, Jerry R. Wallace of Wallace Technical Blasting and John L. Floyd of Blast Dynamics, Inc., and featuring guest speaker Geri Woods of the Department of Labor and Industries of Washington State.

Engineering Refresher Courses

Three evening courses provide thorough preparation for state of Washington engineering examinations.

- E.I.T./Fundamentals of Engineering Exam Review, February 10 – March 19, 2003, Mondays & Wednesdays, 6:30 – 9:00 pm, University of Washington campus, Seattle.
- Mechanical P.E. Exam Review, February 18 – March 27, 2003, Tuesdays & Thursdays, 6:30 – 9:00 pm, University of Washington campus, Seattle.
- Civil P.E. Exam Review, February 25 – April 1, 2003, Tuesdays & Thursdays, 7:00 – 9:30 pm, University of Washington campus, Seattle.

Professional Engineering Practice Liaison (PEPL) University of Washington

Contact: Stephanie Storm
(206) 543-5539, fax (206) 543-2352
<http://www.engr.washington.edu/epp>

To register for a class in this category use the contact listed above.

Winter/Spring 2003 Classes

All classes to be held in Seattle:

- Geology and Geomorphology of Stream Channels
- Writing for Success
- New Technologies and Concepts in Stormwater Treatment
- Low Impact Development Principles and Practices
- Urban Stream Ecology and Restoration

Associated General Contractors of Washington

Contact: Mary Beggs
(206) 284-4500, fax (206) 284-4595
<http://www.agewa.com>

To register for a class in this category use the contact listed above.

Construction Site Erosion and Sediment Control Certification

These WSDOT approved classes are presented by the AGC and available on the following dates: December 2-3, Shoreline; December 11-12, Tacoma; January 8-9, Vancouver; January 22-23, Renton; February 5-6, Everett; February 19-20, Seattle; March 4-5, Wenatchee; March 19-20, Tacoma; April 3-4, Bellingham; April 17-18, Shoreline; May 7-8, Chehalis/Shelton; May 21-22, Renton; June 11-12, Olympia. \$250. Some changes have been made to the training program:

- Recertification requires attendance on Day 1 only, successfully completing exam, and proof of previous WSDOT certification. Recertification cost is \$150. You can check your certification with the on-line database as proof of certification.
- Certification training has been changed from a full two days to one and one-half days. Initial certification is \$250.
- Certification requires successfully completing end of course exam.

Road Builders' Clinic

March 4-6, 2003, Coeur D'Alene, Idaho.

Contact: Kelly Newell at Washington State University
Phone: 1-800-942-4978

2003 Society for Ecological Restoration/Society of Wetland Scientists Joint Regional Conference

March 24-28, 2003, Oregon Convention Center, Portland, Oregon.

Contact: University of Washington Engineering Professional Programs
Phone: (206) 543-5539
<http://www.engr.washington.edu/~uw-epp/>



Red Green Would Love this One!

Pete Davis from the city of Beaverton, Oregon sends us this one. He says "A contractor working for the City of Beaverton tried to take some shortcuts on a traffic calming project but our alert inspectors were not fooled for long!"

Ahhh, duct tape, the universal tool.

Sign of the Times

Do you have a humorous traffic sign to share? Send us a print or e-mail a digital image (preferably a 300 dpi, 1000x1500 dpi jpeg or tiff) and we will add it to our collection for publishing. Please provide your name, title, agency or company, and a short description of where and when you saw the sign. We want to give you credit for your participation.

You can e-mail the image to SundeD@wsdot.wa.gov

Or mail the photo to:
"Sign of the Times"

WST2 Center
PO Box 47390

Please don't send your original photo. Although we will do our best to return the photo, we can't guarantee it.

WASHINGTON STATE T2 STAFF

Daniel L. Sunde, P.E.
WST2 Technology Transfer Engineer
SundeD@wsdot.wa.gov
(360) 705-7390

Roger Chappell
Technology Integration Engineer
ChappeR@wsdot.wa.gov
(360) 705-7539

Laurel Gray
Training Program Coordinator
GrayL@wsdot.wa.gov
(360) 705-7355

Bob Brooks
Pavement Technology Engineer
BrookBo@wsdot.wa.gov
(360) 705-7352

David Sorensen
Traffic Technology Engineer
SorensD@wsdot.wa.gov
(360) 705-7385

Wendy Schmidt
WST2 Training Operations Coordinator
SchmidW@wsdot.wa.gov
(360) 705-7386

John Easley
Road Show Trainer
(360)-705-7386
Fax (360) 705-6858
E-mail
wst2center@wsdot.wa.gov
WST2 Web Site
www.wsdot.wa.gov/TA/T2Center/T2hp.htm

WASHINGTON STATE T2 ADVISORY COMMITTEE

Gary Armstrong
City Administrator
City of Snoqualmie
(425) 888-5337

Phil Barto, Chairman
Maintenance Engineer
Spokane County
(509) 477-7429

Mike Deason
Public Works Director
City of Leavenworth
(509) 548-5275

Randy Hart
Grants Program Engineer
County Road Administration Board
(360) 664-3299

Marjorie Hutchinson
South Zone Engineer
Naches Ranger Station, USFS
(509) 653-2205 ext. 261

Liana Liu
FHWA Highway Engineer
(360) 753-9553

Phil Meyer
Maintenance Coordinator
Whitman County/EWCERS
(509) 397-6206

Craig Olson
Consultant
Olympia
(360) 866-2023

Tom Rountree
Road Maintenance Supervisor
King County DOT/RSD
(206) 296-8196

Jim Seitz
Transportation Specialist
Association of Washington Cities
(360) 753-4137

Richard A. Swan
Colville Business Council/
Washington Tribal Governments
(509) 634-2214
1-888-881-7684 ext. 2214

Dave Zabell
Director of Public Works
City of Bothell
(425) 486-2768

ASSOCIATE MEMBERS

Joe Bonga
Road Construction/Maintenance
Bureau of Indian Affairs
(503) 231-6712

Kathy Lindquist
Research Implementation Manager
WSDOT Research Office
(360) 705-7976

Richard Rolland
Director
NW and Alaska TTAP
rrolland@mail.ewu.edu
(509) 358-2225



Washington State Technology Transfer Center
WSDOT - H&LP Division
P.O. Box 47390
Olympia, WA 98504-7390

PRSR STD
U.S. POSTAGE
PAID
Washington State
Department of Printing