

WST2

Washington State Technology Transfer



Avoid the Pitfalls of Over Documenting on FHWA Funded Local Agency Projects

page **3**

T-Post Adapter for Temporary Signs

page **6**

New Infiltration Pond Design Methods Developed by WSDOT

page **8**



**Washington State
Department of Transportation**

A Technical Digest of the
Washington State Department of Transportation (WSDOT)
and the Local Technical Assistance Program (LTAP)
Issue 86, Spring 2005

Washington State Technology Transfer

WST2 Washington State Technology Transfer

is published quarterly without fee

by WSDOT Highways & Local Programs
Washington State Technology Transfer Center
310 Maple Park Avenue SE
PO Box 47390
Olympia, WA 98504-7390

E-mail: WST2Center@wsdot.wa.gov
Home Page: <http://www.wsdot.wa.gov/TA/T2Center/T2hp.htm>

Requests for subscriptions, change of address, and other subscriber services should be addressed to schmidw@wsdot.wa.gov, or phone (360) 705-7386, or WST2 Center, PO Box 47390, Olympia, WA 98504-7390. Subscriptions are distributed free of charge.

Issue 86, Spring 2005

POSTMASTER:

Please send address changes to WST2,
PO Box 47390, Olympia, WA 98504-7390

Include both old label and new address.



Article contributions, questions, or comments are welcome. Please contact Larry Schofield, P.E., Technology Transfer Engineer, PO Box 47390, Olympia, WA 98504-7390; phone (360) 705-7380, fax (360) 705-6858, or e-mail schofil@wsdot.wa.gov.

Editor reserves the right to refuse to publish and to edit articles to conform to the standards of our publication.

The opinions expressed in articles are not necessarily those of the editor.

Cover photo: *This photo shows the installation of a T-Post Adapter for temporary construction signs.*

Secretary of Transportation

Douglas B. MacDonald

Chief of Staff

Paula Hammond, P.E.

Highways & Local Programs

Director

Kathleen Davis

Engineering Services Manager

Michael Horton, P.E.

Technical Services Manager and

Managing Editor

Brian Walsh, P.E.

Technology Transfer Engineer and

Publishing Editor

Larry Schofield, P.E.

Assistant Editor

Wendy Schmidt

Graphic Design

WSDOT Graphics

Staff Writers

Bob Brooks

Roger Chappell

Laurel Gray

Dave Sorensen

The Local Technical Assistance Program (LTAP) is a national program financed by the Federal Highway Administration (FHWA) and individual state transportation departments. Administered through Technology Transfer (T2) Centers in each state, LTAP bridges the gap between research and practice by translating state-of-the-art technology into practical application for use by local agency transportation personnel.

Any opinions, findings, conclusions, or recommendations presented in this newsletter are those of the authors and do not necessarily reflect the views of WSDOT or FHWA. All references to proprietary items in this publication are not endorsements of any company or product.



Washington State
Department of Transportation



U. S. Department of Transportation
Federal Highway Administration

T echnology News	2
Mayor Unveils Parking Pay Stations; City to Test the Technology for 90 Days	2
A rticles	3
Avoid the Pitfalls of Over Documenting on FHWA Funded Local Agency Projects	3
Jim McManus, Director of Professional Development Programs, UW, Retires	5
M ousetraps	6
T-Post Adapter for Temporary Signs	6
W SDOT Research Office	8
New Infiltration Pond Design Methods Developed by WSDOT	8
G ray Notebook	9
N WPMA News	14
Words from the Chair	14
U SDOT FHWA/NHTSA	15
News from FHWA Washington Division	15
W ST2 Resources	17
O nline Resources	18
T raining Opportunities	20
O ther Training Programs for Local Agencies	25
C onferences	26
S ign of the Times	28

Mayor Unveils Parking Pay Stations; City to Test the Technology for 90 Days

by Jim Seitz, Transportation Specialist,
Association of Washington Cities
On behalf of the City of Spokane

Mayor James West recently launched a 90-day trial of new user-friendly parking pay stations that replace traditional parking meters. The city will be testing the new technology until mid-May.

Forget scrounging for spare change. The solar-powered pay stations accept Visa or MasterCard credit or debit cards — in addition to coins — to pay for parking. After paying for parking, customers receive a receipt that they must display on the front curbside window of their vehicle indicating the expiration time. One station, essentially an electronic kiosk, replaces six to ten meters on a city block.

“The City of Spokane exists to serve its citizens,” says Mayor West. “We want to make it easy for citizens and visitors to enjoy downtown — for business, entertainment, or shopping. That’s what this trial is all about.”

For the 90-day trial, three of the pay stations have been placed on the north side of Main Avenue between Lincoln and Howard. A fourth will be placed in the parking lot just north of City Hall. Parking docents will be available for the first couple of weeks to help citizens use the new pay stations. The docent program is sponsored by the City and the Downtown Spokane Business Improvement District.

Besides increasing convenience for parking customers, the pay stations also are designed:

- To increase parking turnover, which assists merchants.
- To reduce maintenance needs of the city’s parking system and increase effectiveness of city parking employees.
- To improve aesthetics downtown. The pay stations are located one per block and would replace parking meter posts, resulting in additional space on the

sidewalks for pedestrians and elimination of the “picket fence” look of the meters.

While cities across the nation, including Seattle and Portland, have converted to similar technology, Spokane’s trial of the parking pay stations is unique. Officials at Parkeon Inc., the company supplying the pay stations for the trial, say this is the first time that wi-fi technology has been used to allow the pay stations to communicate with operators.

Thanks to the SpokaneHotZone, the pay stations don’t require hard-wire network connections.

The parking pay stations are being loaned for free to the city for the trial. Citizens will be asked to provide their impressions of the pay stations later in the trial period.

Once the trial is over, the city officials will evaluate the success of the program and decide whether to install the parking pay stations more broadly. The city would need 77 units to cover the main core of downtown. Each unit costs between \$7,500 and \$8,500.

More information on the parking pay station trial can be found at www.spokanecity.org



Mayor James West demonstrates the new user-friendly parking pay station.

Avoid the Pitfalls of Over Documenting on FHWA Funded Local Agency Projects

Helpful Tips on How to Appropriately Classify Your NEPA Documents

by Brian Hasselbach,
Environmental Policy Branch
Manager, WSDOT Highways & Local
Programs Division (H&LP)

Background

The National Environmental Policy Act (NEPA) requires all federal agencies, including the Federal Highway Administration (FHWA), to consider both the natural and man-made environments and the values associated with both in approaching the agency's planning and decision-making processes.

NEPA applies to all decisions made that have a federal nexus — that is, use of federal funds, federal approval in the form of permits, or location on federal land.

Environmental analysis begins with determining the appropriate NEPA classification for the project. This is typically one of the initial steps in project development. A project will be classified as one of three defined classes, depending upon the significance of its impacts.

- **Class I** projects include actions that are likely to result in significant impacts to the environment by virtue of their impacts on land use, planned growth, development patterns, traffic volumes, travel patterns, transportation services, natural resources, or due to the likelihood of the

project's ability to create significant public controversy. Class I projects require the preparation of an Environmental Impact Statement (EIS).

- **Class II** projects are actions that generally do not result in significant impacts. Categorical exclusions (CEs) are actions which, based on previous experience with similar actions, do not involve significant environmental impacts. These projects generally require the preparation of an Environmental Classification Summary (ECS) and appropriate supporting discipline reports.
- **Class III** projects are those in which the significance of the project's impacts on the environment are not clearly established. In these situations, an Environmental Assessment (EA) is prepared to determine the extent of environmental impacts and whether the preparation of an EIS is appropriate. An EIS is not required when the findings of an EA support the issuance of a Finding of No Significant Impacts (FONSI) by FHWA.

The NEPA classification needs to occur as early as possible in the project's development, since the scope of the subsequent environmental analysis and documentation process is dependent upon the project's classification.

The Issue

Approximately 90 percent of WSDOT Highways & Local Programs projects (local agency projects funded with FHWA dollars) result in CE determinations. Typically only 10 percent of H&LP's projects result in the need to prepare an EA or EIS. The determination of when to prepare an EA or EIS is often a tricky one, as it is very dependent upon the nature of the project with respect to its location, surrounding environmental considerations, public controversy, etc.

Depending on the complexity of a project and the uncertainty of the significance of issues, it is not unreasonable for a local agency to be unsure of the correct classification for the project or which discipline reports may be necessary. A potential misclassification of the appropriate NEPA documentation and/or supporting discipline reports generally results in unnecessary expenditure of funding and will likely result in delays to the project.

The Solution

NEPA Classification

Agencies must remember that as the lead federal agency, FHWA retains the ultimate authority for determining the appropriate NEPA classification. Securing FHWA's agreement on the classification early in the process will help prevent future delays in re-visiting previous decisions.

Agencies that suspect their project may require the preparation of an EA or EIS are required to contact their Regional Local Programs Engineer immediately. The agency may be asked for additional information to ensure that the correct classification is selected. A meeting will likely occur with FHWA and WSDOT H&LP's Environmental Office. This coordination should occur very early, so as to allow flexibility in how to proceed (i.e., avoid entering into a contract with a consultant to prepare the NEPA documentation, until the full scope of the proposed environmental work is confirmed).

Early coordination will provide an agency with confirmation of the appropriate direction and possibly significant time and resources savings if the classification is "downgraded." For those projects in which an EA or EIS is still appropriate, the early coordination is still extremely valuable in the sense of ensuring FHWA's support of the document and allowing the start of ongoing discussion on project schedules and procedures.

Discipline Reports

Discipline reports are extremely important in providing supporting documentation for the NEPA classification and significance of impacts. Discipline reports may include, but are not limited to, biological assessments; cultural resources surveys; air quality analyses; noise studies; or Section 4(f) analyses.

Most environmental considerations have specific triggers that dictate the need to prepare a discipline report to analyze the impacts of the proposed project on a particular environmental consideration. The WSDOT *Local Agencies Guidelines* (LAG) Manual and *Environmental Procedures Manual* (EPM) provide direction on when it is appropriate to prepare a discipline report and, more importantly, the content that is necessary to support a finding.

For FHWA funded projects, FHWA is the ultimate approving authority on NEPA. WSDOT H&LP assists in the review of the NEPA and supporting documents prior to submittal to FHWA in order to help facilitate a seamless review and approval process when the documents land on FHWA's desk. It is not uncommon for discipline reports to be returned for revision following WSDOT's review, due to missing information, too much or irrelevant information, or because the document is unnecessary (there are no impacts to the specific environmental consideration that need to be analyzed). Revising documents results in added expense to the local agency and delay to the overall project schedule.

Agencies can help ensure as streamlined of an environmental process as possible by using the LAG and EPM to help direct which discipline reports are necessary and, more importantly, ensure the appropriate analysis is included in those reports. If an agency is unsure or has questions regarding the applicability of a discipline report, contact the Regional Local Programs Engineer. Your Regional Local Programs Engineer will coordinate with the H&LP Environmental Office to assist you in confirming direction.

Key Message

Coordinate early, coordinate early, coordinate early! For EA, EIS, and more complex CE projects, it is well worth everyone's time and resources to spend a couple of hours discussing the project early in the project's development to ensure support for a document's classification and discipline reports. Those couple of hours may translate into a tremendous amount of time, financial, and resource savings in the future.

Finally — remember that project proposals often undergo some amount of change during the NEPA process, and new information may be uncovered in the process, so NEPA classifications are **always** subject to change (either elevated or "downgraded" in class).



Jim McManus, Director of Professional Development Programs, UW, Retires

*by Dan Sunde, P.E., Assistant Director,
Project Control and Reporting Office*

Jim McManus resigned as the Director of Professional Development Programs on February 28, after 52 years of professional engineering practice, twelve of which were directing the Transportation Partnership in Engineering Education Development (Transpeed) at the University of Washington.

Over twelve years ago, after retiring from Caltrans as Chief Engineer, Jim took on the task of developing and institutionalizing a new professional development program for Washington's engineering community, a program based on a partnership between WSDOT, local agencies, and the Washington consulting community. From its inception, Jim forged Transpeed into an extremely successful program that services Washington's engineering community, as well as Oregon, Idaho, and California, providing training for over 15,000 engineers. He successfully integrated the program with other professional programs in the Civil and Environmental Engineering Department at the UW, extended specialized training programs to transit and local agencies, and established a close working partnership with WSDOT-H&LP's WST2 Center. Jim was also key to developing and implementing the maintenance training program through Transpeed that was critical in the success of the statewide Regional Road Maintenance Program and 4d coverage for maintenance activities.



Jim McManus retires.

Jim's vision, drive, and creativity have provided a stable program that has continuously exceeded the expectations of both the originators of the program concept and the steering committee that tried their best to keep up with him. Jim's ability to anticipate the need, his innovative thinking, and ability to create effective partnerships have been key to his success.

It's with our gratitude that WSDOT extend our thanks to Jim for all his hard work.

Thank you, Jim. Your leadership and endless energy will be greatly missed. We wish you the very best.



T-Post Adapter for Temporary Signs

Agency:

San Juan County Public Works
Friday Harbor, WA 98250-0729

Contact Person:

Ernie Cable
District 3 Equipment Operator
E-mail Address: erniec@sjcpublicworks.org
Phone: (360) 468-2273

Russ Harvey
Road Operations Manager
E-mail Address: russh@sjcpublicworks.org
Phone: (360) 370-0519

Inventor / Fabricator:

Ernie Cable

Supervisor's Name:

Dick Jenison
District 3 Road Maintenance Supervisor
E-mail Address: dickj@sjcpublicworks.org

What prompted this invention or equipment modification?

For temporary signs such as "Fresh Oil" and "Loose Gravel," we have always bolted the signs to steel T-posts and driven them in with sledge hammers. Very dangerous! With the addition of "Motorcycles Use Extreme Caution" signs, we needed a better way of setting up temporary signs, especially during our chip seal and pavement reclamation operations, during which signs typically remain posted for a few weeks.



Temporary construction sign attached to a T-post.



Driving T-post with standard T-post driver.



T-post adapter installation.



T-post adapter.

How was it developed?

T-posts are still the easiest way to support temporary signs. I have designed a way to easily attach the sign to the T-post AFTER the T-post is set with a standard driver. This works well during chip seal operations when temporary construction signs typically remain posted for a few weeks. Using the new system, the sign may be adjusted for height and angle, and the post can be pulled with a T-post puller.

Labor, Equipment, Materials Used:

Labor:

40 minutes each, based on using a custom jig to fabricate 100 pieces.

Equipment:

MIG welder, drill press, band saw.

Materials for each:

- (1) 15.5" 2x2x.120 box tubing
- (2) 9" 3/16x1.5 flat bar
- (1) 2" 3/16x1 flat bar
- (2) 1/2x1.75x13 NC hex set screws
- (2) 1/2x13 NC nuts
- safety orange paint

Cost Estimate:

\$27.00 each, based on fabricating 100; \$7 materials, \$20 labor.

Benefits to Your Operations:

Benefits include faster and safer installation of temporary signs — we use a T-post driver for setting the post and a T-post puller for removal. Additionally, there is some adjustability of height and angle of the sign attached to the post.

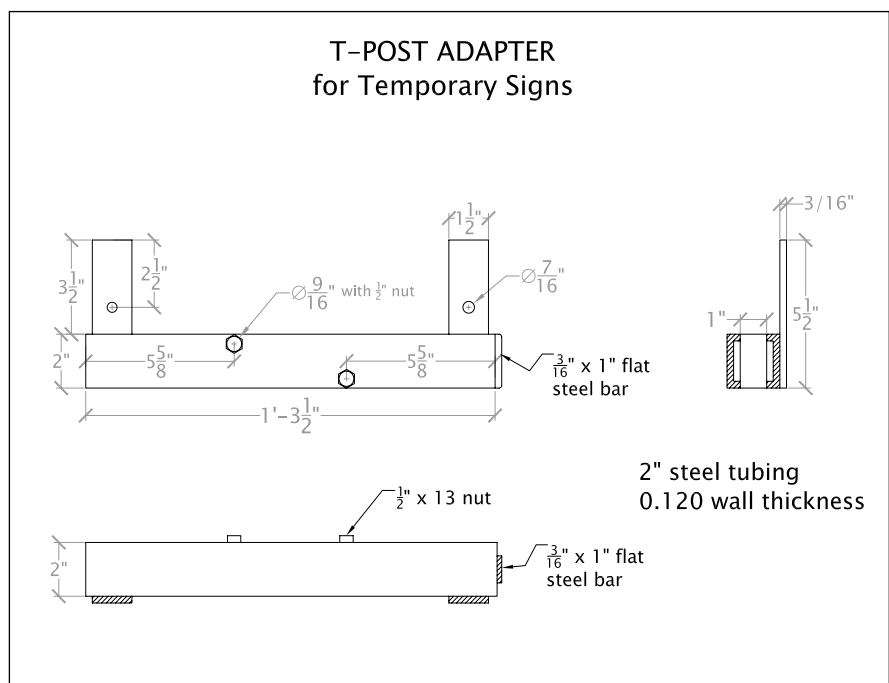
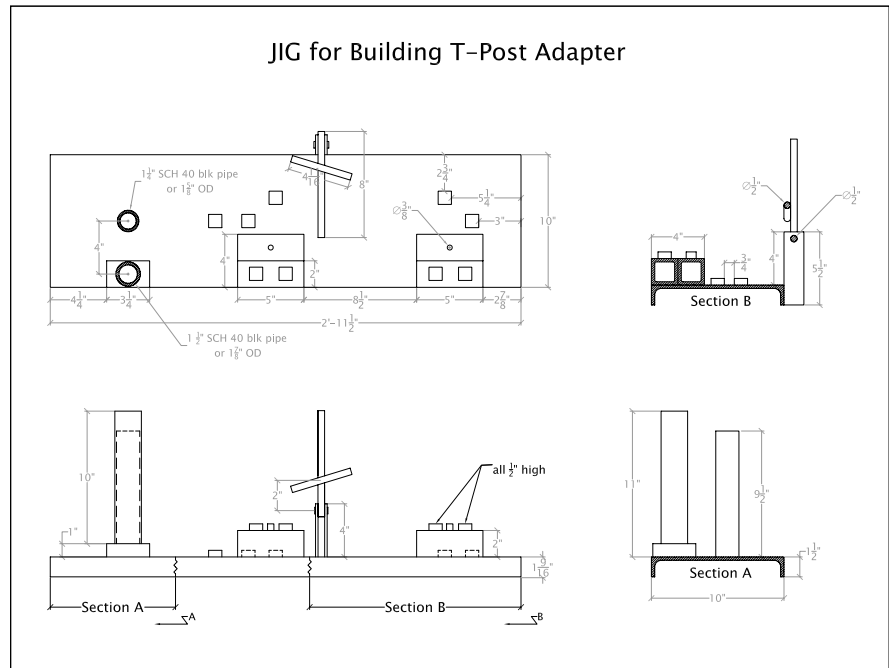

New Infiltration Pond Design Methods Developed by WSDOT



The Problem

This research was initiated to deal with the problem of sizing infiltration ponds associated with highway construction projects. Existing methods for estimating infiltration rates often resulted in ponds that were oversized or undersized as measured by the actual operation of the pond in collecting and infiltrating the runoff from the highway facility.

The Research

Full-scale flood tests in addition to analysis of the performance of a number of existing ponds were performed to develop a methodology for more accurate assessment of infiltration rates. The full-scale "flood tests" conducted at four infiltration facilities in Western Washington suggested that lateral flow along the sides of the ponds may be significant. It appeared that more efficient designs may require a larger ratio of side area to bottom area and that maintenance activities should be considered for the sides as well as the bottom of the pond.

Saturated hydraulic conductivity values were compared to full-scale infiltration rates for 15 sites in Western Washington. The estimated values for saturated hydraulic conductivity were up to two orders-of-magnitude different than the full-scale infiltration rates for some sites. These results show that infiltration rates cannot be reliably estimated on the basis of soil properties alone; information related to the hydraulic gradient is also important.

Groundwater flow computer models were compared to identify the flow systems for which saturated models provide reasonable approximations. The difference between saturated and unsaturated flow models was lowest in highly permeable soils and increased as the soil permeability decreased. The simulations suggest that steady-state infiltration rates calculated with a saturated model will be 20 to 30 percent smaller than rates calculated with an unsaturated model for the range of hydraulic conductivities typically found beneath Western Washington infiltration ponds. A comparison of steady state and transient simulations showed that the steady state assumption might significantly underestimate infiltration rates.

The Results

A report and a design manual were developed and are available that describe the step-by-step procedures for collecting and analyzing data and information needed to size infiltration ponds. The procedures were developed recognizing that the performance of infiltration facilities depends upon a combination of near surface soil characteristics, subsurface geology, groundwater conditions, and pond geometry. The manual focuses on infiltration ponds located in unconsolidated geologic materials.

The report and design manual are available on the web at: <http://www.wsdot.wa.gov/biz/mats/Geotech/>

The results of this research and the design procedures developed have been fully implemented in the WSDOT *Highway Runoff Manual*. This manual is available on the web at: <http://www.wsdot.wa.gov/fasc/Engineering/Publications/Manuals/HighwayRunoff2004.pdf>

How Local Agencies Can Use This Information

Local agency project designers may also benefit from this information and use the design manual as guidance in developing new infiltration ponds or determining whether an existing infiltration pond is adequate. The *Local Agency Guidelines* (LAG) Section 24.74 refers local agencies to use the *Highway Runoff Manual* or local ordinances (if more stringent) to design stormwater treatment facilities.

Technical Contact Information

For more information on this research or how it is being used within WSDOT, please contact Tony Allen at (360) 709-5450 or e-mail: AllenT@wsdot.wa.gov

For a hard copy of the research report or the design manual, contact Sarah Smith in the WSDOT Research Office at (360) 705-7971 or e-mail: SmithSa@wsdot.wa.gov

Study Authors

The researcher was Joel Massmann, the technical advisor at WSDOT was Tony Allen, and project manager in the WSDOT Research Office was Keith Anderson.

The *Gray Notebook* is a quarterly publication published by the Washington State Department of Transportation to track a variety of performance and accountability measures for review by the Transportation Commission

and others. The following is a sampling from this document. For an online version of this or a previous edition of the *Gray Notebook*, visit <http://www.wsdot.wa.gov/accountability/>



Measures, Markers and Mileposts

The Gray Notebook for the quarter ending
December 31, 2004

WSDOT's quarterly report to the
Washington State Transportation Commission
on transportation programs and department management

Douglas B. MacDonald
Secretary of Transportation



Highway Safety Improvement Projects: Annual Update

Safety Enhancements - Are They Reducing Collisions?

Twenty-One Safety Projects Revisited

Each year, WSDOT completes a variety of safety improvement projects throughout the state highway system, ranging from adding turn lanes and signals to installing median barrier and rumble strips.

To determine their effect on reducing the number and severity of traffic collisions, a second before-and-after study has been conducted to confirm the results of the 21 projects analyzed one year ago in the December 2003, *Gray Notebook* (GNB) edition. Projects were chosen that permitted at least 18 months of collision data to be analyzed in the Before period, and at least 12 months in the After period. The data was then normalized (12 month average) to make a valid comparison.

Combined Average for 21 Safety Projects

Collisions per Year

	All Types	Property Damage Only	Injury/ Fatal
Before Totals	15.2	8.6	6.6
After Totals	8.7	5.2	3.5
Percent Reduction	43%	40%	47%

Source: WSDOT Transportation Data Office

The preliminary results indicated that for the original 21 projects, the average number of collisions per year for all projects combined was reduced by 37 percent. With the additional data now available, the reduction is even greater at 43 percent. Similarly, the average number of fatal and injury collisions per year has been reduced even further, from 37 percent to 47 percent.

The current study helps confirm the results of the preliminary efforts, which was based on statistically limited collision data. In order to solidify the information further, WSDOT will review the data in another year, so that a full three years can be used for the "After" portion of the study.



I-82 in the vicinity of milepost 116.

Follow-up Analysis - I-82/Union Gap to Oregon State Line

In last year's Highway Safety Improvement Projects: Before and After Results, 22 safety projects were originally identified for analysis. One project, I-82/Union Gap to Oregon State Line (see GNB December 2003 edition), was identified for further analysis due to concerns that the long length of the project (approximately 100 miles), the weather variations, and increased traffic volumes in different locations throughout the project were skewing the data.

WSDOT recently completed the analysis which shows that the addition of durable lane striping did not have a significant effect on reducing collisions. Collision rates declined slightly from 9.9 to 9.1.

Although durable lane striping resulted in limited collision reduction, increased striping visibility is still believed to have significant benefits, and provides an element of driver comfort. Continued tracking to monitor and control for variances in weather patterns is necessary to ensure statistical validity of the impacts of the safety improvement over time.

Highway Safety - Pedestrians: Annual Update

Pedestrian Safety in Washington

In Washington, pedestrian fatalities are 14 percent of all transportation related fatalities. This is much too high.

Most pedestrian fatalities in Washington occurred on arterial roads (principal or minor arterials). From 1994 to 2004 over 60 percent of pedestrian fatalities occurred on arterials.

The combination of driver action and pedestrian risk taking behavior continue to influence pedestrian fatality rates. In almost 50 percent of pedestrian fatalities, crosswalks were not available. Another 8 percent of pedestrian fatalities occurred in the roadway shoulder where sidewalks were not available.

Seattle Metro Area

The Seattle-Tacoma-Bremerton metropolitan area ranked tenth highest in the nation for the percent of traffic deaths that involved pedestrians.

Additionally, it is one of the metro areas in the country where pedestrian safety seems to be worsening since 1994.

Large National Metro Areas with Highest Pedestrian Deaths

Metro Area	Number of Pedestrian Fatalities (2002)	Number of Pedestrian Fatalities (2003)	Percent of Traffic Deaths that were Pedestrians
New York-Northern New Jersey-Long Island, NY-NJ-CT-PA	395	377	28%
Miami-Fort Lauderdale, FL	119	119	22%
San Diego, CA	74	62	22%
San Francisco-Oakland-San Jose, CA	118	110	21%
Los Angeles-Riverside-Orange County, CA	118	110	21%
Tampa-St Petersburg-Clearwater, FL	97	88	21%
Detroit-Ann Arbor-Flint, MI	119	105	20%
Buffalo-Niagara Falls, NY	17	18	19%
Chicago-Gary-Kenosha, IL-IN-WI	155	157	19%
Seattle-Tacoma-Bremerton, WA	45	55	18%

Source: Mean Streets 2004, Surface Transportation Planning Project

Location of Pedestrian Fatalities

Number of Fatalities	
In Crosswalk	121
Not In Crosswalk	167
Crosswalk Not Available	408
Shoulder	67
Other - Off Roadway	34
Unknown	35

Source: Mean Streets 2004, Surface Transportation Planning Project

Highway Safety: Annual Update

Seatbelt Use in 2004

Washington Ranks Third

The September 30, 2003 *Gray Notebook* reported that Washington's seatbelt use rate was the highest in the United States at 94.8 percent. Since that time, the U.S. Department of Transportation reports that two other states, Arizona and Hawaii, have achieved slightly higher use rates. Arizona's use rates can be attributed in great part to efforts on a Click-It-Or-Ticket campaign, and intensive law enforcement efforts. Hawaii's higher use rates are primarily the result of a media campaign, and an intensive law enforcement effort. The results are from probability-based observational surveys conducted by 51 states and territories in accordance with criteria established by the National Highway Traffic Safety Administration.

A recent study conducted at the Harborview Injury Prevention Center found that, when used correctly, lap and shoulder belts were 70 percent effective in preventing deaths and 50 percent effective at preventing injuries.

Enforcement and the seatbelt law may also have a positive effect on reducing the number of drinking driver-involved collisions. For the years 2000-2002, the average number of fatalities for drinking driver-involved collisions was 251 compared to 221 in 2003.

Percent of Seatbelt Use

Top Six Ranking States in 2003 and 2004

Rank	State	2003 Percent	2004 Percent
1	Arizona	86.2	95.3
2	Hawaii	91.8	95.1
3	Washington	94.8	94.2
4	Oregon	90.4	92.6
5	Michigan	84.8	90.5
6	California	91.0	90.4

Special Features

Is Photo Enforcement a Safety Tool?

The use of cameras to capture red light violations is beginning to catch on around the United States as an effective means of deterring illegal and dangerous driver behavior at signaled intersections. Performance results are starting to accumulate, supporting years of data that has been available from Europe and Australia. Camera enforcement has been used in New York City since 1993. As the safety payoffs from camera enforcement are documented, use of the cameras should grow.

In 2000 the Washington State Legislature directed the Washington Traffic Safety Commission to select, monitor and evaluate automated enforcement sites within Washington State and set out guidelines. In the 2001 - 2002 session, the Legislature approved the use of photo enforcement at signalized intersections and work zones by WSDOT and four municipalities (sixteen other states and the District of Columbia have also passed such legislation). So far only the City of Lakewood has actually installed the cameras, in a program participated in by public works and police staff and supported by the municipal court. Lakewood's system was installed July 2001.

City of Lakewood Results: Fewer Violations / Fewer Collisions

After red light cameras were installed and operating for three months, red light running violations decreased 36 percent. Red light violations dropped by 61 percent in less than a year. No collisions occurred in the first six months after the installation.

Protecting Lakewood School Zones

Lakewood has also used photo enforcement at school zones to help enforce 20 mph speed limits while school children arrive and depart from school. At the sites where the systems were installed and operating for three months, speeds dropped between 3 and 10 mph.

Red Light Violations, City of Lakewood

	July 2001	May 2002
Violations	1585	614

Number of Angle Collisions - Before and After Results, City of Lakewood

	6 months before:	Immediate 6 months after:	2.5 years after
Angle Collisions	2	0	3



According to the National Highway Traffic Safety Administration (NHTSA), approximately 1,000 individual fatalities occur each year in red-light running incidents. Advocates of the cameras (including NHTSA) have championed them as effective tools in reducing accidents and deaths.

Virginia Gets Results

A recently completed study in Fairfax County, VA looked at 13 intersections that were equipped with photo enforcement to deter red light running behavior. Results indicate that the number of violators dropped between 63 and 72 percent after the cameras had been in service for two years.

More information on photo enforcement can be found at: www.ihs.org/safety_facts/qanda/rlc.htm



*By Matt Fengler, NWPMA President
City of Tacoma
Pavement Management Coordinator*

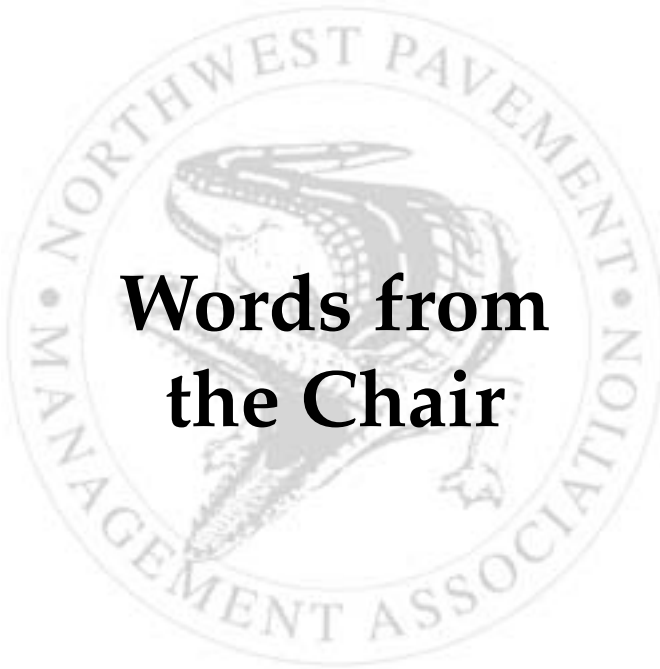

Words from the Chair

I would like to thank the sponsors, organizers, presenters, and the participants of the 2004 NWPMA Fall Conference which was hosted by the City of Tacoma and Pierce County. The conference was a great success. A highlight was the wonderful afternoon spent on Puget Sound touring the Port of Tacoma's new Pierce County Terminal and one of the largest transportation projects in the nation, the new Tacoma Narrows Bridge Project. Our group was fortunate to have engineers from both projects on board sharing their insights into these monumental projects.

Membership in the NWPMA and participation in these conferences allows individuals and agency representatives the opportunity to ask questions, solve problems, share information, and make new acquaintances. Each year, the conference brings fresh ideas and new products to pavement management. Pavement management is a vital portion of transportation planning and, as we all know, transportation is a regional issue that transcends political boundaries. I encourage all agencies in Washington, Oregon, and Idaho to become members of the NWPMA. Many agencies will use new processes and materials in their maintenance practices this year in an effort to maximize the life-cycle of their pavements and to increase their return on investment. I would invite these agencies to participate and share their maintenance challenges and successes at future conferences.

We've all heard it before, "knowledge is power." This statement exemplifies pavement management itself. The information we convey to others empowers them to make good decisions that affect maintenance, development, budget, and strategic planning for many years. Join me in 2005 to advance the field of pavement management. Attend our spring or fall conference and benefit from the expertise of many other pavement management professionals from throughout the region.

I am honored to have been elected the President of the NWPMA and look forward to serving you in 2005. Each and every one of us faces a shrinking budget and increased expectations from our customers. It's a quandary, but is not insurmountable. Membership in the NWPMA and participation at our conferences offers the best opportunity to stay abreast of new products, new ideas, and emerging trends.

Thank you again to those who participated in the 2004 Fall Conference, and I look forward to the year ahead.



News from FHWA Washington Division

By Liana Liu, P.E., PTOE
Traffic/Safety/Research/T2 Engineer
FHWA Washington Division

Pedestrian Safety Campaign

The Pedestrian Safety Campaign is a FREE ready-made toolkit of outreach materials that states and communities can customize and use locally. The threefold purpose of the campaign is to (1) sensitize drivers to the fact that pedestrians are legitimate road users and should always be expected on or near the roadway; (2) educate pedestrians about minimizing risks to their safety; and (3) develop program materials to explain or enhance the operation of pedestrian facilities, such as crosswalks and pedestrian signals.

The toolkit includes materials designed for use in television, radio, cinema, and print advertising. Some of the materials included are in Spanish. States and local communities would be responsible for implementing the campaign through local television and radio stations and print media.

For more information, contact Aida Berkovitz at (415) 744-2614 or Frank Julian at (404) 562-3689. To view the campaign materials, go to <http://safety.fhwa.dot.gov/fourthlevel/ped.htm> and click on "Pedestrian Campaign."

The Pedestrian Safety Guide and Countermeasure Selection System (Pedsafe)

Pedsafe is a newly completed pedestrian safety product and is known as the Pedestrian Safety Guide and Countermeasure Selection System. It is intended to provide practitioners with the latest information available for improving the safety and mobility of those who walk. The online tools provide the user with a list of possible engineering, education, or enforcement treatments to improve pedestrian safety and/or mobility based on user input about a specific location.

The Pedsafe Guide provides information on 47 engineering countermeasures or treatments, along with education and enforcement programs, that may be implemented to improve pedestrian safety and mobility. Included in this version are 71 case studies that illustrate these concepts applied in practice in a number of communities throughout the United States.

The Pedsafe Program can be accessed at <http://www.walkinginfo.org/pedsafe/>. To order copies of the guide or the program itself, go to http://safety.fhwa.dot.gov/ped_bike/ped_bike_order.htm or contact Tamara Redmon at (202) 366-4077.

Web-based Tool to Assist in Setting Realistic, Safe, and Consistent Speed Limits

A beta version of a web-based speed zone advisor known as USLIMITS is now available at <http://www.uslimits.com>. The expert system recommends a speed limit for a section of road based on road function, roadside development, operating speeds, road characteristics, and other factors required to determine appropriate speed limits in speed zones. The system also warns users of issues that might require further investigation and engineering judgment. USLIMITS provides a screen report and a more detailed report. USLIMITS will be of particular use to small communities and agencies that lack experienced traffic engineers. For experienced traffic engineers, it can provide a second opinion and increase confidence in speed zoning decisions. A user account is required to save projects and view the detailed speed zoning report, but

anyone can trial USLIMITS by entering "guest" for the username and password. For more information, contact Davey Warren at (202) 366-4668.



Retroreflectivity Marketing Tools

Retroreflectivity, or nighttime visibility of signs and pavement markings: (1) provides critical information to drivers at night, (2) helps drivers navigate the road during nighttime hours, (3) enhances traffic flow and driver mobility, and (4) promotes safe driving.

Now three Retroreflectivity Marketing tools are available, which are:

- How Retroreflectivity Makes Our Roads Safer video
- Night Lights Marketing Tool Kit (brochure, flyer, and Q&A sheet)
- Retroreflectivity Sheeting Identification Guide

For additional information, please visit the FHWA retroreflectivity web site at <http://safety.fhwa.dot.gov/programs/retroref.htm> or contact Peter Hatzi at peter.hatzi@fhwa.dot.gov, Kenneth Opiela at kenneth.opiela@fhwa.dot.gov, or Greg Schertz at greg.schertz@fhwa.dot.gov.



Retired Professionals: Ready to Work for You

Need help with a special project? Need the skills and experience of a public works professional? The Washington State Department of Transportation Highways & Local Programs' WST2 Center's database of Retired Professionals may be just what you need. It is a skills bank of professionals with expertise in maintenance, operations, engineering, inspection, construction, and surveying, just to name a few. You can browse through the listings from the T2 home page:

<http://www.wsdot.wa.gov/TA/T2Center/T2hp.htm>
Click on Retired Professional Program

We would like to increase the awareness of this program. We encourage you to tell your staff and soon-to-be-retired employees about this program. We would like to see this skills bank grow and become a strong, extensive, and useful resource for agencies when there is a need for outside professional help.

Are you retiring soon? Want to continue with part-time, full-time, or occasional employment? You can now enter your résumé directly online by going to:

http://fmapps.wsdot.wa.gov/retired_professional_reviewer

Enter all of your information and give yourself a Retiree Identifier that will allow you, and only you, to return at another time to make changes to your record. Then, click the register button. A window will pop up asking for a User ID and Password. You should enter:

User ID: retired

Password: kindof

This will be the only time you enter the User ID and Password.

Your résumé will be sent to Laurel Gray for review and posting to the web. If you prefer, you can access the first web site above for a hard copy of the form to send to the WST2 Center.

If you have questions, contact Laurel Gray at (360) 705-7355 or GrayL@wsdot.wa.gov.

Free Publications from Your WST2 Center

For State of Washington residents only due to high mailing costs.

Name		Agency	
Mailing Address	City	State	Zip+4
Phone	Fax	E-mail	

Order direct from the WSDOT home page:

<http://www.wsdot.wa.gov/TA/T2Center/T2PUBS.htm>

Or you may fax the form to (360) 705-6858; or mail the form to WST2/WSDOT, H&LP, PO Box 47390, Olympia, WA 98504-7390; or e-mail your request to WST2Center@wsdot.wa.gov; or phone (360) 705-7386.

- Check the items you would like to order.

Hard Copy Publications

- Accessible Sidewalks and Street Crossings, FHWA, 2003
- Asset Management Primer, FHWA, 1999
- Building Projects that Build Communities, WSDOT, 2003
- Concrete PASER Manual, University of Wisconsin, 1998
- Data Integration Primer, FHWA, 2001
- Designing Sidewalks and Trails for Access, Part 2, FHWA, 2001
- Dust Control on Low Volume Roads, FHWA, 2001
- Entering the Quiet Zone, FHWA, 2002
- Field Guide for Unpaved Rural Roads, Wyoming T2 Center, 1997
- Fish Passage Through Culverts, FHWA, USDA, 1998
- General Field Reference Guide (Pocket Size), 2002
- A Guide for Erecting Mailboxes on Highways, AASHTO, 1984
- HMA Pavement Smoothness, FHWA, 2002
- Improving Conditions for Bicycling and Walking, FHWA, 1998
- Improving Highway Safety at Bridges on Local Roads and Streets, FHWA, 1998

- Increasing Physical Activity Through Community Design, 2002
- Maintenance of Aggregate and Earth Roads, WST2 Center (1994 reprint)
- Pavement Preservation Checklist, FHWA, six pocket guides
 1. Crack Seal Application
 2. Chip Seal Application
 3. Thin Hot-Mix Asphalt Overlay
 4. Fog Seal Application
 5. Microsurfacing Application
 6. Joint Sealing Portland Cement Concrete Pavements
- Pedestrian Safety for the Older Adult (65+), NHTSA
- Recommendations to Reduce Pedestrian Collisions, WSDOT, December 1999
- Reflective Sheeting Identification Guide, FHWA, 2001
- Roadway Safety Tools for Local Agencies, NCHRP, Synthesis 321, TRB, 2003
- Scenic Byways Map of Washington State, 2003
- Traffic Control Handbook for Mobile Operations at Night, FHWA, 2003
- Trail Construction & Maintenance Notebook, USDA Forest Service, 2000
- Utility Cuts in Paved Roads, Field Guide, FHWA, 1997
- W-Beam Guardrail Repair and Maintenance, FHWA, 1996
- A Walkable Community is More Than Just Sidewalks Brochure, FHWA, 2000

- Washington Bicycle Map, WSDOT, 2001
- Wildlife Habitat Connectivity Across European Highways, FHWA, 2002

Workbooks and Handouts from WST2 Center Workshops

- Application of Geographic Information Systems for Transportation, FHWA, 1999
- Construction Documentation: Construction Training Manual for Local Agencies, WSDOT, 2005
- Context Sensitive Solutions in Washington, WSDOT and CH₂M Hill, 2004

Videotapes

- Driving Modern Roundabouts, City of Lacey, City of Olympia, and WSDOT, 2002
- Modern Roundabouts: Tomorrow's Solution for Today's Traffic, City of Bellingham, 2005
- Pacific Northwest Transportation Technology Expo and Mousetraps

CD ROM

- H&LP CD Library (formerly WST2 CD Library), 6th Edition, Summer 2004 contains the following publications and many other technical documents:
 - Asphalt Pavement Repair Manuals of Practice, SHRP, 1993
 - Asphalt Seal Coats, WSDOT/WST2 Revised 2003

- Building Projects that Build Communities, Community Partnership Forum, 2003
- Concrete Pavement Repair Manuals of Practice, SHRP, 1993
- Dust Palliative Selection and Application Guide, USFS, 1992
- Erosion Control Handbook for Local Roads, FHWA & Minnesota Local Road Research Board
- Gravel Roads Maintenance and Design Manual, South Dakota LTAP, November 2000
- A Guide for Local Agency Pavement Managers, NWT2 Center, 1994
- Local Agency Pavement Management Application Guide, WST2 Center, 1997
- Local Agency Safety Management System, WSDOT, 1998, Reprinted 2000
- Maintenance of Signs & Sign Supports for Local Roads and Streets, FHWA, 2001
- Manual of Practice for an Effective Anti-icing Program: A Guide for Highway Winter Maintenance Personnel, FHWA, 1996
- Pavement Surface Condition Field Rating Manual for Asphalt Pavement, NWPMA, WSDOT, 1999
- Roundabouts: An Information Guide, FHWA, 2000
- Streetwise, A Simplified Local Agency Pavement Management System, WSDOT, 2000

New Videos in WST2 Video Lending Library!

- #471 **Defensive Driving for Government Employees**, Coastal Safety & Environmental, 2004. Motor vehicle accidents are the leading cause of death on the job for government employees. This video shows techniques to help prevent accidents and to lessen the severity of unavoidable accidents. It addresses defensive driving, driver responsibilities, safe driving techniques, driving in poor weather, speeding, tailgating, distractions, and road rage.

- #472 **Hazard Recognition and Control, Coastal Safety & Environmental**, 2004. This video shows workers the key to safety on the job: recognizing and controlling hazards using hazard scenarios to point out the direct, indirect, and root causes of accidents. It also explains the responsibilities of supervisors, team leaders, and employees.

Other CDs

- Driving Modern Roundabouts, City of Lacey, City of Olympia and WSDOT, 2002
- Emergency Relief Training for Washington State Local Agencies, WSDOT, 2004
- Pedestrian Facilities Guidebook, WSDOT, 1997
- Safer Journey, FHWA, 2003 (Pedestrian)
- WSDOT Engineering Publications CD Library, March 2004
- Work Zone Safety for Roadway Maintenance Operations, Interactive Training Course Advanced Technology Concepts with Rutgers University

DVD

- Danger Signs, 2004
- Driving Modern Roundabouts, City of Lacey, City of Olympia and WSDOT, 2002
- Pedestrian Safety, City of Olympia and Washington Traffic Safety Commission, 2004

Self-Study Guides

These non-credit WSDOT self-study guides may be obtained from the WST2 Center. An invoice will be sent with the books.

- Basic Surveying, \$20
- Advanced Surveying (metric), \$20
- Contract Plans Reading, \$25
- Technical Mathematics I, \$20
- Technical Mathematics II, \$20
- Basic Metric System, \$20

Bridge

- WSDOT Highways & Local Programs <http://www.wsdot.wa.gov/TA/Operations/BRIDGE/BRIDGEHP.HTM>

Environmental

- *Environmental Procedures Manual* (M31-11) <http://www.wsdot.wa.gov/fasc/EngineeringPublications/Manuals/EPM/EPM.htm>
- Regional Road Maintenance Endangered Species Act Program Guidelines <http://www.metrokc.gov/roadcon/bmp/pdfguide.htm>
- National Marine Fisheries Service Species Listings & Info <http://www.nwr.noaa.gov/>
- U.S. Fish and Wildlife Service Species Listings & Info <http://endangered.fws.gov/>
- Washington State DNR's Natural Heritage Program Home Page <http://www.wa.gov/dnr/htdocs/fr/nhp/refdesk/fsrefix.htm>
- FHWA's Environmental Home Page <http://www.fhwa.dot.gov/environment/index.htm>

Highways & Local Programs List Servs

For the following list servs:

- WST2 Newsletter
- WST2 Training
- Traffic Technology and Safety

Use the following address to sign up:

<http://www.wsdot.wa.gov/TA/T2Center/T2hp.htm>

WSDOT Materials Lab

- <http://www.wsdot.wa.gov/biz/mats>

Infrastructure Management & GIS/GPS

The site below has been established to promote interagency data exchange and resources sharing between local governmental agencies.

<http://www.wsdot.wa.gov/TA/T2Center/Mgt.Systems/InfrastructureTechnology/Infathp.html>

Legal Search

- Search RCWs and WACs
<http://search.leg.wa.gov/pub/textsearch/default.asp>

Local Agency Guidelines (LAG) Manual

- <http://www.wsdot.wa.gov/TA/Operations/LAG/LAGHP.htm>

Pavement Management

- Pavement Publications & NWPMA Links
<http://www.wsdot.wa.gov/TA/T2Center/Mgt.Systems/PavementTechnology>
- NWPMA – North West Pavement Management Association
<http://www.wsdot.wa.gov/TA/T2Center/Mgt.Systems/PavementTechnology/nwpma.html>
- Asphalt Institute
<http://www.asphaltinstitute.org/>
- National Asphalt Pavement Association
<http://www.hotmix.org/>
- Pavement (A Website for Managing Pavements)
<http://www.mincad.com.au/pavenet>
- SuperPave Information
<http://www.utexas.edu/research/superpave>

Project Development

- Federal Aid Progress Billing Form
<http://www.wsdot.wa.gov/TA/ProgMgt/Projectinfo/BILLFORM.XLS>
- State Funded Progress Billing Form
<http://www.wsdot.wa.gov/TA/ProgMgt/Projectinfo/BILLFORMSTATE.xls>
- STIP (State Transportation Improvement Program)
<http://www.wsdot.wa.gov/TA/ProgMgt/STIP/STIPHP.htm>

- TIP (Local Agency 6-Year Transportation Improvement Program)
<http://www.wsdot.wa.gov/TA/ProgMgt/STIP/TIP.html>

Research

- WSDOT Research Office
<http://www.wsdot.wa.gov/research>
- Looking for a Transportation Research Publication?
<http://gulliver.trb.org>
- Municipal Research and Services Center of Washington
<http://www.mrsc.org>

Traffic & Safety

- Safety Management Publications & Information
<http://www.wsdot.wa.gov/TA/T2Center/Mgt.Systems/SafetyTechnology/>
- WSDOT Traffic Data Office
<http://www.wsdot.wa.gov/mapsdata/tdo/>
- Washington State Patrol
<http://www.wsp.wa.gov>
- Washington Traffic Safety Commission
<http://www.wtsc.wa.gov>
- National Highway Traffic Safety Administration
<http://www.nhtsa.dot.gov>
- American Traffic Safety Services Association
<http://www.atssa.com>
- Municipal Research and Services Center of Washington
<http://www.mrsc.org>
- Transportation Research Board
<http://gulliver.trb.org>

Training

- WST2 Classes
<http://www.wsdot.wa.gov/TA/T2Center/Training/>
- WST2 Class Registration
http://fmapps.wsdot.wa.gov/tbase_registration/
- County Road Administration Board
<http://www.crab.wa.gov/>
- American Public Works Association
<http://www.apwa.net/education>
- Transportation Partnership in Engineering Education Development (TRANSPED)
<http://www.engr.washington.edu/epp>

WSDOT Local Programs Engineers

- Eastern Region (Spokane)
Keith Martin, (509) 324-6080,
martink@wsdot.wa.gov
- Northwest Region (Seattle)
Ed Conyers, (206) 440-4734,
conyere@wsdot.wa.gov
- Olympic Region (Olympia)
Neal Campbell, (360) 357-2666,
campben@wsdot.wa.gov
- North Central Region (Wenatchee)
Paul Mahre, (509) 667-3090 or 667-2900,
mahrep@wsdot.wa.gov
- South Central Region (Yakima)
Roger Arms, (509) 577-1780,
armsr@wsdot.wa.gov
- Southwest Region (Vancouver)
Bill Pierce, (360) 905-2215,
pierceb@wsdot.wa.gov

Other Online Resources

- Bicycle maps and other information
<http://www.wsdot.wa.gov/bike/>
- Pedestrian information
<http://www.wsdot.wa.gov/walk/>
- Rural Partnerships and scenic byways information
<http://www.wsdot.wa.gov/TA/progmgt/byways/>
- Better Mousetraps
<http://www.wsdot.wa.gov/ta/T2Center/Mousetraps/>
- Retired Professional Program
<http://www.wsdot.wa.gov/TA/T2Center/Retired.htm>
- Student Referral Program
<http://www.wsdot.wa.gov/TA/T2Center/StudentReferral/>
- LTAP (Local Technical Assistance Program) Clearing House
<http://www.ltapt2.org>
- Institute of Transportation Engineers
<http://www.ite.org>
- Washington State Counties
<http://mrsc.org/byndmrsc/counties.aspx>
- Washington State Cities and Towns
<http://mrsc.org/byndmrsc/cities.aspx>
- Governor's Office of Indian Affairs
<http://www.goia.wa.gov>
- Southwest Interagency Coop - Grounds Equipment Maintenance (GEM)
<http://www.gematwork.org>

Washington State T2 Center

Contact: Laurel Gray (360) 705-7355
Wendy Schmidt (360) 705-7386
<http://www.wsdot.wa.gov/TA/T2Center/Training>

To register for a class in this section, use the contacts listed above.

The class fees shown apply to both public and private sector students. Online registrations are now being accepted for the following 2005 and 2006 classes. Updated information on these courses, and the link to online registration can be obtained from the web page listed above.

Bridge Condition Inspection Update (BCIU)

2006: February 1-2, Eastern Washington; February 15-16, Lacey. **Free.** Instructor: Grant Griffin, WSDOT Bridge Engineer. This course will provide information on the latest inspection manual, Laptop98 bridge inspection software, bridge file records, and other important bridge inspection issues. Sufficiency ratings and proper coding of bridge elements will also be discussed.

Bridge Condition Inspection Fundamentals (BCIF)

2006: February 7-9, Lacey. **Free** to Washington State local agencies and consultants. All others \$150. Instructor: Grant Griffin, WSDOT Bridge Engineer. This course is designed to provide basic knowledge of bridge condition inspection, construction materials, material properties, bridge components and nomenclatures, loadings, stresses and strains, and deterioration of bridge materials and members. For engineering or design technicians and other personnel who have little or no background in bridges. This course is preparatory for BCIT.

Bridge Condition Inspection Training (BCIT)

2006: March 13-24, Lacey. **Free** to Washington State local agencies and consultants. All others \$700. Instructor: Grant Griffin, WSDOT Bridge Engineer. This training is for new bridge inspectors or those who desire a refresher. It is based on the FHWA "Bridge Inspector's Reference Manual" and will provide extensive training on the condition inspection of in-service bridges. Two comprehensive examinations will be administered: a field exam covering inspection and inventory coding, and a multiple choice classroom exam. Satisfactory completion of this course will

fulfill the training requirements of the National Bridge Inspection Standards (NBIS) for a "comprehensive training course" based on the reference manual for new bridge inspectors.

Construction Documentation

2005: October 25, Spokane; December 13, Shoreline; December 14, Kent.

2006: January 10, Port Orchard; January 11, Tacoma; January 30, Vancouver; February 1, Olympia; February 14, Wenatchee; February 16, Kennewick; March 14, North Seattle; March 15, East Seattle.

Free. Instructor: Ken Hash, WSDOT SW Region Engineer. Regional Local Program Engineers will be in attendance at each class to answer questions. This course covers three project phases: pre-contract, contract, and post-contract documentation of public works projects with FHWA funding. Local agency and contractor's documentation is discussed, with a strong emphasis on the documentation requirements of the field inspector. On completion of this course, participants will have a working knowledge of: (1) required documentation that will be submitted by the contractor, (2) required documentation for acceptance of contract materials, (3) daily inspector's documentation of the contract work, and (4) source documentation for the monthly progress payment to the contractor.

Contract Specification Writing

2005: May 19, Tacoma; September 20, Everett; October 5, Kent; November 16, Port Orchard.

2006: April, Spokane; May, Vancouver; September, Seattle; October, Lacey; November, Mt. Vernon.

\$75. Instructor: Steve Boesel. This class will provide guidance and methods for writing consistently clear, concise, complete, and well formatted contract special provisions. It will provide a thought process that can be used when writing or reviewing contract specifications to ensure the greatest possibility for a successful bid and a successful construction project.

Designing Accessible Pedestrian Facilities

June 7-8, Tacoma. **\$100.** Instructor: Ida van Schalkwyk, University of Arizona. The provision of accessible pedestrian facilities is mandated by the Federal Americans with Disabilities Act. This course provides a solid background on many aspects of the Americans with Disabilities Act and its interpretation by the Access Board and the courts. The course covers the characteristics of pedestrians, people with disabilities, legal requirements, policies and funding opportunities and focuses on accessible pedestrian design.

Low Cost Safety Improvements

August 16, Shoreline; August 17, Shoreline; August 18, Moses Lake. **Free.** Instructor: John McFadden, P.E., FHWA Baltimore Resource Center, Baltimore, Maryland. The purpose of this course is to provide participants with methods for implementing effective, low-cost safety improvements targeted at high crash areas. It emphasizes the basic and enhanced application of traffic control devices, low cost safety improvements, and their specific safety benefit (crash reduction factors). Traffic crash data collection, identification of hazardous locations, and engineering study procedures will also be discussed. Emphasis is placed on low-cost solutions that may be made at the local level.

Modern Chip Seal Techniques

May 2, Shoreline; May 3, Moses Lake; May 4, Tacoma; May 5, Vancouver; May 10, Kennewick. (Shoreline, Moses Lake, and Tacoma classes are full.) **\$50.** Instructor: Phil Barto, P.E., retired Spokane Co. Operations Engineer. This course will cover: asphalt chemistry, the purpose of chip sealing, asphalt and aggregates for chip sealing, design, supervising the chip seal crews, equipment preparation, calibration and maintenance, constructing a chip seal, weather conditions, and cost management.

Pavement Condition Rating Workshop

May 10-11, Ellensburg; May 24-25, Tacoma; September 13-14, Tacoma. **Free.** Instructor: Bob Brooks, WST2 Pavement Engineer. Participants will learn to rate any of the pavements commonly found in Washington. The rating values obtained using the definitions and methods learned in this course should compare favorably with those obtained and used in the Washington State Pavement Management System. Each participant should be able to perform a pavement condition survey with reasonable objectivity.

Preparing Your ECS for NEPA Approval

September 22, Tumwater; October 4, Spokane; October 5, Yakima; October 19, Vancouver; November 1, Shoreline. **Free.** Instructors: Brian Hasselbach, John Heinley, Trevin Taylor, WSDOT H&LP Environmental Staff. This course will give a basic understanding of the National Environmental Policy Act (NEPA) and other environmental procedures. The course will predominantly focus on a step-by-step explanation of the Environmental Classification Summary (ECS) – the process and documentation requirements associated with each environmental consideration; the triggers for analysis; and the appropriate responses and level of documentation needed to obtain FHWA's approval. The course

will also provide updates to any process, regulatory, and guidance changes that have occurred in the past year.

Purchasing, Bidding and Contract Management for Local Agencies

May 5, Spokane; May 26, Arlington; September 14, Tacoma; October 4, Yakima (at APWA Conference); November 16, Kent. **\$75.** Instructors: John Carpita, Municipal Research & Services Center of Washington, K. Wendell Adams, City of Yakima, and Dick Andrews, Perteet, Inc. Topics to be discussed:

- Purchasing and bidding overview – statutes that affect local agencies in purchasing goods, materials and services.
- Public works contracting – procedures, checklists, files; contract documents; bidding and contract award issues; contract administration and closeout; retainage and bonding; sales and use tax issues; exemptions; small works projects; emergency contracts; prevailing wage issues; contractor licensing, bond and insurance requirements.
- Consultant selection – types of consultants; quality-based selection vs. bids; selection process; contract negotiations.

General River Mechanics for Highway Design

May 2-6, Lacey; June 20-24, Spokane. **\$320.** Instructors: WEST Consultants, Inc. This course is an introduction to mechanics of fluvial systems. Participants will study the interaction between geology, hydrology, and hydraulics to develop an understanding of how and why river systems erode the land around them. Using this information, methods of managing and correcting stream bank erosion are described. Methods of controlling erosion that have minimal negative impact and sometimes even beneficial impact on the transportation engineers.

Safe Routes to School Training

May 9, SeaTac. **Free.** Sponsored by the Bicycle Alliance of Washington and WSDOT Highways & Local Programs. This training will help communities create effective programs that are based on community conditions, best practices, and responsible use of resources by combining safety, health, and transportation issues. The program focuses on how to identify barriers and create action plans that use a combination of strategies such as teaching pedestrian and bicycle safety, building sidewalks, working with law enforcement to slow traffic, and initiating walking clubs and contests.

Superpave Academy

May 2-5, May 23-26, Wenatchee; June 20-23, Vancouver. (May classes are full, June class still available.) \$300. Instructors: Tim Moomaw and Mike Dellinger, WSDOT Region Trainers. Classes will be at the WSDOT Materials Labs in Wenatchee and Vancouver. The academy is designed for the transportation technician or engineer who is interested in attaining knowledge of Superpave mix design, testing of hot mix asphalt and aggregate properties. The course will provide the necessary knowledge to become a qualified tester in the required test methods. Participants will acquire knowledge and skills in the following areas:

1. Terms and acronyms associated with Superpave volumetric properties
2. Superpave mix design process and aggregate stockpile blending ratio
3. Plotting and interpretation of the FHWA 0.45 power gradation chart
4. Introduction to test methods for acceptance of Hot Mix Asphalt
5. Demonstration and hands on of Superpave gyratory compactor
6. Standardization of forms for use in volumetric calculations
7. Evaluation of volumetric properties

WSDOT Design and Construction Courses

Thirteen WSDOT courses are available for local agency attendance in the Design and Construction disciplines; they are listed below. Attendance is limited to cities, counties, ports, tribes, transit agencies, and consultants acting as official city engineer. Classes are free.

Design Training Season is September through March

- Roadside Safety (B74)
- Managing Project Delivery (B71)
- WSDOT Interchange Design (CFU)
- Intersection and Pedestrian Design (CBD)
- Roadway Geometric Design (BWE)

Construction Training Season is January through May

- Excavation and Embankments Inspection (AC3)
- Nuclear Gauge Safety and Operation (ALG)
- Nuclear Gauge, Embankment/Surfacing/Pavement Applications (ANQ)
- Electrical-Illumination and Signals (API)
- Drainage Inspection (ACF)
- Hot Mix Asphalt Placement (ACB)
- Bridge and Structures Inspection 201 (CQ9)
- Bituminous Surface Treatment Inspection (ACC)

These courses have multiple sessions offered during the training season and are held in Seattle, Olympia, Vancouver, Wenatchee, Yakima, and Spokane. Local agencies are given 20 percent of the seats in each of the classes. If you are interested in any of these courses, check the WST2 web site for availability. A link to course descriptions can be found at the web site.

WSDOT Construction Training Special Offerings

- Electrical-Illumination and Signals (API)
October 12, Spokane; November 8, Tumwater.
- Excavation and Embankments Inspection (AC3)
Watch our web site for dates and locations.
- Hot Mix Asphalt Placement (ACB)
Watch our web site for dates and locations.

Endangered Species Act 4(d) Training Program

The Regional Road Maintenance ESA Training Program courses offered by the University of Washington through June 30, 2005, include:

- **Track 3B: Field BMP Training for Bridges Consistent with NPDES (NEW COURSE)**
1 day, 0.7 CEUs. Registration fee is \$125 for local agency employees in Washington State; \$175 for WSDOT employees. This one-day field demonstration and applications course is designed for local and state bridge maintenance personnel. Participants will learn the proper use of approved materials and BMPs for routine maintenance activities associated with cleaning and painting roadway bridges that pass over or are close to rivers, streams, and other waterways. The material covered in this course conforms to NPDES and ESA.

- **Track 3F: Road Maintenance Crew Training in the Field Environment: Applying Maintenance BMPs**
1 day, 0.7 CEUs. Registration fee is \$125 for local agency employees in Washington State; \$175 for WSDOT employees. This field-based course was designed specifically for maintenance supervisors, crew leads, and crew members. It is conducted in a field setting. Track 3F provides a unique opportunity to learn about, install, and test a variety of BMPs. Participants are divided into teams and work with various types of silt fences, check dams, mulches, matting, and live staking. Many of the BMPs are tested with water to simulate, as closely as possible, actual conditions that would be encountered in the field.

The University of Washington's Transportation Professional Development Program in the Department of Civil and Environmental Engineering and the UW Engineering Professional Programs coordinate and present the training program in collaboration with the WSDOT T2 Center and the Regional Road Maintenance ESA Program Regional Forum Training Subcommittee. For more information, contact Julie Smith, Program Manager, at (206) 543-5539 or by e-mail at jsmith@engr.washington.edu

Current class schedules and additional information can be found at <http://www.engr.washington.edu/epp/esa/reginfo.html>

Further information on this program and the guidelines can be viewed at <http://www.metrokc.gov/kcdot/roads/esa/index.cfm>

TRANSPEED University of Washington

Contact: Christy Pack
(206) 543-5539, toll free 1-866-791-1275
fax (206) 543-2352
<http://www.engr.washington.edu/epp>

Associated General Contractors Education Foundation

Contact: Beth Sachse
(206) 284-4500, fax (206) 284-4595
bsachse@agcwa.com
<http://www.constructionfoundation.org>

To register for a class in this section, use the contacts listed above.

The prices in this section are for local agency / non-local agency.

Traffic Engineering Operations

May 9-11, Seattle. \$320/\$520

Traffic Signal Timing

May 16-17, Seattle. \$300/\$500

Rehabilitation of Pavements

May 16-18, Lacey. \$320/\$520

Construction Inspection of Public Works Projects

May 23-24, Seattle. \$370/\$520

Managing Environmental Impact for Design and Construction

May 24-25, Lacey. \$385/\$600

Public Works Construction Project Management

May 25-26, Seattle. \$370/\$520

Urban Street Design

June 1-3, Lacey. \$320/\$520

Measuring Project Performance

(with a web-based component)
June 2, Seattle. \$555/\$750

Basic Highway Capacity for Engineers and Planners

June 6-8, Seattle. \$320/\$520

Administering Consultant Contracts

June 14, Vancouver. \$175/\$320

Manual on Uniform Traffic Control Devices

June 15-17, Lacey. \$320/\$520

To register for a class in this section, use the contacts listed above.

Construction Site Erosion and Sediment Control Certification

These WSDOT approved classes are presented by the AGC Education Foundation and available on the following dates:

May 27, Tacoma; June 28, Seattle. Certification and recertification training on the same day. \$225/\$250.

Other Training Programs for Local Agencies

Engineering Professional Programs (EPP)

University of Washington
(206) 543-5539
Engineering Refresher Courses
<http://www.engr.washington.edu/epp>

Professional Engineering Practice Liaison (PEPL)

University of Washington
(206) 543-5539
<http://www.engr.washington.edu/epp>

Washington Environmental Training Center

Green River Community College, Auburn
1-800-562-0858
<http://www.greenriver.edu/wetrc>

Click, Listen and Learn

American Public Works Association
(816) 472-6100
<http://www.apwa.net/education/cll/>

Washington State Emergency Management Division

(253) 512-7048 or (253) 512-7000
<http://emd.wa.gov/>

Washington State Department of Personnel (DOP)

Human Resource Development Services
(360) 664-1921
<http://hr.dop.wa.gov/training>

Evergreen Safety Council

(206) 382-4090 or 1-800-521-0778
<http://www.esc.org>

AASHTO Roadside Design Guide, Web-based Training

NHI Course Number: 380032C

This web-based course is approximately 14 hours long and is available anytime — 24 hours, 365 days a year via the Internet. The cost for non-FHWA employees is \$230 per participant and includes a copy of the 2002 AASHTO "Roadside Design Guide." This course provides an overview of the 2002 AASHTO "Roadside Design Guide." Emphasis is on current highway agency policies and practices. Participants must register online at <http://www.nhi.fhwa.dot.gov/registerdl.asp>

Computer Requirements: You will need a fairly recent version of a browser (such as Internet Explorer 4 or 5 or Netscape 4 with JavaScript enabled), the latest version of Macromedia Shockwave and Flash (which you can download from the Internet), and a connection to the Internet (at least 56K modem). An older computer such as a Pentium 100 would work, but it would be slower than a Pentium III. For more information, visit <http://www.nhi.fhwa.dot.gov>

Roadway Safety Conference

September 2005, SeaTac.
For information, contact Matthew Enders
at (360) 705-6907 or EndersM@wsdot.wa.gov.

Road and Street Maintenance Supervisors' Conference

East: October 4-6, 2005, Spokane
West: December 6-8, 2005, Bellevue
For information, contact Michelle Johnson,
Washington State University, at mlj@wsu.edu.

APWA Fall Conference

October 4-7, 2005. Yakima Convention Center.
Contact Person: Wendy Leinan at (509) 575-6068
or Dick McKinley at (360) 676-6961 for information.

Northwest Pavement Management Association (NWPMA) Conference

October 17-20, 2005, Vancouver.
For further information, contact Bob Brooks
at (360) 705-7352 or BrookBo@wsdot.wa.gov.

2005 Summer Employment On-line Student Referral Program

Does your agency need extra help in the summer with construction projects, flagging, surveying, inspection, support for engineers and technicians, drafting, traffic counting, office support, inventorying, recordkeeping, and more? Help an engineering student secure employment this summer by letting them know of jobs available in your agency.

The WST2 Center provides an on-line summer employment referral service to benefit local agencies and college students enrolled in civil engineering or other technical fields. Over the years, hundreds of jobs have been posted to this web site for students in colleges and universities from around the state to access. Currently available jobs are posted at this web site:

<http://www.wsdot.wa.gov/TA/T2Center/StudentReferral/> (select "view current jobs")

If you will have jobs available this summer, go to the web site and select "Local Agency Form." Fill out the form and mail or fax it to the WST2 Center. If you are a college student, you can expect that jobs will begin to be posted starting in March 2005. You should check back often, as jobs will be posted for several months. If you have questions about this program, contact Laurel Gray at (360) 705-7355 or grayl@wsdot.wa.gov.

Tips on Team Motivation

Following are edited suggestions on how to motivate your employees that were provided at the "Motivating Your Team" workshop conducted as part of the Washington State Quality 2000 Conference.

Acknowledgement

- Saying, "thank you."
- Give praise.
- Write a quick personal note.
- A little chocolate and caffeine goes a long way.
- Have a great celebration.
- Appreciate publicly.
- Recognize efforts immediately.
- Give a free T-shirt.
- Have a picnic.
- Give consistent feedback.
- Make appreciation personal and meaningful.
- Post recognition letters on the bulletin board.
- Give recognition to others that you would like to receive yourself.
- Celebrate anniversaries within the agency.
- Provide acknowledgement in your newsletter.
- Give a friendly "good morning."
- Give support and backing to your employees.

Staff Inclusion

- Develop with your employees, a vision statement or theme that shows how your employees' work makes a difference. Publish the vision in your workplace.
- Have monthly "all-staff" meetings.
- Share information.
- Let employees see results.
- Ask for employee input.
- When you do meet with staff, be "present."
- Spend one-on-one time with employees.
- Give employees time to share concerns and rejoice.

Communicate

- Clarify expectations.
- Give open, honest communication.
- Listen.
- Give employees your full attention.
- Respond to questions promptly.
- Work in teams.

Find Out What Motivates Your Staff

- Match talents with jobs of the team.
- Discuss their careers with them.
- Be sincere about employees' well being.
- Make motivation personal.
- Look for opportunities to establish rapport.
- Walk around and get to know your employees.
- Trust what employees tell you about their needs.

Empowerment

- Let assistants manage something.
- Provide independence.
- Give employees tools to do their job and then give feedback.
- Provide a flexible, positive work environment.
- Trust your employees.
- Allow employees to build quality into their work.
- Provide training.

Start With Yourself

- You may need to get out of your comfort zone.
- Show your own enthusiasm and motivation for being there.
- Love the work you do.
- Believe in yourself and know that you have a purpose.

Trust

- Treat each employee fairly and equally.
- Respect and trust.

Fun

- Provide opportunities for laughter.



To ride or not to ride, walk or not to walk.....
Thank-you Gordy Hyde, Snohomish County Public Works,
for the picture.



Sign of the Times

Do you have a humorous traffic sign to share? Send us a print or e-mail a digital image (preferably a 300 dpi, 1000x1500 dpi jpeg or tif) and we will add it to our collection for publishing. Please provide your name, title, agency or company, and a short description of where and when you saw the sign. We want to give you credit for your participation.

You can e-mail the image to schofil@wsdot.wa.gov

Or mail the photo to:
"Sign of the Times"
WST2 Center
PO Box 47390
Olympia, WA 98504-7390

Please don't send your original photo. Although we will do our best to return the photo, we can't guarantee it.

You can receive the WST2 newsletter electronically by adding your e-mail address to the WST2 Newsletter Listserv at <http://www.wsdot.wa.gov/TA/T2Center/T2HP.htm> You can also view the newsletters at the same web address beneath the heading "Publications & Software".

If you would like to stop receiving a hardcopy of the newsletter, please e-mail Wendy Schmidt at schmidw@wsdot.wa.gov, or phone (360) 705-7386, and ask to be taken off the hardcopy mailing list.

Mousetrap Registration

Name of Invention: _____

Agency: _____ (WSDOT) Region: _____

Mailing Address: _____

City: _____ State _____ Zip+4: _____

Contact Person: _____

E-mail Address: _____

Phone: () _____ Fax: () _____

Inventor(s)/Fabricator(s): _____

E-mail Address: _____

Phone: () _____ Fax: () _____

Supervisor's Name: _____

What prompted this invention (or equipment modification)?

How was it developed?

Labor, Equipment, Materials Used (from scrap pile? Did you purchase any parts?):

Cost Estimate (a rough guess will do):

Benefits to your operations:

Include sketches or plans of your "Better Mousetrap" with dimensions and materials identified, and photographs of the item from all angles (front, top, side, etc.) with the inventors in the photo if possible, to:

Build a Better Mousetrap
WSDOT-WST2 Center
PO Box 47390
Olympia, WA 98504-7390

For more information and photos of Mousetraps and Expo, check the Washington State T2 Center's web page:
www.wsdot.wa.gov/TA/T2Center/t2hp.htm
or contact Wendy Schmidt at (360) 705-7386 for details.

You can now register your Mousetrap online at: <http://fmapps.wsdot.wa.gov/mousetraps/Register.htm>



Washington State Technology Transfer Center
WSDOT – H&LP Division
PO Box 47390
Olympia, WA 98504-7390

PRSR STD U.S.POSTAGE PAID Washington State Department of Printing
