

WST2

Washington State Technology Transfer



Dollars & Days: Innovative Project Delivery through A+B Bidding pg 5

Local Government Funding – Streamlined Sales Tax Project pg 10

Automated Real-Time Road Weather System (ARROWS) pg 20



**Washington State
Department of Transportation**

A Technical Digest of the
Washington State Department of Transportation (WSDOT)
and the Local Technical Assistance Program (LTAP)

Issue 81, Winter 2004

Washington State Technology Transfer

WST2 Washington State Technology Transfer

is published quarterly without fee in
February, May, August, and November

by WSDOT Highways & Local Programs
Washington State Technology Transfer Center
310 Maple Park Avenue SE
PO Box 47390
Olympia, WA 98504-7390

E-mail: WST2Center@wsdot.wa.gov
Home Page: <http://www.wsdot.wa.gov/TA/T2Center/T2hp.htm>

Requests for subscriptions, change of address, and other subscriber services should be addressed to schmidw@wsdot.wa.gov, or phone (360) 705-7386, or WST2 Center, PO Box 47390, Olympia, WA 98504-7390. Subscriptions are distributed free of charge.

Issue 81, Winter 2004

POSTMASTER:

Please send address changes to WST2,
PO Box 47390, Olympia, WA 98504-7390

Include both old label and new address.



Article contributions, questions, or comments are welcome.
Please contact Larry Schofield, P.E., Technology Transfer Engineer,
PO Box 47390, Olympia, WA 98504-7390; phone (360) 705-7380,
fax (360) 705-6858, or e-mail schofil@wsdot.wa.gov.

Editor reserves the right to refuse to publish and to edit articles
to conform to the standards of our publication.

The opinions expressed in articles are not necessarily those
of the editor.

Cover Photo: *Cover photo by Roger Chappell:
Previously held Pacific Northwest Transportation
Technology Expo. Note: The 2004 Pacific Northwest
Transportation Expo will be held May 18-19, 2004,
at the Grant County Fairgrounds, Moses Lake,
Washington. Make your plans to participate.*

Contents

F rom the Editor's Desk	3	B TEP	24
T echnology News	4	Rocky Mountain Maintenance Workshop	24
Locally Produced Pedestrian Safety Video in the Works	4	W SDOT Library	25
A rticles	5	Hot Topic – Relationship Between Speed and Crash Risk	25
Dollars & Days: Innovative Project Delivery through A+B Bidding	5	R oger's Technology Toolbox 2004	27
Studded and Studless Tire Traction and Safety – Giving Credit Where Credit's Due?	5	If a Picture is Worth a Thousand Words, What is a "Smart Image" Worth?	27
Local Government Funding – Streamlined Sales Tax Project	10	W ST2 Resources	29
M ousetraps	13	O nline Resources	30
Marvin Cox and Ken Shave's RV Dump Inlet Restrictor Rod	13	T raining Opportunities	32
WSDOT Olympic Region Button Truck	15	C onferences	38
W SDOT Research Office	19	S ign of the Times	40
State Pavement Technology Consortium	19		
Automated Real-Time Road Weather System (ARROWS)	20		
N WPMA News	21		
Words from the Chair	21		
U SDOT FHWA/NHTSA	23		
News from FHWA Washington Division	23		
New FHWA Office of Safety Geometric Design Program Web Site	23		

Subscribe to WST2 Listservs

The WST2 Listservs allow you to retrieve messages from and post messages to a network of mailing lists. There are five Listservs available through the WST2 Center:

■ Pavement Technology Listserv

Internet Address:

http://T2Pave-L@lists.wsdot.wa.gov/guest/RemoteListSummary/T2PAVE_L

E-mail Address: T2PAVE-L@lists.wsdot.wa.gov

Receive periodic technical information on pavement technology and local agency pavement management information, including Northwest Pavement Management Association (NWPMA) information and any late breaking technical information and announcements.

■ Traffic Safety and Technology Listserv

Internet Address:

http://T2SMS-L@lists.wsdot.wa.gov/guest/RemoteListSummary/T2SMS_L

E-mail Address: T2SMS-L@lists.wsdot.wa.gov

Receive information and resources covering the latest in traffic technology, traffic safety, roundabouts, safety management, and safe communities.

■ WST2 Center Training Listserv

Internet Address:

http://T2TRNG-L@lists.wsdot.wa.gov/guest/RemoteListSummary/T2TRNG_L

E-mail Address: T2TRNG-L@lists.wsdot.wa.gov

Receive the quarterly Educational Opportunities and other training information and resources available through the WST2 Center.

■ Training Resource and Information Network Listserv

Internet Address:

http://TRAIN-L@lists.wsdot.wa.gov/guest/RemoteListSummary/TRAIN_L

E-mail Address: TRAIN-L@lists.wsdot.wa.gov

The acronym TRAIN stands for Training Resource And Information Network. TRAIN is a network of interagency training departments in Pierce, Thurston, and Kitsap Counties sharing training resources. This site will be used to post news about TRAIN and to post training opportunities and available classes for agencies within the three counties.

■ WST2 Newsletter Listserv

Internet Address:

http://T2News-L@lists.wsdot.wa.gov/guest/RemoteListSummary/T2News_L

E-mail Address: T2News-L@lists.wsdot.wa.gov

This listserv distributes the WST2 newsletter, a quarterly periodical dedicated to covering a wide range of technical topics to assist Washington State communities and local governmental agencies. This listserv is for distribution purposes only.

To subscribe to any of the WST2 Listservs, follow these procedures:

1. Type the Internet Address of your chosen listserv in your Internet browser address line and enter.
2. Type your e-mail address, select Immediate Delivery, and click the Submit button. You can ignore the Request to Response screen. *Note:* If you wish to unsubscribe from a listserv, enter your e-mail address, select Unsubscribe, and click the Submit button.
3. When you receive e-mail from the listserv requesting address verification for subscription, select reply, and send; there is no need to enter any text in the reply message. You will receive confirmation e-mail and a welcome message from the listserv to which you subscribed.

To post a message to a listserv, type the e-mail address of your chosen listserv in the e-mail address field, type your message, and send. Your message will be sent to everyone subscribed to that particular listserv.

WST2 Center Listservs are the ultimate information exchange tool. Enjoy!

From the Editor's Desk



Brian Walsh, P.E.
Technical Services Manager,
WSDOT Highways &
Local Programs

Some of you may recall my face from an earlier version of the WST2 Newsletter (Spring 2002) when I was introduced to the local agency community as Washington State Department of Transportation's (WSDOT) Local Traffic Services Engineer. I now welcome the chance to strengthen my relationship with each of you and set forth on the steep learning curve as the recently appointed Technical Services Manager with responsibility and oversight of the WST2 Center.

As Technical Services Manager, I will proudly lead the WST2 Center, which achieved national acclaim under the able management of Dan Sunde, former Technology Transfer Engineer, and Kathleen Davis, our Director of Highways

and Local Programs. I will be very involved with Local Technical Assistance Program issues nationally and here in Washington State.

In addition, my duties will include supervising the Local Agencies Traffic Services group, which is not only responsible for providing traffic engineering services to local agencies (at the time of this printing, we are in the process of filling the Traffic Engineer position) but also for managing bike and pedestrian issues and promoting implementation of local safety initiatives statewide. As Technical Services Manager, I am also responsible for promoting *Building Projects that Build Communities* efforts, not only for their effect on safety and mobility but also for their effect on the aesthetic, social, economic, and environmental values within a broader community setting.

To tell you a little about myself, I came to WSDOT in 1991 by way of Montana, California, and Virginia, where I was involved in numerous transportation projects, particularly traffic signal systems and traffic related services to communities. Prior to 2002, my duties at WSDOT were focused on state highways that pass through communities and how to positively impact safety by having engineers collaborate with the enforcement and educational elements of traffic safety. I am open to innovations that make our roads safer and more efficient, and I champion ideas that have the best chance of success. Roundabouts come to mind as a recent example. Washington State did not have a single "bona fide" roundabout until 1997, and now there are 48 roundabouts on city, county, and state roadways. I promise to identify innovative ideas and apply the same kind of championing on other technology transfer issues.

I look forward to meeting you and working with your agency and FHWA staff in the next few months to continue this journey of improving our lives through the transfer of technology. If my e-mail has been any indication of the support I will have in doing this task, I am in for a treat. You recognize how important the WST2 Center is in the wider context of technology transfer and it is with a humble hand that I take part in this adventure of leading the WST2 Center.

Secretary of Transportation
Douglas B. MacDonald

Chief of Staff
Paula Hammond, P.E.

**Highways & Local Programs
Director**
Kathleen Davis

Engineering Services Manager
Michael Horton, P.E.

**Technical Services Manager &
Managing Editor**
Brian Walsh, P.E.

Technology Transfer Engineer
Larry Schofield, P.E.

Publishing Editor
Kimberly Colburn

Assistant Editor
Wendy Schmidt

Graphic Design
WSDOT Graphics

Staff Writers
Bob Brooks
Roger Chappell
Laurel Gray
Dave Sorensen

The Local Technical Assistance Program (LTAP) is a national program financed by the Federal Highway Administration (FHWA) and individual state transportation departments. Administered through Technology Transfer (T2) Centers in each state, LTAP bridges the gap between research and practice by translating state-of-the-art technology into practical application for use by local agency transportation personnel.

Any opinions, findings, conclusions or recommendations presented in this newsletter are those of the authors and do not necessarily reflect the views of WSDOT or FHWA. All references to proprietary items in this publication are not endorsements of any company or product.

 **Washington State
Department of Transportation**

 **U. S. Department of Transportation
Federal Highway Administration**



By *Dave Sorensen, Traffic Technology Engineer, WSDOT Highways & Local Programs*

City of Olympia officials recently approached Washington State Department of Transportation (WSDOT) Highways and Local Programs (H&LP) and the Washington Traffic Safety Commission (WTSC) to co-produce a short video on pedestrian safety. This project is a public education approach to addressing the rising incidence of pedestrian/vehicle collisions.

Locally Produced Pedestrian Safety Video in the Works

In 2003, the City of Olympia began broadcast of the production "Driving Modern Roundabouts" on local cable access. The 10-minute video was co-produced by WSDOT H&LP, WTSC, and the cities of Lacey and Olympia. The video captured national attention by winning a Telly Award and is currently being broadcast in other Washington localities and in other states.

"We hope to have the same success with the pedestrian video," said Sophie Stimson, City of Olympia planning department.

"Public awareness of pedestrian safety issues must be improved if we truly are going to get to zero fatalities in Washington," said Lynn Drake, WTSC pedestrian safety program manager.

Anticipated completion of the pedestrian safety video is scheduled for spring 2004.

▲
For more information, contact Dave Sorensen at (360) 705-7385 or sorensd@wsdot.wa.gov.

Winter Driving Tip

By *Dave Sorensen, Traffic Technology Engineer, WSDOT Highways & Local Programs*

You've seen them. They're out there. Are you one of them? The drivers that just don't have time to let the car defroster finish its job before getting on the road. They are easy to recognize with only a dinner plate sized spot of their windshield defrosted. Obviously, with such limited visibility, this is a very dangerous way to drive. Well, if you are one of those drivers, here's a tip: **before you drive, fold your sun visor down close to the windshield and turn the defroster on.** Doing this creates a dam, trapping the warm air from your defroster against the glass and dramatically reducing the defrost time.

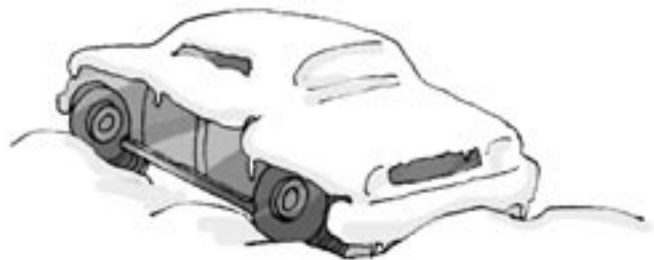

Dollars & Days: Innovative Project Delivery through A+B Bidding

By Dave Becher, WSDOT Access Downtown Construction Project Engineer and Laura Johnson, WSDOT Access Downtown Communications Specialist

The NE 4th/NE 6th Bellevue Direct Access Project (Contract 6549) is the last, largest, and most complicated of the \$164 million package of projects called Access Downtown. These projects are designed to improve access to and from I-405 in Bellevue, Washington.

The NE 4th/6th project:

- Reconstructs the NE 4th bridge over I-405.
- Realigns the northbound and southbound I-405 ramps at NE 4th.

- Realigns the northbound and southbound collector-distributor lanes.

- Realigns the ramps at the NE 8th Street interchange.

All of these improvements are necessary to build the new direct access HOV ramp at NE 6th Street, for improved access to downtown Bellevue, and the newly completed Bellevue Transit Center. Access Downtown is a partnership between Sound Transit, Washington State Department of Transportation (WSDOT), the City of Bellevue, King Country Metro, the Federal

Highway Administration, and the Transportation Improvement Board.

The NE 4th/6th project is a complicated operation right through the heart of Bellevue. The project partners determined early in the planning process that delivery of this project couldn't be business as usual. Our partners at Sound Transit and the City of Bellevue wanted the NE 6th direct access ramp to be open to traffic by the end of 2005.

To ensure that we could meet this ambitious timetable, the design team, led by WSDOT

Continued on page 6.

Studded and Studless Tire Traction and Safety – Giving Credit Where Credit's Due!

By Dan Sunde, P.E., Assistant Director, WSDOT Project Control & Reporting Office

In reference to the article titled "Studded and Studless Tire Traction and Safety" in Issue 80, Fall 2003 of the WST2, some very important information was unintentionally omitted. The article summarizes research conducted at the University of Washington by Robert R. Scheibe. The report is titled *An Overview Of Studded And Studless Tire Traction And Safety* and is published by the Washington State Department of Transportation (WSDOT) Research Office as report number WA-RD 551.1. A brief description of the report can be found at <http://www.wsdot.wa.gov/Research/OnePages/WA-RD5511.htm>. If you'd like a copy of the report, contact Sarah Smith, WSDOT Research Office, at smithsa@wsdot.wa.gov or (360) 705-7971.

Our apologies to Robert Scheibe and the WSDOT Research Office for the oversight.

Also, there has been confusion about two statements in the "Traction Performance" section of the article. In the first paragraph, the statement "Overall, the *all season* [emphasis added] tires performed significantly worse in virtually every stopping-distance test on packed snow and ice..." refers to an all season radial tire, one of three types of tires rated. The statement "As a result, *non-studded winter* [emphasis added] tires perform better than studded tires on snow and ice..." refers to a second type of tire rated, a snow tire without studs added. These are two different tires as stated earlier in the second paragraph of the "Purpose" section of the original article. I hope this helps clarify the difference.

Access Downtown Design Project Engineer Denise Cieri's project office, along with the lead design consultant, HDR, explored various delivery options to ensure project completion by the end of 2005.

Project Delivery Options

As the design progressed, five different project delivery options were considered:

- **Standard Working Days:** Working days are typically defined as Monday through Friday, with the exception of holidays as defined by the *Washington Standard Specifications for Road, Bridge, and Municipal Construction*. Non-working days are granted for inclement weather that impacts critical path work activities. Engineers determined quite early in the process that this standard contracting method would likely not result in a December 31, 2005, project completion. The number of standard working days that the design and construction offices estimated for the project kept pushing the completion date into 2006.
- **Completion Date:** Engineers discussed the idea of just setting a December 31, 2005, completion date to ensure that the project would be completed by the end of 2005. While simple in concept, the actual implementation is much more complicated. Delays, plan errors, change orders, construction engineering errors, third-party impacts, and other factors could make meeting a December 31 date difficult for the contractor or very expensive to the project partners.
- **Every Day a Working Day:** A third idea engineers considered was to charge working days seven days a week, forcing

the contractor to work at an accelerated pace. Designers determined that a seven-day-a-week schedule would allow completion by the end of 2005. However, this option was considered very risky because it doesn't allow any schedule time (weekends) to recover from delays, plan errors, construction engineering errors, change orders, or third-party impacts.

- **Incentives for Project Completion:** Another option engineers reviewed was to set a project completion date *before* December 31, 2005, and provide substantial contract incentives to meet this date. This option has many of the same drawbacks as the previous ideas (schedule recovery issues, third-party impacts, change orders, etc.) and carries the additional risk of the partners having to pay the entire bonus to the contractor due to impacts and still not meet the December 2005 completion date.
- **A+B Bidding:** A fifth option was for the contractors to bid both the actual work costs ("A") and the time component of the project, which is given a monetary value ("B"). While this approach still has some of the problems of the previous options (plan errors, schedule recovery, third-party impacts), it does have a significant benefit in that the contractor verifies the number of working days that WSDOT estimated for the project. One drawback with the A+B option is that initial bids could come in higher than for a standard working day schedule contract approach, due to the potentially accelerated nature of the construction. In addition, if all bidders came back with the number of days set up by the department, we would know that the construction project schedule is extremely tight.

A+B Bidding Process

After extensive review and discussion, WSDOT decided to use A+B bidding on the NE 4th/6th project. A modified version of the A+B bidding was used, with four "B" interim completion milestones defined in the contract.

Each of the interim milestones was assigned a number of baseline working days and a dollar value (user benefit) (see Table 1). The user benefits were used purely to determine the low bidder; they did not represent the final dollar value of the contract. The total contract time is defined as B3 + B4, or 613 working days. (The B1 and B2 milestone work would occur at the same time as the B3 work.)

To determine the low bidder, the contractors bid both the contract work (various bid items) and the working days for the four interim milestones (see Table 2). The contractors could use the number of working days set up in the contract, or they could reduce the number of days. They could not increase the number of working days. The low bidder was determined based on the actual bid amount plus the milestone component.

Atkinson Construction was the low bidder, and they were awarded the contract for the NE 4th/6th project. Their bid of 369 working days was a remarkable 244 working days less than the number of days estimated during the design process. Atkinson's bid was based on an extensive review of the project phasing and on plans to utilize some very innovative construction techniques to expedite the work.

It is interesting to note that Atkinson was the low bidder on both the A and B components. The second low bidder (Kiewit) actually had the third highest A component, but their B component pushed them into the runner-up position.

TABLE 1. Interim (“B”) Milestones for the I-405 / NE 4th/6th Bellevue Direct Access Project			
Milestone	Baseline Working Substantial Completion of:	Dollar Value Days for Completion	(User Benefit)
B1	Improvements to NE 8th/112th Intersection	70	\$2,500/day
B2	NE 4th Structure (opening to east/west traffic)	244	\$10,000/day
B3	Southbound NE 4th On/Off Ramps (opening to traffic)	471	\$10,000/day
B4	NE 6th Direct Access Ramp	142	\$10,000/day

TABLE 2. A+B Bidding Results for the I-405 / NE 4th/6th Bellevue Direct Access Project				
Contractor	Atkinson Construction	Kiewit Construction	Balfour Beatty	Mowat Construction
Base Bid	\$44,159,049	\$46,390,887	\$45,896,266	\$48,675,999
B1 (days x \$2,500)	\$75,000 (30 days)	\$170,000 (68 days)	\$175,000 (70 days)	\$125,000 (50 days)
B2 (days x \$10,000)	\$1,170,000 (117 days)	\$1,920,000 (192 days)	\$2,440,000 (244 days)	\$2,440,000 (244 days)
B3 (days x \$10,000)	\$2,580,000 (258 days)	\$3,860,000 (386 days)	\$4,710,000 (471 days)	\$4,710,000 (471 days)
B4 (days x \$10,000)	\$1,110,000 (111 days)	\$1,150,000 (115 days)	\$1,420,000 (142 days)	\$1,420,000 (142 days)
A + B	\$49,094,049	\$53,490,049	\$54,641,266	\$57,370,999
Working Days	369	501	613	613

Risks of A+B Contracting

There are a number of risks associated with A+B bidding that, while not specifically unique to this type of contracting, are increased due to the accelerated nature of this type of project.

- **Artificial Milestones:** Having too many interim milestones can make construction administration difficult, and setting milestones that aren't part of the critical path can divert resources from more critical operations.
- **Plan Errors:** Because of the accelerated construction schedule, any errors, change orders, etc., could result in costly impacts to the schedule (schedule recovery time or the granting of additional contract time, which could result in

increased cost due to extended overhead). As a result, it is very important to have a detailed, carefully prepared set of contract plans.

- **Construction Administration Errors:** Similar to plan errors, mistakes made in the field by WSDOT personnel could impact schedule quite quickly and result in high costs for schedule recovery or extended overhead. It is important to resolve field issues quickly to prevent impacts.
- **Selection of Contractor:** WSDOT has no control over who the low bidder will be for this type of project. If we get a less experienced contractor or one who is looking to file claims as the low bidder, the prospects of a successful project diminish.

- **Potential for WSDOT/ Contractor Conflict:** This type of fast-track project increases the potential for conflict between contractor and WSDOT personnel. Multiple shifts are often required, and the contractor is likely, at times, to provide little advance notification to WSDOT of certain construction activities due to scheduling issues.
- **Third-Party Impacts:** Delays with utility relocations, private landowners, cities, or other non-WSDOT government organizations can have an immediate and costly impact to an accelerated A+B schedule. Again, these could result in either schedule impacts or costs to recover schedule.

■ **Ability to Deliver Answers:** WSDOT and other agencies have to devote sufficient resources to be able to respond rapidly and efficiently to questions and issues presented by the contractor and to deliver the required support to the project offices. If the department delays the contractor due to slow decision making, impacts and costs will quickly build.

Benefits of A+B Contracting

While there are significant (and potentially costly) risks associated with this method of contracting, there are also significant benefits to the department.

■ **Quick Project Completion:** By allowing the contractor to determine the number of working days for the project, we improve the ability to deliver the project as rapidly as possible, thus reducing overall impact costs to the public.

■ **Schedule Accuracy:** By having the contractor's bid time on the project, the contractor validates (or discovers mistakes in) the WSDOT project schedule for the work.

■ **Contractor's Project Knowledge:** This method of bidding forces the contractor to carefully review the project documents and schedule out their work in advance of the project bid.

■ **Early Prevention of Problems:** Due to advance review and scheduling during the bidding process, the contractor is more likely to identify potential problems early into the project.

■ **Hitting the Ground Running:** The contractor is likely to get off to a more rapid start on the project due to advance review of the project during advertisement.

■ **Administrative Efficiency:** A+B contracting forces WSDOT to become a more efficient organization, able to respond rapidly to a multitude of project issues.

Project Status

At the time of this writing (early December 2003), we are approximately 40 percent complete with the NE 4th/6th project. We expect to complete the B1 and B2 milestones in early December 2003, and we are on track with the B3 milestone (opening the southbound NE 4th ramps), scheduled for completion in late June/early July 2004.

The B1 milestone (NE 8th/112th intersection improvements) has been completed late due to a variety of reasons, many of which are listed under the "Risks" section of this article: third-party impacts (utility relocation), late delivery of state-furnished signal poles, and minor plan errors. There are numerous cost issues associated with this late milestone delivery. However, these cost issues are nominal and more of an administrative issue than one of increased contract cost.

On the other hand, the B2 milestone (NE 4th structure opening to east/west traffic) is finishing only three days later than originally bid

by the contractor. The department granted the contractor a three-day extension due to a record rainfall event in October. The project site received over five inches of rain in a two-day period, halting work.

So far, the A+B contracting method has worked well on this project. The contractor has proposed numerous innovative construction techniques to expedite the work. They have worked multiple shifts and worked closely with both WSDOT and our partners to resolve issues as rapidly as possible. WSDOT and our partners have worked to improve the review and oversight process to respond to the fast-track nature of this project.

A+B Bidding is a contracting method that has merit for certain projects which require a specific completion date. However, due to the risk potential and high level of support required for this contracting method, it should be carefully considered prior to using it on a project.



For more information about the NE 4th/NE 6th project and the other Access Downtown projects, visit the web site at: <http://www.AccessDowntown.com>.



Photo 1 – Looking north up I-405. The overpass closest to the foreground is the old NE 4th Street bridge.



Photo 2 – Again looking north up I-405, in July 2003. In the foreground is the construction area for the new NE 4th Street bridge. On the west (left) side of the freeway, the southbound on- and off-ramps will be rebuilt.



Photo 3 – The NE 4th Street bridge was demolished in June 2003. This shot was taken on July 15, looking southeast.



Photo 4 – Just 18 weeks after the previous shot (again looking southeast), the new bridge is in place and nearly ready to open.



Photo 5 – In September 2003, the future location of the depressed southbound collector-distributor lane is still at approximately the same elevation as the freeway. This shot is looking north from NE 4th, on the west side of I-405.



Photo 6 – A mere 10 weeks later, the bottom of the trench for the new collector-distributor lies approximately 20 feet below freeway level. Columns and footings are being placed in the trench for the new southbound off-ramp.

Local Government Funding – Streamlined Sales Tax Project

By Jim Seitz, Transportation Specialist,
Association of Washington Cities (AWC)

For the past several years, the state of Washington has participated in the Streamlined Sales Tax Project (SSTP), a national effort by a coalition of states to make sales and use taxes simpler and more uniform. Once Washington fully adopts this legislation, it qualifies to join the SSTP governing board, which will decide the rules for future streamlined sales tax provisions.

A desired outcome of the SSTP is to convince Congress to pass enabling legislation allowing states to collect sales or use tax on remote sales (e.g., mail-order, Internet, or television sales by persons with no physical presence in the state). Under the U.S. Supreme Court's ruling in *Quill v. North Dakota* (1992), the Commerce Clause of the U.S. Constitution prohibits states from taxing such sales without the consent of Congress. Under current law, purchasers of goods from remote sellers are responsible for paying use tax, but individual customers rarely know about or pay the use tax voluntarily, and enforcement is impractical. As Internet sales continue to grow, sales and use tax losses to local governments and the state are expected to be substantial.

What needs to happen to implement SSTP in Washington State?

Adopted in the 2003 session, SB 5783 implemented the majority of the Streamlined Sales and Use Tax Agreement provisions with which Washington State did not already comply. Washington conforms to the majority of the

provisions of the model agreement with the exception of the "sourcing rule" (see definition below), which would allocate sales taxes to the place of delivery.

The Department of Revenue plans to introduce 2004 legislation to implement the remaining recommendations of the SSTP. Since passage of SB 5783, due to the potential impacts to local jurisdictions, particularly those with high levels of warehouse delivery, the Department of Revenue has been directed to:

- Study the potential impacts of the sourcing rules on local governments.
- Identify potential mitigation of any significant impacts that could result from implementation.
- Report back to the Legislature in December 2003.

The study has two advisory groups that are staffed by the Department of Revenue and include both city and county representatives. The policy committee continues to meet to analyze the study's preliminary results and to discuss recommendations for mitigation options.

What is the Sourcing Rule?

The SSTP model agreement includes a sourcing rule for allocating local sales tax that differs from the one currently in effect. Under current law, the local sales tax on sales of goods is allocated to the jurisdiction of the retail outlet

at which or from which delivery is made. The SSTP would shift local sales taxes to the place of delivery instead.

In most instances, the customer accepts delivery at the retail outlet, with no practical difference between current practice and the SSTP proposal. However, when goods are delivered to the customer at a separate location, the SSTP proposal would allocate sales tax to the jurisdiction where the customer is located rather than the jurisdiction in which the retailer is located.

In particular, the Department of Revenue identified the potential for substantial shifts in revenues from jurisdictions with businesses that involve delivery of goods to customers in other areas (such as software sales and warehouses that deliver goods like furniture to retail customers outside the jurisdiction).

What would happen if Washington State does not implement the sourcing rule?

The Department of Revenue believes that Washington needs to implement the sourcing rule to comply with the model agreement and to become a member of the governing board, which will decide the rules for future streamlined sales tax provisions. In addition, as a member, Washington State will receive additional sales taxes from remote sellers who have agreed to voluntarily comply with the SSTP, in part to benefit from its tax liability protections.

Under the terms of the SSTP, those retailers will collect sales taxes for every member state that has implemented the model agreement.

What is happening at the federal level?

Earlier in 2003, legislation (H.R. 3184/S.1736) was introduced in the U.S. Congress that would impose sales tax collection requirements on remote sellers (except for small businesses) once 10 states, comprising at least 20 percent of the population of states imposing a sales tax, implement the Streamlined Sales and Use Tax Agreement. For more information on the status of that legislation, search for H.R. 3184 at <http://thomas.loc.gov>.

The member states of the streamlined sales tax project also continue to meet on a regular basis to discuss further steps in streamlining sales taxes. For further information, see <http://www.streamlinedsalestax.org>.

What is next?

This is an extremely important issue for cities and AWC. It also could be very divisive, since survey results have shown some cities as financial "winners" and others as "losers." Obviously, cities will have different positions regarding the implementation of the sourcing rule, which does require legislative action. AWC will continue to closely follow this issue and report on the progress

of the meetings and study results as information becomes available. Per AWC Board direction, we will also be facilitating meetings with "winner" and "loser" jurisdictions to find acceptable mitigation options.



For more information, contact Jim Seitz at (360) 753-4137 or jims@awcnet.org.

Need help with a special project ... need the expertise and experience of a professional?

If your agency is seeking an experienced public works professional, the WST2's Retired Professionals program is for you.

The program provides a listing of retired public works professionals with expertise in the areas of maintenance, operations, engineering, inspection, construction, and surveying, just to name a few. Access the Retired Professionals listing at:

<http://www.wsdot.wa.gov/TA/T2Center/Retired.htm>

If you have questions, contact Laurel Gray at (360) 705-7355 or grayl@wsdot.wa.gov

Retired? Soon to be retired?

Would you like to be part of this program? Give us a call.



How to Be a Better Team Contributor

By Robert Bacal, M.A.

More and more often, employees are expected to contribute to the performance and success of their work teams. While it sounds great on paper, it isn't all that easy to work in a team, since often team members are different in style, attitude, commitment, and work ethic. If you are a work team member, supervise, manage or lead a team, take a good look at these tips and hints which will make it easier for team members to contribute more productively to their teams and decrease friction among team members!

Stop the Blaming Cycle

Often teams get bogged down in blaming members when things go wrong. As a team member, you can do two things to stop this wasteful and destructive team behavior.

First, eliminate blaming language you may use. Replace blaming and finger-pointing comments or questions with a focus on solving problems or preventing problems. Second, if other team members get into the blaming cycle, step in and "turn" the conversation back to a constructive approach. For example, here's a good phrase: "Ok, maybe we could save some time here by trying to ensure that the problem doesn't happen again, so what can we do to prevent it next time?"

Focus on the Present and Future

This is related to the blaming cycle. Don't dwell on the past. Use the past (successes and team failures) to help the team determine where it needs to go to improve. You can't change the past — you can only use it to learn from.

Stop Back Channel Talk

Talking about a team member in private with another team member usually involves a blaming

process. While sometimes it's good to vent frustration about a fellow teammate, you shouldn't be doing it within the team. It's counterproductive and harmful. Stop doing it unless you have a specific, constructive reason for doing so.

Personal Responsibility

Take responsibility for your behavior and the results that your team produces, but NOT the behavior of your teammates. When you take responsibility for another member's actions, you will tend to want to change your teammate, something that often creates dissension.

Finally, focus on YOUR contributions. Don't spend your time thinking about or telling team-

mates what THEY should be doing for the team. Think about what you can contribute and how you can contribute more effectively. Then do it. For example, if you have a great suggestion, don't dump it on the group with the expectation that someone else will implement it. You offer to do it...after all, it's your suggestion.



Robert Bacal is a noted author, keynote speaker, and management consultant. His most recent books include Performance Management - A Briefcase Book, and The Complete Idiot's Guide To Managing Difficult Employees. For more information, contact Robert Bacal at ceo@work911.com or by phone at (204) 888-9290.

Pacific Northwest Transportation Technology Expo

As you get ready for the New Year, don't forget to mark your calendar for the Pacific Northwest Transportation Technology Expo (PNTTE). It will be held at the Grant County Fairgrounds in Moses Lake, Washington, on May 18-19, 2004.

Come and see the latest Mousetraps, innovations, and equipment in road technology, traffic safety, and more. There will be demonstrations of equipment, tools, and materials. The Expo provides the Pacific Northwest transportation professional an opportunity to see the latest research technology, new technologies just arriving on the market, and innovative, homegrown ideas that your peers have developed to make their jobs easier and save their agencies money.



Pacific Northwest
Transportation
Technology Expo

For more information about the Expo, visit the web site at:
<http://www.wsdot.wa.gov/ta/T2Center/TechnoExpo/>

For information about display opportunities at Expo 2004, contact Kelly Newell, WSU Conferences and Professional Programs, at knewell@wsu.edu or (509) 335-3530.

Marvin Cox and Ken Shave's RV Dump Inlet Restrictor Rod

By Dave Sorensen, WSDOT H&LP
Traffic Technology Engineer

For many years, recreational vehicle owners have had the convenience of discharging their holding tanks at highway rest area facilities. One of the challenges the Washington State Department of Transportation (WSDOT) rest area attendants encountered was that the RV dump inlet system habitually became clogged. Specifically, the system was getting plugged with debris such as pop cans, wire, diapers, and, at times, the RV drain hose itself. Typically, an RV has a 4-inch diameter discharge hose. The hose would come loose from the RV during discharge and fall down into the drain system pipe.

During summer peak travel times, if an RV dump site was down at one rest area, there would be increased usage at a nearby rest area and this would overload the system. In the case of a severe

clog, the dump site could be out of service for several days until the maintenance crew could arrange to have a vactor truck clean out the drain system.

Ken Schave and Marvin Cox, WSDOT Southwest Region rest area attendants, had the unenviable job of unclogging the RV drain systems. This meant responding to a problem up to three times a week during summer peak travel. At around \$190.00 a trip, the cost adds up fast. This process also inconvenienced the RV traveling public.

Ken and Marvin came up with a simple, yet ingenious device that virtually eliminated the clogging problem. They installed a recessed 1/4-inch diameter rod inside the dump site drain hole that prevented large debris or an RV drain hose from entering the system. They experimented with various diameter rods and settled on the 1/4-inch diameter as the best design. Since installing this device

in January of 2001 at the I-5 northbound and southbound Gee Creek rest areas, only two clogs have been reported!

The cost of inventing the device, including labor and materials, was a mere \$61. Since installation of the invention, Rick Hazen, WSDOT Southwest Region maintenance supervisor, estimates a direct cost savings of nearly \$3,300 per year. "It used to take up to a half a day to get the dump site system back in service," Hazen said.

Other key contributors to this idea were WSDOT's John Hicks and Dave Nuttman, also from the Southwest Region maintenance office. Congratulations to all on a great idea!

▲
For more information on this invention, contact Rick Hazen, Southwest Region Maintenance Supervisor, at (360) 905-2205 or e-mail at hazenr@wsdot.wa.gov.



Restrictor rod device installed.



RV vehicle discharging.



Device prevents large debris from entering drain system.

Mousetrap drawing by Mark Sujka,
 Design Graphics Specialist,
 WSDOT Design Office.

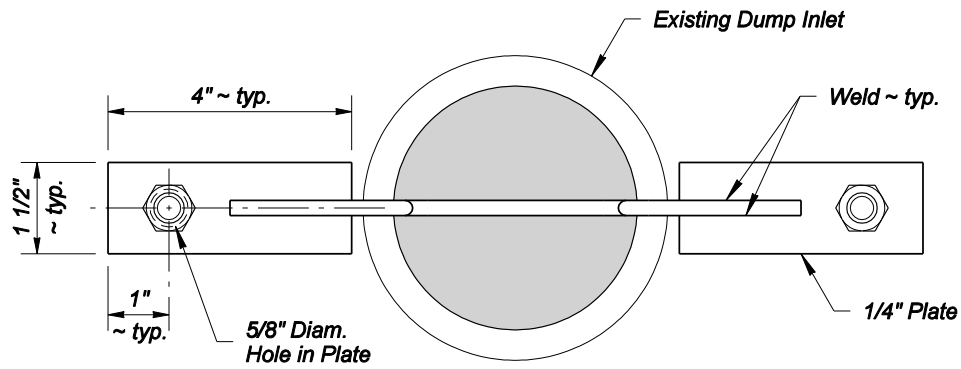
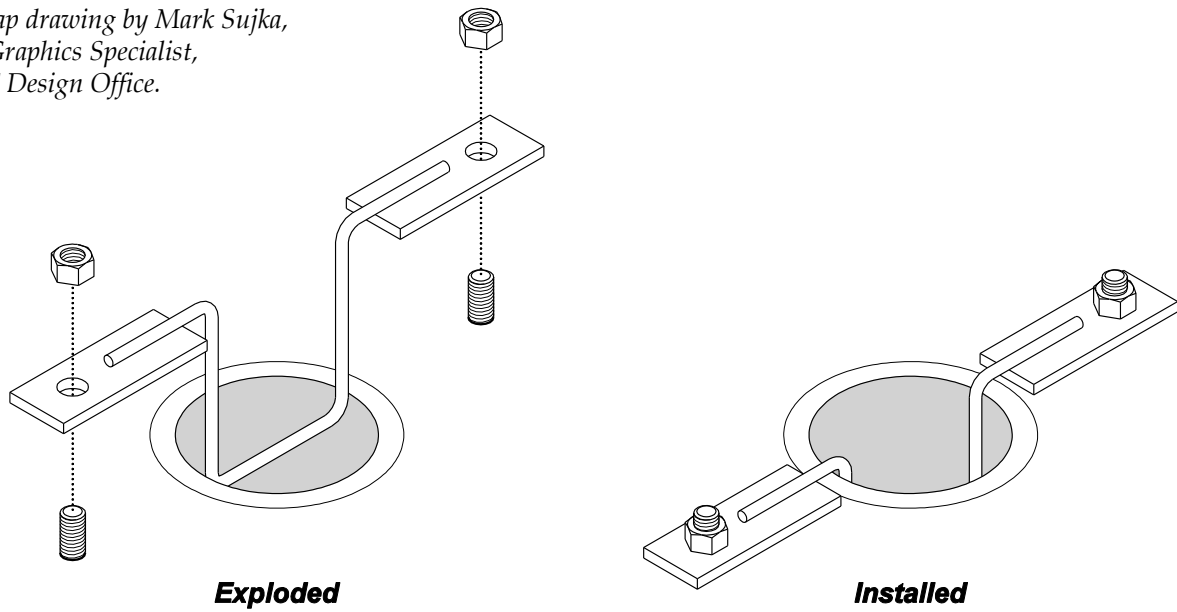

Top View

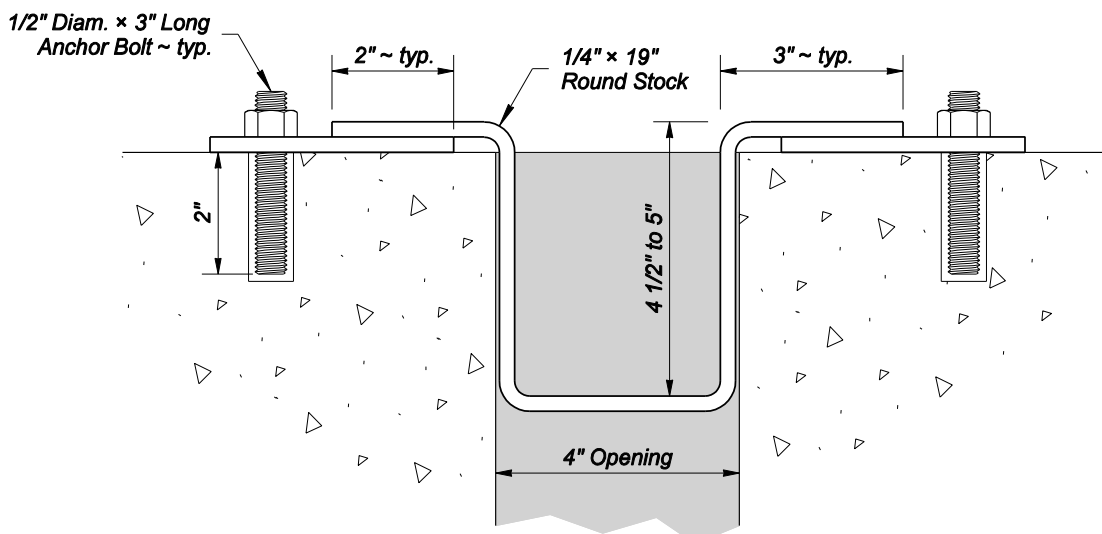

Section View

RV Dump Inlet Restrictor

WSDOT Olympic Region Button Truck

By Roger Chappell, Technology Integration Engineer,
WSDOT Highways & Local Programs WST2 Center

I would like to introduce you to the button truck from the Washington State Department of Transportation (WSDOT) Olympic Region. The WSDOT Olympic Region Raised Pavement Marker Crew is constantly on the road placing and replacing the buttons. The job, if done correctly, is transparent to most of the traveling public, yet it contributes directly to the safety and drivability of the driving experience.

This article is a tour of the custom equipment the crew built to do their job. At the heart of the operation is the button truck. The crew has brought several generations of the button truck to the Pacific Northwest Transportation Technology Expo (PNTTE) in Moses Lake, Washington. The truck described in this article has been built from many years of experience. The crew is always looking for opportunities to improve the way they do business, so I am sure you will continue to see more improvement as time goes on.

The cab of the button truck was chosen for its visibility. When placing buttons, the driver needs to be able to drive very close to the centerline of the road, while watching the button operation and traffic at the same time. On the dashboard of the truck is a DMI (Distance Measuring Instrument), used to find the location for button placement along the highway and to



Entered as part of the Build a Better Mousetrap at the PNTTE Expo.

measure the intervals between buttons. The radios in the cab are used to communicate with the various vehicles and other WSDOT staff during the button operation. Switches have been added in the cab to control the heat of the adhesive tank, hose heater, air compressor, and generator. Having these controls in the cab, as well as in the back of the button truck, allows the operator to pre-start each piece of equipment while driving to the job. The operator can also quickly shut down the equipment if necessary.



The hot seat...where the buttons meet the road.



The seat assembly can be adjusted up or down.



Inside the cab.

The seat assembly in the button truck is approximately 5 feet long (from front to back) and about 3¹/₂ feet wide. The seat assembly can be raised and lowered up to 8 to 10 inches. When traveling to and from the job site, the whole seat assembly can be raised for ground clearance. During operation, the assembly is lowered to approximately 2 inches above the ground for easy installation and removal of buttons.

The adhesive wand can move easily from side to side to optimize adhesive placement and alignment. Hot adhesive is pumped from the tank on the back of the vehicle through heated hoses and is controlled by a foot pedal. Then a button is placed on the hot adhesive. There is a separate compressed air nozzle attached to the wand that can be used to blow off debris and water before adhesive placement. The operator also has compressed air available to operate air impact chisels for button removal.

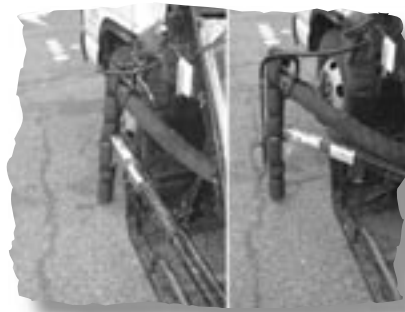

The adhesive wand can be adjusted in or out by the operator to match the alignment.

Once the old buttons are removed, they can easily be tossed into the bin next to the operator. By removing and refilling the bin with empty buckets, the crew can move the dead buttons to another vehicle and empty all the buckets at the end of the day. This bucket rotation allows the crew to keep the operation moving,



Dead button bins.

while only needing to touch a button once. At approximately 132 buttons a mile, the less you have to touch the buttons, the better. The crew carries enough empty buckets to empty the bin three to four times per day.

Behind the dead button bin is the control panel and adhesive tank. The panel controls the hose heat, tank heat and pump, and is connected to the switches in the cab. The tank holds and pumps heated bituminous adhesives, which can be varied depending on the surface conditions.



Control panel and adhesive tank.

The adhesive tank, generator, and air compressor are fueled from one propane tank. The propane tank is located under the air compressor and generator, and a reserve air tank is mounted behind the rear bumper.



Generator, air compressor, and propane tank.



View from rear passenger's side.

This concludes our tour of the WSDOT Olympic Region button truck. For more information about this equipment, contact Robert Ostrom, WSDOT Lead Technician, at (360) 357-2672.



Mousetrap Registration

Name of Invention: _____

Agency: _____ (WSDOT) Region: _____

Mailing Address: _____

City: _____ State _____ Zip+4: _____

Contact Person: _____

E-mail Address: _____

Phone: () _____ Fax: () _____

Inventor(s)/Fabricator(s): _____

E-mail Address: _____

Phone: () _____ Fax: () _____

Supervisor's Name: _____

What prompted this invention (or equipment modification)?

How was it developed?

Labor, Equipment, Materials Used (from scrap pile? Did you purchase any parts?:

Cost Estimate (a rough guess will do):

Benefits to your operations:

Include sketches or plans of your "Better Mousetrap" with dimensions and materials identified, and photographs of the item from all angles (front, top, side, etc.) with the inventors if possible, to:

Build a Better Mousetrap
WSDOT-WST2 Center
PO Box 47390
Olympia, WA 98504-7390

For more information and photos of Mousetraps and Expo, check the Washington State T2 Center's web page:
www.wsdot.wa.gov/TA/T2Center/t2hp.htm
or contact Wendy Schmidt at (360) 705-7386 for details.

You can now register your Mousetrap online at: <http://fmapps.wsdot.wa.gov:590/mousetraps/Register.htm>

Reader Response

Please help the WST2 become more effective by completing this form.

Note: For your convenience, this page is perforated for easy removal from the newsletter.

Name: _____ Title/Org: _____

Mailing Address: _____

City: _____ State _____ Zip+4: _____

E-mail Address: _____

Phone: () _____ Fax: () _____

My idea, comment, suggestion, or local innovation to report on is:

An upcoming workshop/ seminar/ training to include:

Special Interests:

Mail to:

**WSDOT-WST2 Center
PO Box 47390
Olympia, WA 98504-7390**

Or fax to:

(360) 705-6858

State Pavement Technology Consortium

By Keith W. Anderson,
Research Project Manager,
WSDOT Research Office

The State Pavement Technology Consortium (SPTC) is a federal-pool funded project co-led by the Washington State Department of Transportation's (WSDOT) Research Office and Materials Laboratory. It was formed to share information, study issues of common interest, and conduct research on pavements. Minnesota, Texas, and California are also involved in the consortium because of their very strong research programs in pavements.

The consortium has been meeting at least twice each year since 1999. Initial meetings were hosted by each state, usually at their own materials laboratory facility. More recently, the meetings have been held at facilities where the group could learn about other organizations involved in pavement research. This included the Corps of Engineers' Waterways Experiment Station in Vicksburg, Mississippi; the National Center for Asphalt Technology in Auburn, Alabama; and the Western Research Institute in Laramie, Wyoming.

Issues that have been discussed or researched to date include:

- **Cyclic segregation caused by temperature differentials in asphalt pavements.** WSDOT

changed its specifications to include non-random testing when temperature differentials are detected.

- **Dowel bar retrofit corrosion and long-term performance.** WSDOT specifies stainless steel dowel bars for all new construction and all retrofit applications. WSDOT is expecting at least 15 years of additional life from its dowel bar retrofit pavements.
- **Compaction at longitudinal joints.** WSDOT is discussing specification changes with the Washington Asphalt Pavement Association.
- **Development of a database for hot mix asphalt test results.** WSDOT is in the process of integrating pavement management data, construction data, and hot mix testing data into a single web accessible database.
- **Use of hydraulic cements for rapid construction of Portland Cement Concrete Pavement (PCCP).** WSDOT will not use hydraulic cements due to its quick set time that makes it impossible to finish the pavement to an acceptable ride quality.
- **Software to aid in the rapid construction of pavements in high traffic locations.** WSDOT is using the software on several design projects in the WSDOT Northwest Region.

- **Precast prestressed concrete pavements.** WSDOT will not be implementing the use of precast prestressed PCCP due to high construction costs and poor ride issues.
- **Traffic simulation software for construction in high traffic areas.** WSDOT is looking at the implementation of this type of software for future use.
- **Benefits of tack coat for the long-term performance of asphalt pavements.** WSDOT and the SPTC are investigating the feasibility of a research project to sort out the tack coat issue.
- **Pros and cons of tining concrete pavements and bridge decks.** WSDOT is gathering information that will support a request to the Federal Highways Administration for a waiver from the tining requirement.

The WSDOT Materials Laboratory staff has estimated that they have saved in excess of \$67,000,000 as a result of the information derived from their involvement in the consortium. Their investment to date has been \$165,000. The web site for the consortium is located at <http://pavements.ce.washington.edu/sptc/>.



For more information, contact Keith W. Anderson at (360) 709-5405 or anderke@wsdot.wa.gov.

Automated Real-Time Road Weather System (ARROWS)

By Doug Brodin, Research Project Manager,
WSDOT Research Office

For the past five years, a research project for the Washington State Department of Transportation (WSDOT), conducted by the Atmospheric Sciences Department at the University of Washington through the UW Transportation Center (TRAC), has made substantial progress in developing innovative web-based approaches for providing weather and road information to WSDOT personnel and the traveling public. Recently, an operational version of an automated real-time road weather system (ARROWS) was developed and is currently being tested. It is a weather related decision tool to aid WSDOT personnel in predicting road conditions, milepost by milepost, all across the state.

The system goes beyond forecasting weather and uses real-time data to assist in predicting road temperatures. ARROWS provides decision makers with computer generated, high-resolution, 24-hour

forecasts for the entire state highway network. The intent is to assist maintenance staff in assessing where, when, and if pinpointed stretches of highway will experience weather-related problems. It also serves as a one-stop shop for weather information through links to other sources.

During the winter of 2003-04, ARROWS will continue to be refined, and its first winter test will occur. Results of this test will be analyzed and reported. Due to ARROWS being a research effort and having limited server capacity, access to ARROWS is limited to WSDOT personnel.



For more information, contact Ed Boselly, WSDOT Road Weather Program Manager, at (360) 705-7863.

2004 Summer Employment On-line Student Referral Program

Does your agency need extra help in the summer with construction projects, flagging, surveying, inspection, support for engineers and technicians, drafting, traffic counting, office support, inventorying, recordkeeping, and more? Help an engineering student secure employment this summer by letting them know of jobs available in your agency.

The WST2 Center provides an on-line summer employment referral service to benefit local agencies and college students enrolled in civil engineering or other technical fields. Over the years, hundreds of jobs have been posted to this web site for students in colleges and universities from around the state to access. For informational purposes, jobs from 2003 are currently posted at:

<http://www.wsdot.wa.gov/TA/T2Center/StudentReferral/>

If you will have jobs available this summer, fill out the on-line Local Agency Form and mail or fax it to the WST2 Center. If you are a college student, you can expect that jobs will begin to be posted starting in March 2004. You should check back often, as jobs will be posted for several months. If you have questions about this program, contact Laurel Gray at (360) 705-7355 or grayl@wsdot.wa.gov.



Words from the Chair



Volunteer organizations like the Northwest Pavement Management Association (NWPMA) can only be successful if there are individuals willing to give of their time, their energy, and their expertise. This was very evident at our recent, successful Fall Conference held in Portland, Oregon. At the risk of naming some and leaving out others, I would just like to say a big "Thank You" to all the volunteers (organizers and speakers) who contributed to making the conference a worthwhile experience for our attendees.

During the conference, our executive board for the coming year was elected. You can go to our web site and click on "Who's Who at NWPMA." The NWPMA web site can be accessed at <http://www.wsdot.wa.gov/TA/T2Center/Mgt.Systems/PavementTechnology/nwpma.html>.

The theme of this year's fall conference was "Beyond Analysis – Applying Pavement Management Strategies." Pavement management is a

systematic process to maintain and preserve one of the most valuable assets for which local government is responsible: our street and road surfaces. Ultimately, our pavement management activities lead to construction, maintenance, and rehabilitation activities. The intent of the conference was to go beyond the computer-related analysis (which is surely important in pavement management), and look at the subsequent activities related to design and construction of these maintenance and rehabilitation projects. The conference included technical training in Superpave asphalt pavement design and Portland Cement Concrete construction and design. Technical sessions focused on preparing plans and specifications and construction and rehabilitation techniques.

So, what NWPMA activities are on the horizon for 2003-2004? NWPMA will be sponsoring two conferences again in 2004. The Spring Conference is slated for the week of March 15 in Yakima, Washington. If you have not yet received information about the

conference, please go to our web site to download agenda and registration information. Our Fall Conference will be held in Tacoma, Washington, in October. Again, keep your eyes open for additional information as the time approaches.

As many of you know, the Washington State Department of Transportation (WSDOT) is moving to a new hot mix asphalt specification in their 2004 Standard Specifications book. This specification identifies a Superpave based process for mix-design and three levels of evaluation. Local agencies have a transition period to incorporate this specification into their federally funded projects. This change has generated a number of questions and WSDOT is working to get information out to the local agencies. In December, the NWPMA, in partnership with the City of Vancouver and Clark County, sponsored a regional meeting to discuss the change to this specification. The meeting included WSDOT personnel, city and county agency personnel, and industry.

A second item relates to pavement condition reporting by cities. In the 2003 legislative session, SSB 5248, Transportation Efficiencies Bill, passed placing additional reporting requirements upon WSDOT, cities, and counties. The Association of Washington Cities (AWC) will be assisting WSDOT Highways & Local Programs with implementing these new pavement-reporting requirements for cities. For the most part, the new requirements within the bill are not applicable to cities, with the exception of reporting city arterial pavement condition ratings. The exact language of the new requirements for cities is as follows:

{+ NEW SECTION. +} Sec. 305. A new section is added to chapter 46.68 RCW to read as follows: During the 2003-2005 biennium, cities and towns shall provide to the transportation commission, or its successor entity, preservation rating information on at least seventy percent of the total city and town arterial network. Thereafter, the preservation rating information requirement shall increase in five percent increments in subsequent biennia. The rating system used by cities and towns must be based upon the Washington state pavement rating method or an equivalent standard approved by the transportation commission or its successor entity.

The arterial network has been defined as those arterials within the federal functional classification system. These are the only streets that will be required to report the pavement condition. Since only 70 percent of the system needs to be reported for this biennium, only the top 30 cities will be asked for pavement condition data, assuming that this will meet

the 70 percent requirement for reporting. WSDOT's goal is to keep these new reporting requirements as simple as possible for cities to implement, while at the same time showing the Transportation Commission and Legislators that we are managing our street networks in an efficient manner with limited resources.

The NWPMA will be involved in two ways. First, AWC and WSDOT are soliciting volunteers from cities to serve on an ad-hoc committee to address any issues that come up in implementing these new requirements. For example, are we collecting the right data elements to convey meaningful information? How do we want to present the data to the Transportation Commission? NWPMA members are involved in this committee and will work with WSDOT and AWC to provide meaningful data to the Commission.

In addition, an NWPMA technical committee is at work reviewing condition survey analysis techniques used for determining index values used to report pavement condition. This work is ongoing and you can check our web site to monitor progress.

Finally, I feel strongly that this organization can only be successful if it is responsive to its membership and if it provides information and services which the membership finds valuable. I welcome any and all comments. Please e-mail me at bill.whitcomb@ci.vancouver.wa.us.



Bill Whitcomb
Chairman, NWPMA
City of Vancouver, Washington



News from FHWA Washington Division

By Liana Liu, P.E., Traffic/Safety/
Research/T2 Engineer,
FHWA Washington Division

The 2003 MUTCD

FHWA is pleased to announce that the Final Rule for the issuance of the 2003 Edition of the *Manual on Uniform Traffic Control Devices* (MUTCD) was published in the Federal Register on November 20, 2003. The Final Rule describes all the significant changes in the MUTCD from the 2000 edition and the reasons for the changes.

To access the complete text and figures of the new 2003 MUTCD and to link to the Final Rule notice in the Federal Register, please visit the FHWA's MUTCD web site at <http://mutcd.fhwa.dot.gov>.

FHWA's Priority List of Market-Ready Technologies and Innovations

FHWA released a priority list of 29 Market-Ready Technologies and Innovations during the annual business meeting held September 2003 in Minneapolis, Minnesota.

To download the priority list of Market-Ready Technologies and Innovations, please visit the web

site at <http://www.fhwa.dot.gov/resourcecenter/tech3.htm> or contact Pete Markle at (617) 494-3198.

FHWA RD&T's 2004/2005 Performance Plan

FHWA's Office of Research, Development, and Technology (RD&T) is pleased to inform you that a 2004/2005 Performance Plan is posted on the web. The Plan describes the research that we will conduct, and the products and services we will provide in fiscal years 2004 and 2005. It also serves as a guidepost to direct our efforts toward improving operations and enhancing services. You may access both html and Adobe Acrobat versions of the report at <http://www.tfrc.gov/about/03085/index.htm>.

Interactive Highway Safety Design Model (IHSDM) Training Course

FHWA is offering a two-day IHSDM training course. Participants in this training will learn how to use IHSDM software to analyze existing or proposed two-lane rural highway alignments, to interpret IHSDM output to assist in making project design decisions, and to recognize how IHSDM capabilities can be

applied throughout the highway design process.

The course is available to federal, state, and local transportation personnel, as well as consultants involved in the planning and design of rural two-lane highways. For information on scheduling a speaker, please contact Clayton Chen, Office of Safety, at (202) 366-4656 or clayton.chen@fhwa.dot.gov; or Ray Krammes, Office of Safety Research and Development, at (202) 493-3312 or ray.krammes@fhwa.dot.gov. For information on scheduling the NHI course, contact Danielle Mathis-Lee at (703) 235-0528 or danielle.mathis-lee@fhwa.dot.gov.

2003 National Roadway Safety Award

Congratulations! FHWA is very pleased to announce that the City of Bellevue's project, "Bellevue Accident Reduction Program," was selected to receive a 2003 National Roadway Safety Award in the category of Program Planning, Development, and Evaluation. This award was presented to the City of Bellevue in November 2003 during the awards luncheon and press event at the National Press Club in Washington, DC.

New FHWA Office of Safety Geometric Design Program Web Site

A newly developed "Geometric Design" program area (<http://safety.fhwa.dot.gov/geometricdsgn/index.htm>) has been added to the FHWA's Office of Safety web site (<http://safety.fhwa.dot.gov/programs.htm>). At this initial stage, information covered under this Geometric Design program area includes Interactive Highway Safety Design Model (IHSDM), Roadside Safety Analysis Program (RSAP), and Resurfacing Safety Resource Allocation Program (RSRAP). You will find program status, planned activities, technical assistance as well as helpful links to available software, references, reports/documents, workshops, and training opportunities from the above web site.

For more information contact:

Shyuan-Ren (Clayton) Chen,
PhD, PE, PTOE
Federal Highway Administration
Office of Safety Design, HSA-10
400 7th Street SW, Room 3407
Washington, DC 20590

(202) 366-4656 – voice
(202) 366-2249 – fax
clayton.chen@fhwa.dot.gov

Rocky Mountain Maintenance Workshop

By Peter Lyon,
Environmental Specialist,
WSDOT Maintenance Office

You can learn a lot from reports and newsletters, but nothing beats firsthand experience. At least that's the consensus of a group of western state and federal maintenance engineers who recently paid a visit to Washington. On September 9-10, 2003, the Washington State Department of Transportation (WSDOT) hosted the 2003 Rocky Mountain Maintenance Workshop. The purpose of the event, sponsored by the Federal Highway Administration's (FHWA) Border Technology Exchange Program (BTEP), was to bring together experts from across the U.S. and Canada for a firsthand view of WSDOT's maintenance facilities, equipment, and projects.

A total of 30 state and district maintenance engineers representing two Canadian provinces, ten states, and one federal agency participated in the event. Participants were from Washington D.C., North Dakota, South Dakota, Colorado, Wyoming, Alaska, Montana, California, Idaho, Oregon, and British Columbia and Alberta, Canada.

On the first day of the workshop, a chartered bus transported the engineers through parts of the Northwest and North Central Regions along I-90 and US 2.

Along the way, the delegates were treated to presentations from WSDOT employees on the following topics:



Attendees gather around the tank used by WSDOT's Avalanche Control section.

- Urban Maintenance Challenges
- Emergency Preparedness
- Incident Response Team
- Signal Maintenance Management System
- Sand Recycling
- Deicer Storage and Water Conservation
- West Nile Virus
- Avalanche Control



Attendees prepare to tour the Tacoma Narrows Bridge.

- Water Meter Computer System
- Endangered Species

On day two, the engineers viewed parts of South Central and Olympic Regions along US 97, I-90, SR 18, and SR 16. Some of the presentations on day two included the WSDOT/Washington State Patrol Joint Operations Policy Statement (JOPS), Storm Management practices, the Salt Pilot project, and the Tacoma Narrows Bridge project. During the Tacoma Narrows Bridge presentation, the engineers not only toured the site of the new bridge, but they learned about the maintenance challenges that WSDOT has overcome with the existing bridge.

As the visiting engineers were being returned to the airport after the two-day workshop, they were asked what information or technologies they found useful and would be taking back to their organizations. At least one or more persons mentioned each of the presentations as valuable. A participant from Caltrans wrote the following in an e-mail: "Please pass on the message that Caltrans was very impressed with the staff [WSDOT] and their work toward innovation and improvements. I really felt all of the staff presenting had a passion for their work. That is something no class can teach. Thanks again."



Hot Topic – Relationship Between Speed and Crash Risk

By Jennifer Boteler, WSDOT Librarian

In 1987, states were allowed to raise speed limits up to 65 mph on certain Interstate roads, and in 1995, the National Maximum Speed Limit was repealed. Since then, there have been a number of studies and reports on the effects of increased speed limits on accident rates. Judging by the latest transportation literature, this subject is still a hot topic under investigation. The following research has recently been released regarding vehicle speed and road safety.

The effect of increasing rural interstate speed limits in the United States. T.L. Patterson, W.L. Firth, L.J. Povey, and M.D. Keall. *Traffic Injury Prevention* Vol. 3, No. 4, 2002. pp. 316-20

Within a year of the repeal of the National Maximum Speed Limit in the United States, 23 states had raised their rural interstate speed limits to 70 or 75 mph. The effect on rural interstate fatalities between 1992 and 1999 was examined by modeling between the old and the new speed limit. Fatalities within states that raised their speed limits to 75 mph and 70 mph were 38% and 35%, respectively, higher than expected, compared to states that did not change their speed limits. Furthermore, the states that raised their speed limits to 75 mph had a higher rural interstate fatality rate before the speed limit was changed than the other groups of states. (Abstract from TRIS, <http://199.79.179.82/sundev/search.cfm>).

Effect of repeal of the national maximum speed limit law on occurrence of crashes, injury crashes, and fatal crashes on Utah highways. D.D. Vernon,

L.J. Cook, K.J. Peterson, and J. Michael Dean. *Accident Analysis & Prevention*. Vol. 36, Iss. 2, pp. 135-304, March 2004.

Speed limits were increased in Utah and other states after repeal of the national maximum speed limit law (NMSL) in 1995. This study analyzed effects of the increased speed limit on Utah highways on crash rates, including fatality and injury crash rates. Annual (1992–1999) rates for the following highway categories were calculated: urban Interstate segments (current speed limit 60–65 miles per hour (mph)); rural Interstate segments (current speed limit 70–75 mph); 55 mph rural non-Interstate highway segments; and high-speed non-Interstate highways (current speed limit 60–65 mph). Data were analyzed using autoregressive integrative moving average intervention time series analysis techniques. There were significant increases in total crash rates on urban (60–65 mph) Interstate segments (however this was confounded by extensive ongoing highway construction on these highways), and in fatal crash rates on high-speed (60–65 mph) rural non-Interstate segments. The following variables were unaffected: total, fatality, and injury crash rates on rural Interstate segments; fatality and injury crash rates on urban Interstate segments; total and injury crash rates on high-speed non-Interstate segments. These results show an adverse effect on crash occurrence for subsets of crash types and highways, but do not show a major overall effect of NMSL repeal and increased speed limit on crash occurrence on Utah highways. (Abstract from Elsevier ScienceDirect, <http://www.sciencedirect.com>)



Faster Travel and the Price We Pay. Status Report, Vol. 38, No. 10, p. 1, Nov. 22, 2003. Insurance Institute For Highway Safety. <http://www.hwysafety.org/srpdfs/sr3810.pdf>.

For years, Institute [for Highway Safety] and other research has [sic] quantified the price in lives we pay to get from here to there a little bit faster. The most recent estimate is that higher speed limits increase deaths on rural interstates by about 35%. Yet motorists on both rural and urban roads are going faster and faster, encouraged by automakers who build ever more powerful cars and touting their speed capabilities in ad after ad. (From the front cover of Status Report)

The impact of speed on road safety. J. Barker. Transport Research Laboratory (TRL Limited, Crowthorne, Berkshire Co., Eng, UK) Staff Paper PA/SE/3956/03. 3p. 2003.

The latest research pertaining to auto speed and road safety is reviewed. Speeders are defined as drivers who drive above the mean speed of all drivers for a road as well as those who exceed the speed limit or drive at very high absolute speeds. Speeders are more likely to be involved in accidents with the risk rising sharply for driving at high speeds. The speeder profile is likely to be young, male drivers who drive high mileages on business and have a tendency to violate traffic regulations. Cross-sectional and before-after road based studies are described. For each one-mile per hour reduction in mean vehicle speed, accident reductions of between 2% and 9% can be expected. Targeting the problems of the fastest drivers is likely to have the greatest effect in reducing accidents. (Abstract from TRIS <http://199.79.179.82/sundev/search.cfm>)



For help in obtaining full text of any of these publications or for a more comprehensive listing of publications on this topic, contact your local public library or the WSDOT Library at (360) 705-7751 or botelej@wsdot.wa.gov.



If a Picture is Worth a Thousand Words, What is a “Smart Image” Worth?

By Roger Chappell, Technology Integration Engineer, WSDOT Highways & Local Programs WST2 Center

The 2003 Western Washington Road and Street Maintenance Supervisors Conference was a significant event in Ground Based Imaging (GBI) history. Mark Finch, Washington State Department of Transportation (WSDOT) Transportation Data Office (TDO), and Hans Cregg, of Imageware, were at the conference to unveil some of the latest technology to enter the roadway maintenance arena. These two gentlemen are considered leaders in the GBI community.

At the conference, Mark Finch unveiled the latest in 360-degree, on-the-fly imaging with SrView 360. In the Summer 2003 issue of the WST2, Eric Jackson, from WSDOT's TDO, gave us a glimpse of this technology while it was still in the developmental stages. GBI technology, which has proved useful to the planning and engineering groups at WSDOT, is now a useful tool in the maintenance arena and with local agencies. With the use of 360-degree immersive imagery, maintenance managers can quickly view any

road in their jurisdiction from the safety and comfort of their desktops. This technology can be used for locating staging areas for maintenance activities, pre-assessment for overlays, and many other maintenance and asset management functions. Mark Finch, Eric Jackson, and the crew at WSDOT's TDO continue to be on the leading edge of this powerful new technology and have been willing to share their knowledge and skills with others through the Build a Better Mousetrap program and other venues.

For more information about GBI and 360-degree imaging technology, contact Mark Finch, WSDOT TDO Roadway Systems Branch Manager, at finchm@wsdot.wa.gov or (360) 570-2369. You can also visit the WSDOT TDO web site at <http://www.wsdot.wa.gov/mapsdata/tdo/srweb.htm>.

Hans Cregg's presentation at the conference centered on data intelligence and what he calls "smart images." What if you could build intelligence into an image? This would mean that a photo could tell you what it contains, how it relates to other photos in the file, and how it relates to events and

objects in the real world. Let's say you have a box containing a thousand photos. Do you organize them by date, event, or by the type of data they represent? To answer this question, you would need to look at each photo and interpret the events that are captured. For example, your birthday photo is merely thousands of pixels of data, arranged in a pattern, and frozen in time. The camera is a data-capturing device and the photographic paper is a recording medium, like a hard drive. The data surrounding the events in the photo are stored in a separate database called your brain. Without the data in your brain, the images may be worthless.

In the past, I have written several articles about GBI and its impacts to the transportation and public works fields. Typically, GBI systems take an image or series of images of the roadway at a predetermined interval. This allows you to drive along the roadway gathering data from the safety and comfort of your desktop. While these images are very useful, their intelligence has been rather limited. These images "know" where they were taken (road number, milepost, direction of inventory and GPS location),

how they relate to the other images of that roadway, and the date they were taken. What is lacking is an easily searchable description of the data that each image contains. That is where smart images come in. At the Road and Street Maintenance Supervisors Conference, Hans Cregg introduced the concept of smart images. In my opinion, this concept has the potential of revolutionizing the GBI industry. What Hans has done is integrate the power of database intelligence (the brain) with his GBI images. Together, this system combines the intelligence of a database with the data capturing abilities of GBI in one user-friendly interface. Instead of writing on the back of pictures and putting them in boxes, Hans has developed an environment that allows you to do it all with the power of computers and database technology.

By making each image a record in a database, you now have all the search capabilities that a database has to offer. Another advantage is that each record can contain a myriad of other data elements, such as 360-degree hyper linked imagery, spreadsheets, and databases. It is much like writing information on the back of your home photos, except this data is all computerized and searchable. As with most computerized systems, data and data screens can be added to help users extract data from the images. In fact, this may prove to be a preferred method of data collection and interpretation.

Instead of one person's interpretation of images, subject matter experts from a wide variety of disciplines are able to share their interpretations with each other. By using data screens, each group is able to see and identify images that are important to their independent work functions and quickly leverage work done by

other groups as well. For example, a sign maintenance group could develop an on-the-fly inventory of all the signs of a given local agency. Not only could I retrieve a picture of any sign on any road tied to a physical location, I could also have additional information that relates to that particular sign. Information that has traditionally resided in a variety of formats can be brought together in one place and attached to a picture of the actual sign. Information that you cannot see in the picture, such as laser reflectivity readings, installation and replacement schedules, can be added to the image. Asset management and depreciation valuations can also be added. Similar data can be extracted and stored for striping, guardrails, lighting, culverts, and anything else you can see in the image.

Not only do subject matter experts benefit from such a system, but the organization can also benefit. Looking through the eyes of a sign maintenance crew, you'll see signs. Looking through the eyes of an environmentalist, a traffic engineer, and a risk manager will give you perspectives that no one person could have seen alone. The more you look at the images and record the information they contain, the smarter they become. As you add more images over time, you will eventually "cube" the data. Not only will you have years of recorded subject matter experts interpreting the images for you, you will also be able to show the data and image through time, moving both horizontally and vertically through the data structures. For example, I could view an intersection when it was a four-way stop and as turning movements and signalizations were added and modified. Later, I could view the intersection as it became a roundabout and then an

overpass. I could move through time, pausing to read the notes of others who interpreted these same images. I could then use the data for other purposes, such as building predictive models for similar types of intersections in the early stages of development. How do roadway infrastructure, guardrail, and signs perform over time? How do you prove that service to the public increased or decreased with time and budgets? Using smart image technology will give you a visual record to answer these questions.

If you would like to hear more about GBI, make plans to attend the technical session titled "Every Picture Tells a Story" at the APWA Spring Conference, to be held March 23-26, 2004, in Olympia, Washington. For more information about smart image technology, contact Hans Cregg at (360) 264-2271 or roadview@aol.com.

In conclusion, I would like to say that GBI is here to stay. I want to thank Mark Finch and Eric Jackson for their continuing efforts to bring more pixels of data than has ever before been possible with their introduction of SrView 360, and for their continuing improvements to their other imaging products. I would also like to thank Hans Cregg for introducing image intelligence. I believe this technology is the foundation for future data structures and the beginning of knowledge management systems in the transportation field. The first step is to gather the data and the next step is to use it wisely; both steps were well demonstrated at the Road and Street Maintenance Supervisors' Conference. I would like to leave you with the title question: if a picture is worth a thousand words, what is a smart image worth?



WST2 Resources

Free Publications from Your WST2 Center

For Washington residents only due to limited quantities and high mailing costs.

Name	Agency		
Mailing Address	City	State	Zip+4
Phone	Fax	E-mail	

This order form is available on the WSDOT home page at:

<http://www.wsdot.wa.gov/TA/T2Center/T2PUBS.htm>

Fax, e-mail, phone, or mail your order to:

Fax: (360) 705-6858; E-mail: WST2Center@wsdot.wa.gov; Phone: (360) 705-7386; Mail: WST2/WSDOT, H&LP, P.O. Box 47390, Olympia, WA 98504-7390.

- ✓ Check the items you would like to order. An asterisk (*) denotes publications included in the 2003 WST2 CD Library.
- 1999 Audio Visual Catalog, T2 Center
- 2003 WST2 CD Library: Technical Documents
- Asphalt Pavement Repair Manuals of Practice, SHRP, 1993*
- Asset Management Primer, FHWA, 1999
- A Walkable Community is More Than Just Sidewalks, FHWA, 2000
- Building Projects that Build Communities, Community Partnership Forum, 2003
- Concrete PASER Manual, University of Wisconsin, 1998
- Contracting for Professional Services in Washington State, MRSC, 1994
- Crack Seal Application Checklist, FHWA, 2001
- Data Integration Primer, FHWA, 2001
- Designing Sidewalks and Trails for Access, Part 2, FHWA, 2001
- Dust Control on Low Volume Roads, FHWA, 2001
- Dust Palliative Selection and Application Guide, USFS, 1992*
- Entering the Quiet Zone: Noise Compatible Land Use Planning, FHWA, 2002
- Family Emergency Preparedness Plan, American Red Cross, et al., 1999
- Field Guide for Unpaved Rural Roads, Wyoming T2 Center, 1997
- Fish Passage Through Culverts, FHWA, USDA, 1998
- General Field Reference Guide (Pocket Size), 2002
- Geotextile Selection and Installation Manual for Rural Unpaved Roads, FHWA, 1989
- Getting People Walking: Municipal Strategies to Increase Pedestrian Travel, Rhys Roth, Energy Outreach Center
- A Guide for Local Agency Pavement Managers, NWT2 Center, 1994*
- A Guide for Erecting Mailboxes on Highways, AASHTO, 1984
- HMA Pavement Smoothness, FHWA, 2002
- Improving Conditions for Bicycling and Walking, FHWA, 1998
- Improving Highway Safety at Bridges on Local Roads and Streets, FHWA, 1998
- Local Agency Pavement Management Application Guide, WST2 Center, 1997*
- Local Agency Safety Management System, WSDOT, 1998, Reprinted 2000*
- Maintenance of Aggregate and Earth Roads, WST2 Center (1994 reprint)
- Maintenance of Signs & Sign Supports for Local Roads and Streets, FHWA, 2001
- Manual for Controlling and Reducing the Frequency of Pavement Utility Cuts, FHWA, 2002
- Manual of Practice for an Effective Anti-icing Program: A Guide for Highway Winter Maintenance Personnel, FHWA, 1996*
- New Generation of Snow and Ice Control, Anti-icing and RWIS, FHWA
- Pavement Surface Condition Field Rating Manual for Asphalt Pavement, NWPMA, WSDOT, 1999*
- Planning & Implementing Pedestrian Facilities in Suburban and Developing Rural Areas, TRB, 1987
- Recommendations to Reduce Pedestrian Collisions, WSDOT, December 1999
- Redevelopment for Livable Communities, Rhys Roth, Energy Outreach Center, 1995
- Reflective Sheeting Identification Guide, FHWA, 2001
- Roundabouts: An Information Guide, FHWA, 2000
- Scenic Byways Map of Washington State, 2003
- School Administrator's Guide to School Walk Routes and Student Pedestrian Safety, Washington Traffic Safety Commission and WSDOT, 2003
- Signposts for Snow Trails, USDA, 1998
- Soil Bioengineering: An Alternative for Roadside Management, USDA-FS, 2000
- State-of-the-Art Survey of Flexible Pavement Crack Sealing Procedures in the United States, CRREL, 1992
- Streetwise, A Simplified Local Agency Pavement Management System, WSDOT, 2000*
- Superpave System – New Tools for Designing and Building More Durable Asphalt Pavements, FHWA, 1996
- Traffic Calming: A Guide to Street Sharing, Michael J. Wallwork, PE, 1993
- Trail Construction & Maintenance Notebook, USDA Forest Service, 2000
- Utility Cuts in Paved Roads, Field Guide, FHWA, 1997
- W-Beam Guardrail Repair and Maintenance, FHWA, 1996
- Washington Bicycle Map, WSDOT, 2001
- Washington State Highway Map, WSDOT, 2002
- Wetland Trail Design and Construction, USDA, 2001
- Wildlife Habitat Connectivity Across European Highways, FHWA, 2002

Workbooks and Handouts from WST2 Center Workshops

- Access Management, Location and Design, FHWA, (NHI) 2001
- Application of Geographic Information Systems for Transportation, FHWA, 1999
- Construction Documentation: Construction Training Manual for Local Agencies, WSDOT, 2003
- Design, Construction and Maintenance of Highway Safety Features and Appurtenances, FHWA, 1997 (update included)
- Environmental Overview, LAG Manual Chapter 24, WSDOT, 2003
- Handbook for Walkable Communities, by Dan Burden and Michael Wallwork

Videotapes

- Driving Modern Roundabouts, City of Lacey, City of Olympia, and WSDOT, 2002
- Walkable Communities: Designing for Pedestrians, Dan Burden, \$50/set of four videotapes

CD ROM

- Best Practices for Road Weather Management, FHWA, August 2002
- Building Projects that Build Communities, WSDOT, 2003
- Driving Modern Roundabouts, City of Lacey, City of Olympia and WSDOT, 2002
- Gravel Roads: Maintenance and Design Manual, SD LTAP, 2000*
- Pedestrian/Bicycle Crash Analysis Tool, FHWA, 1999
- Pedestrian Facilities Guidebook, WSDOT, 1997
- Technology Transfer CD Library Technical Documents, 5th Edition, Winter 2003-2004
- Tools for Identifying Land Use Areas with Potential for Pedestrian Travel and Prioritizing Investments, UW/WSDOT, 2001

DVD

- Driving Modern Roundabouts, City of Lacey, City of Olympia and WSDOT, 2002

Non-Credit Self-Study Guides

These non-credit WSDOT self-study guides may be obtained from the WST2 Center. An invoice will be sent with the books.

- Basic Surveying, \$20
- Advanced Surveying (metric), \$20
- Contract Plans Reading, \$25
- Technical Mathematics I, \$20
- Technical Mathematics II, \$20
- Basic Metric System, \$20

Computer Programs

The following applications may be downloaded from the Washington State Department of Transportation Materials Laboratory web page at <http://www.wsdot.wa.gov/biz/mats/Apps/EPG.htm>.

Everseries Pavement Analysis Programs contains three independent modules:

1. Evercalc 5.0 – A FWD Pavement Moduli Backcalculation Program
2. Everstress 5.0 – A Layered Elastic Analysis Program
3. Everpave 5.0 – A Flexible Pavement Overlay Design Program

Important: These programs are updated regularly. Please send your e-mail address to sivanen@wsdot.wa.gov to be included in the mailing list for updates.

Falling Weight Deflectometer (FWD) Area Program – This program is useful in calculating Normalized Deflections Area Value and Subgrade Moduli from FWD Data. The program is available for download at <http://www.wsdot.wa.gov/biz/mats/pavement/fwd.htm>.



Online Resources

Bridge

- WSDOT Highways & Local Programs <http://www.wsdot.wa.gov/TA/Operations/BRIDGE/BRIDGEHP.HTM>

Environmental

- *Environmental Procedures Manual* (M31-11) <http://www.wsdot.wa.gov/fasc/EngineeringPublications/Manuals/EPM/EPM.htm>
 - Regional Road Maintenance Endangered Species Act Program Guidelines <http://www.metrokc.gov/roadcon/bmp/pdfguide.htm>
 - National Marine Fisheries Service Species Listings & Info <http://www.nwr.noaa.gov/>
 - U.S. Fish and Wildlife Service Species Listings & Info <http://endangered.fws.gov/>
 - Washington State DNR's Natural Heritage Program Home Page <http://www.wa.gov/dnr/htdocs/fr/nhp/refdesk/fsrefix.htm>
 - FHWA's Environmental Home Page <http://www.fhwa.dot.gov/environment/index.htm>
- ### Highways & Local Programs List Serves
- Local Agency Guidelines (LAG) Manual <http://lists.wsdot.wa.gov/guest/RemoteListSummary/LAG>
 - Traffic and Safety Management http://www.t2sms-1@lists.wsdot.wa.gov/guest/RemoteListSummary/T2SMS_L
 - Pavement Management http://lists.wsdot.wa.gov/guest/RemoteListSummary/T2PAVE_L
 - WST2 Newsletter http://lists.wsdot.wa.gov/guest/RemoteListSummary/T2News_L
 - WST2 Training http://lists.wsdot.wa.gov/guest/RemoteListSummary/T2TRNG_L

Infrastructure Management & GIS/GPS

The site below has been established to promote interagency data exchange and resources sharing between local governmental agencies.

<http://www.wsdot.wa.gov/TA/T2Center/Mgt.Systems/InfrastructureTechnology/Infathp.html>

Legal Search

- Search RCWs and WACs
<http://search.leg.wa.gov/pub/textsearch/default.asp>
- City Streets as part of State Highways
<http://www.wsdot.wa.gov/TA/Operations/LAG/CityStreets.html>

Local Agency Guidelines (LAG) Manual

<http://www.wsdot.wa.gov/TA/Operations/LAG/LAGHP.htm>

Pavement Management

- Pavement Publications & NWPMA Links
<http://www.wsdot.wa.gov/TA/T2Center/Mgt.Systems/PavementTechnology>
- NWPMA - North West Pavement Management Association
<http://www.wsdot.wa.gov/TA/T2Center/Mgt.Systems/PavementTechnology/nwpma.html>
- Asphalt Institute
<http://www.asphaltinstitute.org/>
- National Asphalt Pavement Association
<http://www.hotmix.org/>
- Pavement (A Web Site for Managing Pavements)
<http://www.mincad.com.au/pavenet>
- SuperPave Information
<http://www.utexas.edu/research/superpave>

Project Development

- Federal Aid Progress Billing Form
<http://www.wsdot.wa.gov/TA/ProgMgt/Projectinfo/BILLFORM.XLS>
- State Funded Progress Billing Form
<http://www.wsdot.wa.gov/TA/ProgMgt/Projectinfo/BILLFORMSTATE.xls>
- STIP (State Transportation Improvement Program)
<http://www.wsdot.wa.gov/TA/ProgMgt/STIP/STIPHP.htm>

- TIP (Local Agency 6-Year Transportation Improvement Program)
<http://www.wsdot.wa.gov/TA/ProgMgt/STIP/TIP.html>

Research

- WSDOT Research Office
<http://www.wsdot.wa.gov/ppsc/research>
- Looking for a Transportation Research Publication?
<http://www.nas.edu/trb/index.html>
- Municipal Research and Services Center of Washington
<http://www.mrsc.org>

Traffic & Safety

- Safety Management Publications & Information
<http://www.wsdot.wa.gov/TA/T2Center/Mgt.Systems/SafetyTechnology/>
- WSDOT Traffic Data Office
<http://www.wsdot.wa.gov/mapsdata/tdo/>
- Washington State Patrol
<http://www.wa.gov/wsp/wsphome.htm>
- Washington Traffic Safety Commission
<http://www.wa.gov/wtsc>
- National Highway Traffic Safety Administration
<http://www.nhtsa.dot.gov>
- American Traffic Safety Services Association
<http://www.atssa.com>
- Municipal Research and Services Center of Washington
<http://www.mrsc.org>
- Transportation Research Board
<http://www.nas.edu/trb/index.html>

Training

- WST2 Classes & LAG Training
<http://www.wsdot.wa.gov/TA/T2Center/Training/>
- WST2 Class Registration
<http://www.wsdot.wa.gov/TA/T2Center/t2hp.html>
- County Road Administration Board
<http://www.crab.wa.gov/>
- American Public Works Association
<http://www.apwa.net/education>
- Transportation Partnership in Engineering Education Development (TRANSPED)
<http://www.engr.washington.edu/epp>

WSDOT Local Programs Engineers

- Eastern Region (Spokane)
Keith Martin (509) 324-6080,
martink@wsdot.wa.gov
- Northwest Region (Seattle)
Terry Paananen (206) 440-4734,
paanant@wsdot.wa.gov
- Olympic Region (Olympia)
Neal Campbell (360) 357-2666,
campben@wsdot.wa.gov
- North Central Region (Wenatchee)
Paul Maher (509) 667-3090 or 667-2900,
maherp@wsdot.wa.gov
- South Central Region (Yakima)
Roger Arms (509) 577-1780,
armsr@wsdot.wa.gov
- Southwest Region (Vancouver)
Bill Pierce (360) 905-2215,
pierceb@wsdot.wa.gov

Other Online Resources

- Bicycle maps and other information
<http://www.wsdot.wa.gov/TA/PAandI/PAIHP.html>
- Pedestrian information
<http://www.wsdot.wa.gov/TA/PAandI/PAIHP.html>
- Rural Partnerships and scenic byways information
<http://www.wsdot.wa.gov/TA/PAandI/PAIHP.html>
- Better Mousetraps
<http://www.wsdot.wa.gov/ta/T2Center/Mousetraps/>
- Retired Professional Program
<http://www.wsdot.wa.gov/TA/T2Center/Retired.htm>
- Student Referral Program
<http://www.wsdot.wa.gov/TA/T2Center/StudentReferral/>
- LTAP (Local Technical Assistance Program) Clearing House
<http://www.ltapt2.org>
- Institute of Transportation Engineers
<http://www.ite.org>
- Washington State Counties
<http://access.wa.gov/government/awco.asp>
- Washington State Cities and Towns
<http://access.wa.gov/government/awcity.asp>
- Governor's Office of Indian Affairs
<http://www.wa.gov/goia/index.html>
- Southwest Interagency Coop - Grounds Equipment Maintenance (GEM)
<http://www.gematwork.org>

Training Opportunities



Laurel Gray, WST2
Training Program
Coordinator

Washington State T2 Center

Contact: Laurel Gray (360) 705-7355
Wendy Schmidt (360) 705-7386
<http://www.wsdot.wa.gov/TA/T2Center/Training>

To register for a class in this section, use the contact listed above.

The class fees shown apply to both public and private sector students. Classes marked with an asterisk (*) qualify under the Road and Street Management Training Program as a requirement or an elective and contribute to a Certificate of Achievement (CA) in Road and Street Management.

Implementing Superpave in Local Agencies*

March 9, Marysville; March 10, Kent; March 30, Lacey; April 27, Spokane; April 28, Moses Lake; April 29, Yakima. Free. Instruction by the WSDOT Construction Office, Materials Lab, and FHWA. This training will offer local agencies an overview of the Superpave process, highlight changes to the 2004 Standard Specifications, address materials and testing issues, and design and construction considerations from a local agency perspective. These classes should help answer many of the questions and concerns on the part of local agencies regarding the Superpave transition. Another six sessions will be offered in 2005.

Introduction to the Design and Operation of Roundabouts

March 10, Lacey; March 16, Port Orchard. Free. In this course, attendees will gain an understanding of circular intersections and understand the difference between a modern U.S. roundabout and the traffic circle and rotary intersection. Attendees will be aware of software products that can be used to do an acceptable capacity analysis and understand how to compare signalized intersections with roundabouts to determine levels of service. Intersection issues such as sight distance, drainage, pedestrians, bicycles, illumination,

truck-turning templates, and landscaping will be discussed. Signing and striping is essential to a safely operating intersection, and the purpose for each element will be covered as it relates to the law. Attendees will also see a wide variety of operating roundabouts in Washington State and from around the country.

Construction Documentation (LAG Program)

March 16, Port Orchard; March 17, Lacey; April 13, Kent; April 14, Mount Vernon. Free. Instructor: Ken Hash, WSDOT SW Region. Regional Local Program Engineers will be in attendance to answer questions. This course covers three phases: pre-contract, contract, and post-contract documentation of public works projects with FHWA funding. Local agency and contractor's documentation is discussed, with a strong emphasis on the documentation requirements of the field inspector. On completion of this course, participants will have a working knowledge of: (1) required documentation that will be submitted by the contractor, (2) required documentation for acceptance of contract materials, (3) daily inspector's documentation of the contract work, and (4) source documentation for the monthly progress payment to the contractor.

Bridge Condition Inspection Training (BCIT)

March 15-26, Lacey. Free to Washington State local agencies and consultants; \$700 to out-of-state attendees. Instructor: Grant Griffin, WSDOT Bridge Engineer. This two-week course is based on the "Bridge Inspector's Reference Manual" and will provide extensive training on the condition inspection of in-service bridges. Satisfactory completion of this course will fulfill the training requirements of the National Bridge Inspection Standards (NBIS) for "a comprehensive training course" based on the manual. The training course will cover: bridge inspection programs, review of basic concepts, safety, inspection documentation, reporting NBIS inventory items, and bridge management systems. The course is for new bridge inspectors or those desiring a refresher. Attendees should have general understanding of bridges.

Geosynthetics Engineering Workshop*

March 30-April 1, Shoreline. \$400. 1.8 CEUs. Instructors: R. D. Holtz and Barry Christopher, University of Washington. This National Highway Institute class is a three-day design and construction course. The course will provide training on the correct, cost-effective utilization of geosynthetics in transportation applications. State-of-the-practice utilization of geosynthetics in highway works and developments are reviewed. The use of geotextiles, geogrids, pavement edge drains, drainage composites, erosion control materials, sediment control materials,

and geomembranes are examined. Applications of filtration, drainage, temporary and permanent erosion control, sediment control, roadway separation, roadway reinforcement, roadway subgrade improvement, pavement overlays, embankments over soft foundations, mechanically stabilized earth walls, mechanically stabilized earth slopes, geomembrane containment ponds, and geomembrane pavement encapsulation are covered. The course is for federal, state, and local transportation personnel and private sector construction engineers and project inspectors involved with design and/or construction of transportation facilities that incorporate earthwork.

Writing Skills*

April 7-8, Tacoma. \$110. Instructor: Jordan Peabody. A two-day workshop designed to reduce the confusion caused by the poorly written word. Anyone who must write on the job, but is not a writing pro, will find the training both pleasant and helpful. Writing techniques apply to letters, manuals, speeches, memos, newsletters, e-mail, proposals, reports, bulletins, and minutes.

Roadway Drainage*

April 27, Spokane; May 4, Ellensburg; May 6, Marysville; May 12, Tacoma. \$45. Instructor: Bill Heiden. This course will discuss basic road design characteristics as it relates to drainage, soil characteristics, basic hydrology (drainage areas, runoff factors, rainfall intensity), hydraulics (culvert materials, sizing culvert, sizing ditches), placement of culverts, culvert end treatments and culvert and ditch maintenance. The course is intended to cover the needs of all people responsible for roads, from managers to operators. The course will not provide design criteria for engineers.

Basics of a Good Gravel Road*

April 29, Yakima; May 11, Tacoma. \$45. Instructor: Bill Heiden. This is a basic road maintenance class. All major problems of unpaved gravel roads will be addressed: washboarding (corrugation), traffic patterns, rutting, surface drainage, dust control, surface material, and roadside obstruction. The techniques that Mr. Heiden teaches can help to reduce unpaved road maintenance expenditures by up to 40 percent of current expenditures in three to five years.

Pavement Condition Rating*

May 4-5, east side; June 1-2, west side; September 7-8, west side. Free. Instructor: Bob Brooks, WST2 Pavement Technology Engineer. Participants will learn to rate any of the pavements commonly found in Washington. The rating values obtained using the definitions and methods learned in this course should compare favorably with those obtained and used in the Washington State Pavement Management System. Each participant should be able to perform a pavement condition survey with reasonable objectivity.

Cultural Resources Training

May 4-7 and October 5-8, The Dalles, OR. \$350. Cultural Resources training takes place twice a year in the spring and fall. This training will introduce participants to the value and significance of Washington's irreplaceable cultural resources. This class provides an exceptional opportunity for local agencies to work with the northwest's most qualified instructors, visiting some of the area's finest examples of cultural resources, and attending the only state-wide training session of this caliber. There will be presentations by Native Americans on their cultural perspective; speakers on state archaeology, prehistory of Washington, and Native American ethnobotany; prehistoric stone artifacts; rare plants; logging in the northwest; and federal and state cultural resource regulations and how they apply to your agency. There will be in-field lessons on learning how to "read" the landscape and recognize probable cultural resources located at the site, and sharing preservation techniques and strategies. This training is for any individual who wants to become knowledgeable about cultural resources and possess the necessary skills to address basic resource management problems associated with cultural resources. Call the WST2 Center at (360) 705-7386 to have your name placed on a wait list; these two classes are not available for on-line registration.

Introduction to GPS Mapping Grade Equipment

\$325. This is a three-day class. Sessions can be scheduled upon request or scheduled for an individual agency. Fee is based on four students per session. Instructor: Max Schade. This is an introductory course on mapping grade GPS equipment and is taught by a Trimble-certified instructor. It is designed to provide basic knowledge and skills in the use of GPS technology in mission planning, data gathering, and data processing. The training will enable field operations personnel to use new methods and Trimble mapping grade equipment as well as understand problems encountered when using the GPS satellite constellation.

Coming in 2004

- Purchasing, Bidding and Contract Management – four sessions.
- Contract Specification Writing – several sessions.
- Environment Overview Workshop – six to eight sessions statewide.
- Making Effective Presentations – one session, west side.
- Introduction to Pavement Management Systems – one session, west side.
- Pavement Design – one session, west side.

Local Agency Guidelines (LAG) Training

Unless otherwise stated, the courses in the LAG program are free.

- **Appraisal Review Workshop:** *LAG Manual* Chapter 25. \$100. Four sessions were recently held. One more session may be added in the spring.
- **Construction Documentation:** *LAG Manual* Chapters 51, 52, and 53. For class schedule, see page 32.
- **Consultants:** *LAG Manual* Chapter 31. Training is now offered by the University of Washington under the title "Managing Consultants." See the TRANSPEED section on page 36 for class details.
- **Contract Specification Writing:** *LAG Manual* Chapters 42-46. \$50. Three to four sessions to be scheduled in 2004.
- **DBE/EEO/OJT:** *LAG Manual* Chapters 26 and 27. This class will provide local agencies with a basic understanding of the rules and procedures on Disadvantaged Business Enterprise (DBE), Equal Employment Opportunity (EEO), and On-the-Job Training (OJT) for federally funded projects. There are no sessions scheduled at this time.
- **Emergency Relief Programs:** *LAG Manual* Chapter 33. Curriculum will soon be available on CD. The course covers instructions on procedures applicable to emergency projects funded by the Emergency Relief Program on federal-aid highways and by the Federal Emergency Management Agency disaster assistance for projects not on federal-aid highways.
- **Enhancement Program:** *LAG Manual* Chapter 62. Training for this course will become available after the new Federal Act is in place.
- **Environmental Overview for Local Agencies:** *LAG Manual* Chapter 24. Classes will be scheduled for fall 2004. This course is also an elective in the Road and Street Management Program.
- **Right of Way Procedures Workshop:** *LAG Manual* Chapter 25 and the Federal Perspective. There are no sessions scheduled at this time.
- **Right of Way Plans Preparation:** *LAG Manual* Chapter 25. This is a four-hour class. \$50. There are no sessions scheduled at this time.

- **LAG Manual Overview:** This course will give a basic overview of the *Local Agency Guidelines Manual* and the latest revisions. There are no sessions scheduled at this time.

It is important that you let us know if you have an interest in any of the courses listed above by logging on to our web site at <http://www.wsdot.wa.gov/TA/T2Center/T2hp.htm> and accessing the online request list. Click on "WST2 On-Line Request," fill out the form, and send. Individual classes will be developed in response to the request lists. If your name is on the list, you will be notified by e-mail when classes are scheduled.

If you have questions about the LAG Program, contact Larry Schofield at (360) 705-7380 or schofil@wsdot.wa.gov.

The Endangered Species Act Training Program Now Approved by US NMFS

Over three years of dedicated effort of the U.S. National Marine Fisheries Service (NMFS) and the Puget Sound Regional Forum culminated on August 15, 2003, when the Regional Road Maintenance ESA Program was approved by NMFS. The program was approved on the condition that *ALL* program elements are implemented by agencies seeking approval for routine road maintenance activities. An important program element is the Regional Road Maintenance training program that was launched in spring 2002. Since then, about 1,200 maintenance supervisors, engineers, environmental staff, crew leads, and maintenance crew members have been trained. The initial series of classes were scheduled primarily for agencies that had committed to the Regional Road Maintenance Program (RRMP) Guidelines and had submitted a "Part 3 Application." The training is now available for anyone requesting it. The goal of the program remains to serve all maintenance personnel who want to expand their roadway maintenance knowledge and skills, and in particular, learn more about Best Management Practices (BMPs) in roadway maintenance.

The Part 3 Application is an agency commitment to the ten program elements (of which the training program is Element #3), and can be obtained from the following web site: <http://www.metrokc.gov/roadcon/bmp/pdfguide.htm> or by contacting Janine Johanson at METRO KC, (206) 205-7101. The ultimate goal is to have all agency roadway maintenance personnel trained with approved Part 3 Applications on file.

The University of Washington's Transportation Professional Development Program (TRANSPEED) is coordinating and presenting the training program. The training tracks are described below. Fees for each track are part of a legislatively approved agreement for the 2003-05 biennium. The agreement provides partial funding to help maintain the low tuition rates. For program information or course registration, please contact Julie Smith at (206) 543-5539 or jsmith@enr.washington.edu. Program and registration information can also be found at <http://www.enr.washington.edu/epp/esa/reginfo>.

Four ESA Training Tracks

The ESA Training Plan has four separate tracks:

- **Track 1: Briefing for Regional Decision Makers**
2 hours. No fee. This track is an overview of the ESA program for regional level management and administration. It is a stand-alone training class and not part of the required training program. It is offered by members of the Regional Road Maintenance Forum. Call Roy Harris or Gerry Crum at (425) 257-8800 for information. Information may also be obtained from Janine Johanson, METRO KC, at (206) 205-7101.
- **Track 2: Introduction, Design and BMPs: Monitoring and Environmental Roles for Technical and Scientific Staff**
1.4 CEUs. Tuition is \$235. This two-day course is an overview of the procedures for technical, professional and environmental staff, supervisors, and leads involved in maintenance activities. This track provides an introduction to the program Guidelines, design, habitat, the ten program elements, and maintenance BMPs to meet ESA requirements.
- **Track 3A: Classroom Introduction to ESA and Outcome-based Road Maintenance for Field Crews**
0.7 CEUs. Tuition is \$160. This one-day course is an overview of the procedures for field crews and leads involved in maintenance activities. This track provides an introduction to the program Guidelines, design, habitat, environmental roles, the ten program elements, and implementation of maintenance BMPs to meet ESA requirements.
- **Track 3B: Road Maintenance Crew Training in the Field Environment: Applying Maintenance BMPs**
0.7 CEUs. Tuition is \$190. This one-day course is conducted in a field setting where teams of maintenance crews construct, test, and assess the effectiveness of a variety of BMPs. Participants will also learn how to monitor each BMP and measure its

outcome in comparison to the outcome goals established in the approved program. *Note:* Track 3A is a prerequisite for Track 3B.

- **Track 4: Train the Trainer for the Regional Road Maintenance Program**

1.4 CEUs. Tuition is \$240. For agency-selected ESA trainers. This two-day course focuses on training skills and techniques, and evaluates, prepares, and certifies candidates to teach the Regional Road Maintenance Program classroom training (Tracks 2 and 3A) and field demonstrations of BMP installations.

Modified Tuition Rates

Tuition rates for this program have been revised and include two major differences from the previous program rates. First, costs for classroom facilities and other logistical costs that were previously provided by the sponsoring agency are now being offset by the funds provided through a support agreement with WSDOT. Secondly, agencies can now lower the training costs for its participants by providing a classroom facility/field site and equipment, and covering costs for instructional handouts for a full class. Those interested in exploring this option should contact Julie Smith at (206) 543-5539 or jsmith@enr.washington.edu. She and the Program Director, Jim McManus, will calculate and forward modified tuition rates.

Looking to the Future

During the past year, the Regional Road Maintenance training program has been focused on the ESA issues related to fish species in the Puget Sound Region. The training has also been conducted in other locations, such as Jefferson County. In addition, the University of Washington has been asked to furnish instructional assistance by teaming with new Track 4-trained instructors who are beginning to train within their agencies. This instructional support has been quite successful and is expected to be an ongoing asset to agencies seeking supplemental and/or updated program information after their initial training has been completed.

The training program may also have far wider applications and venues. These procedures were developed to provide a comprehensive outline of effective management practices applicable in any area or maintenance setting. The training is thus appropriate for all roadway agencies that seek to implement a consistent roadway maintenance program that is environmentally and ecologically sound and provides a solid structure for good roadway maintenance practices.

TRANSPEED University of Washington

Contact: Christy Roop Pack
(206) 543-5539, toll free 1-866-791-1275
fax (206) 543-2352
<http://www.engr.washington.edu/epp>

To register for a class in this section, use the contact listed above.

The prices in this section are for local agency / non-local agency.

Urban Street Design

March 1-3, Seattle. \$320 / \$520.

Determining Contract Working Days

March 9, Seattle; May 11, Lacey. \$275 / \$375.

Fundamentals of Traffic Engineering

March 17-19, Seattle. \$355 / \$555.

Work Zone Traffic Control Plan (TCP) Design

March 23-25, Lacey; June 14-16, Spokane. \$370 / \$570.

Managing Scope, Schedule and Budget

March 31-April 2, Seattle. \$685 / \$885.

Legal Liability for Transportation Professionals

April 5-6, Wenatchee; April 8-9, Seattle. \$270 / \$450.

Manual on Uniform Traffic Control Devices (MUTCD)

April 14-16, Seattle. \$320 / \$520.

Stormwater Engineering

April 20-22, Seattle. \$320 / \$520.

Technical Communication for Transportation Professionals

April 27-28, Seattle. \$300 / \$500.

Traffic Calming Techniques and Management

May 3-5, Seattle. \$370 / \$570.

Managing Consultants

May 11, Lacey (web-based begins April 20). \$485 / \$650.

Traffic Signal Design

May 26-28, Lacey. \$400 / \$585.

Traffic Engineering Operations

June 9-11, Lacey. \$320 / \$520.

Engineering Professional Programs (EPP) University of Washington

Contact: Emily West
(206) 543-5539, fax (206) 543-2352
<http://www.engr.washington.edu/epp>

To register for a class in this section, use the contact listed above.

Cold Regions Engineering Short Course

August 5-9, Seattle; October 28-November 1, Seattle.
\$1,295 early registration, \$1,355 late registration.

Fleet and Shop Management Workshops

One workshop: \$325
Two workshops: \$599

■ **Fleet Shop and Facility Management**
March 25, Seattle. 8:00 am to 5:00 pm

■ **Air Bag Systems**
March 25, Seattle. 8:00 am to 5:00 pm

■ **Vehicle Fleet Management**
March, date to be announced, Seattle.

Professional Engineering Practice Liaison (PEPL) University of Washington

Contact Stephanie Storm
(206) 543-5539, fax (206) 543-2352
<http://www.engr.washington.edu/~uw-epp/>

To register for a class in this section, use the contact listed above.

Fish Passage Considerations in the Design and Retrofit of Culverts

March 9-10, Seattle. \$495 before February 24, \$530 thereafter.

Achieving Real Success as a Project Manager

March 23-24, Seattle. \$475 before March 9, \$510 thereafter.

Construction Site Erosion and Pollution Control

April 13-14, Seattle. \$475 before March 30, \$510 thereafter.

Project Leadership Workshop

May 12-13, Seattle. \$655 before April 28, \$685 thereafter.

Geology and Geomorphology of Stream Channels

May 18-19, Seattle. \$495 before May 4, \$530 thereafter.

Associated General Contractors (AGC)

Contact Beth Sachse
(206) 284-4500, fax (206) 284-4595
bsachse@agcwa.com
<http://www.constructionfoundation.org>

To register for a class in this section, use the contact listed above.

Construction Site Erosion and Sediment Control Certification

These WSDOT approved classes are presented by the AGC Education Foundation and available on the following dates:

March 10-11, Everett/Shoreline; March 31-April 1, Seattle; April 21-22, Tacoma; May 12-13, Seattle; June 2-3, Tacoma; June 23-24, Seattle.

- Recertification requires attendance on Day 1 only, successfully completing exam, and proof of previous WSDOT certification. Cost: \$200
- Certification training lasts a day and a half and requires successfully completing end of course exam. Cost: \$275

AASHTO Roadside Design Guide, Web Based Training

NHI Course Number: 380032C

This web-based course is approximately 14 hours long and is available anytime – 24 hours, 365 days a year via the Internet. The cost for non-FHWA employees is \$230 per participant and includes a copy of the 2002 AASHTO "Roadside Design Guide." This course provides an overview of the 2002 AASHTO "Roadside Design Guide." Emphasis is on current highway agency policies and practices. Participants must register online at <http://www.nhi.fhwa.dot.gov/registerdl.asp>

Computer Requirements: You will need a fairly recent version of a browser (such as Internet Explorer 4 or 5 or Netscape 4 with JavaScript enabled), the latest version of Macromedia Shockwave and Flash (which you can download from the Internet), and a connection to the Internet (at least 56K modem). An older computer such as a Pentium 100 would work, but it would be slower than a Pentium III. For more information, visit <http://www.nhi.fhwa.dot.gov>

Road Builder's Clinic

March 2-4, 2004, Coeur d'Alene, Idaho.
For information, contact WSU Conferences and Professional Programs at 1-800-942-4978.

Northwest Pavement Management Association Conference

Spring Conference scheduled for the week of March 15, 2004.
Contact Bob Brooks at (360) 705-7352 or brookbo@wsdot.wa.gov.

Vehicle Maintenance Management Conference

March 22-25, 2004, Seattle, Wash.
Contact UW Engineering Professional Programs at (206) 543-5539 for more information.

APWA 2004 Conferences

Spring: March 23-26, 2004, Olympia, Wash.

Contact Jay Burney at (360) 753-8740 or jburney@ci.olympia.wa.us.

Fall: October 19-22, 2004, Kennewick, Wash.

Contact Bill Goodwin at (423) 741-5026 or bgoodwin@reidmidd.com.

Supervisors' Conference

April 20-21, Best Western Conference Center, Fife, Wash. A small fee will apply.
This is a one-day conference held on two days; choose the day you want to attend. Contact the WST2 Center at (360) 705-7355 or grayl@wsdot.wa.gov.

Pacific Northwest Transportation Technology Expo

May 18-19, 2004, Grant County Fairgrounds, Moses Lake, Wash.
Contact WST2 Center at (360) 705-7386.

Pacific Northwest Snowfighters

June 9-17, 2004, Ag Trade Center, Spokane, Wash.
Sponsored by Washington State University.
Contact information available at 1-800-942-4978.

Tips on Team Motivation

Following are edited suggestions on how to motivate your employees that were provided at the "Motivating Your Team" workshop conducted as part of the Washington State Quality 2000 Conference.

Acknowledgement

- Saying, "thank you."
- Give praise.
- Write a quick personal note.
- A little chocolate and caffeine goes a long way.
- Have a great celebration.
- Appreciate publicly.
- Recognize efforts immediately.
- Give a free T-shirt.
- Have a picnic.
- Consistent feedback.
- Make appreciation personal and meaningful.
- Post recognition letters on the bulletin board.
- Give recognition to others that you would like to receive yourself.
- Celebrate anniversaries within the agency.
- Provide acknowledgement in your newsletter.
- Give a friendly "good morning."
- Give support and backing to your employees.

Staff Inclusion

- Develop, with your employees, a vision statement or theme that shows how your employees' work makes a difference. Publish the vision in your workplace.
- Have monthly "all-staff" meetings.
- Share information.
- Let employees see results.
- Ask for employee input.
- When you do meet with staff, be "present."
- Spend one-on-one time with employees.
- Give employees time to share concerns and rejoice.



Communicate

- Clarify expectations.
- Give open, honest communication.
- Listen.
- Give employee your full attention.
- Respond to questions promptly.
- Work in teams.

Find Out What Motivates Your Staff

- Match talents with jobs of the team.
- Discuss their careers with them.
- Be sincere about employee's well being.
- Make motivation personal.
- Look for opportunities to establish rapport.
- Walk around and get to know your employees.
- Trust what employees tell you about their needs.

Empowerment

- Let assistants manage something.
- Provide independence.
- Give employees tools to do their job and then give feedback.
- Provide a flexible, positive, work environment.
- Trust your employees.
- Allow employees to build quality into their work.
- Provide training.

Start With Yourself

- You may need to get out of your comfort zone.
- Show your own enthusiasm and motivation for being there.
- Love the work you do.
- Believe in yourself and know that you have a purpose.

Trust

- Treat each employee fairly and equally.
- Respect and trust.

Fun

- Provide opportunities for laughter.



If this sign needs to be posted, maybe water on the roadway isn't your biggest problem!

This photo was found on the Internet at:
<http://www.geocities.com/ndbratney/signs/sign5.jpg>



Sign of the Times

Do you have a humorous traffic sign to share? Send us a print or e-mail a digital image (preferably a 300 dpi, 1000x1500 dpi jpeg or tif) and we will add it to our collection for publishing. Please provide your name, title, agency or company, and a short description of where and when you saw the sign. We want to give you credit for your participation.

You can e-mail the image to schofil@wsdot.wa.gov

Or mail the photo to:
"Sign of the Times"

WST2 Center
PO Box 47390
Olympia, WA 98504-7390

Please don't send your original photo. Although we will do our best to return the photo, we can't guarantee it.

Washington State Technology Transfer

Washington State T2 Staff

Brian Walsh, P.E.

Technology Services Manager
walshb@wsdot.wa.gov
(360) 705-7387

Larry Schofield, P.E.

Technology Transfer Engineer
schofil@wsdot.wa.gov
(360) 705-7390

Roger Chappell

Technology Integration Engineer
chapper@wsdot.wa.gov
(360) 705-7539

Laurel Gray

Training Program Coordinator
grayl@wsdot.wa.gov
(360) 705-7355

Bob Brooks

Pavement Technology Engineer
brookbo@wsdot.wa.gov
(360) 705-7352

Wendy Schmidt

Training Operations Coordinator
schmidw@wsdot.wa.gov
(360) 705-7386

Washington State T2 Advisory Committee

Bud Cave

Deputy Operations Manager
Clark County
bud.cave@clark.wa.gov

Mike Deason, Vice Chair

Public Works Director
City of Leavenworth
(509) 548-5275

Randy Hart, Chair

Grants Program Engineer
County Road Administration Board
(360) 664-3299

Liana Liu, P.E.

FHWA, Washington State Division
(360) 753-9553

Tom Rountree

Road Maintenance Supervisor
King County DOT/RSD
(206) 296-8196

Cheryl Clark

Group Leader, Development
Pacific NW Region, USFS
(503) 808-2409

Mike Sacco

Maintenance Trainer
WSDOT Eastern Region
(509) 324-6541

Jim Seitz

Transportation Specialist
Association of Washington Cities
(360) 753-4137

Richard A. Swan

Colville Tribal Business Council
Washington Tribal Governments
(509) 634-2214
1-888-881-7684 ext. 2214

Bruce Wagner

Road Operations Division Manager
Pierce County
(253) 798-6051

Dave Zabell

Director of Public Works
City of Bothell
(425) 486-2768

Jack Zeppenfeld

Street Division Supervisor
City of Moses Lake
(509) 766-9224

Associate Members

Joe Bonga

Road Construction/Maintenance
Bureau of Indian Affairs
(503) 231-6712

Kathy Lindquist

Research Implementation Manager
WSDOT Research Office
(360) 705-7976

Richard Rolland

Director
NW and Alaska TTAP
rolland@mail.ewu.edu
(509) 358-2225

WST2 Center

E-mail: WST2Center@wsdot.wa.gov

Home Page: <http://www.wsdot.wa.gov/TA/T2Center/T2hp.htm>



Washington State Technology Transfer Center
WSDOT - H&LP Division
P.O. Box 47390
Olympia, WA 98504-7390

PRSR STD
U.S.POSTAGE
PAID
Washington State
Department of Printing