

KEY

- ① METER BASE PER SERVING UTILITY REQUIREMENTS ~ SEE **STANDARD PLAN J-10.30**.
- ② MAIN BREAKER (SPST - SIZE PER BREAKER SCHEDULE)
- ③ PHOTOELECTRIC CONTROL BREAKER (SPST ~ 15 AMP ~ 120/240 VOLT)
- ④ TEST SWITCH (SPDT ~ SNAP ACTION ~ POSITIVE CLOSE ~ 15 AMP ~ 120/277 VOLT ~ "T" RATED)
- ⑤ PHOTOELECTRIC CONTROL UNIT ~ SEE **STANDARD SPECIFICATION 9-29.11(2)**
- ⑥ BRANCH BREAKER ~ SEE BREAKER SCHEDULE (SPST ~ 120/240 VOLT)
- ⑦ SPARE BRANCH BREAKER (SPST ~ 20 AMP ~ 120/240 VOLT)
- ⑧ CONTACTOR ~ SEE BREAKER SCHEDULE
- ⑨ ISOLATED NEUTRAL BUSS ~ 8 LUG COPPER
- ⑩ HINGED DEAD FRONT WITH 1/4 TURN FASTENERS OR SLIDE LATCHES ~ DEAD FRONT PANEL BOLTS SHALL NOT EXTEND INTO VERTICAL LIMITS OF THE BREAKER ARRAY(S)
- ⑪ CABINET MAIN BONDING JUMPER ASSEMBLY ~ BUSS SHALL BE 8 LUG TINNED COPPER ~ SEE **STANDARD PLAN J-10.20** FOR CABINET MAIN BONDING JUMPER ASSEMBLY DETAILS
- ⑫ METAL WIRING DIAGRAM HOLDER
- ⑬ 1/4" (IN) DIAMETER DRAIN HOLE ~ DRILL BEFORE GALVANIZING
- ⑭ MOUNTING HOLE ~ SEE **STANDARD PLAN J-10.12** CABINET BRACKET MOUNTING DETAIL
- ⑮ 4-CIRCUIT PANEL BOARD ~ MINIMUM SIZE WITH BACK-FED MAIN BREAKER
- ⑯ LABEL CABINET WITH BUSSWORK RATING
- ⑰ ARC FLASH AND SHOCK HAZARD LABEL ~ SEE DETAIL
- ⑱ CONNECTION TO GROUND ELECTRODE ~ SEE **STANDARD PLAN J-60.05**
- ⑲ 20 KA TYPE 1 OR TYPE 2 SURGE PROTECTION DEVICE ~ DIN RAIL MOUNT WITH PLUG-IN MODULE(S)
- ⑳ THREE POSITION DIN RAIL MOUNTED TERMINAL BLOCK ~ TERMINAL BLOCK SECTIONS SHALL BE BLACK, WHITE, AND RED AS SHOWN IN CABINET WIRING DIAGRAM

⚠ WARNING			
Arc Flash and Shock Hazard			
Appropriate PPE Required			
ARC FLASH PROTECTION		SHOCK PROTECTION	
Arc Flash Boundary (in)	00 In	Shock Hazard When Cover Removed	000 VAC
Incident Energy at 18 inches (cal/cm ²)	0.00	Limited Approach	00 In
Assessment Date:	00-00-0000	Restricted Approach	00 In
By:		Glove Class	00
WSDOT Approval Inspector:		Date:	

ARC FLASH AND SHOCK HAZARD LABEL DETAIL

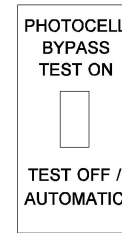

TEST SWITCH LABEL DETAIL

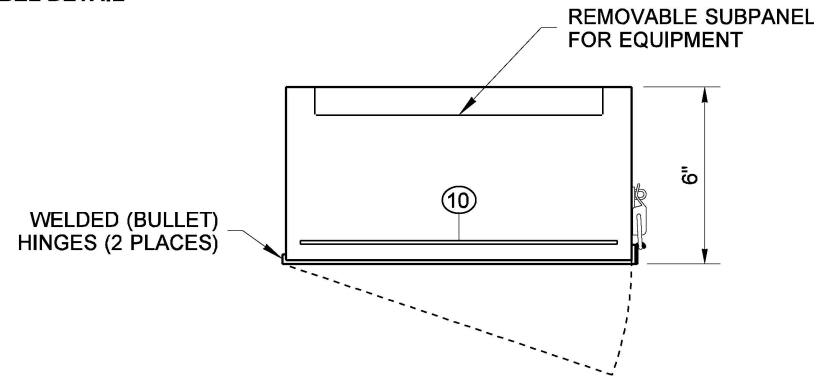

SECTION 1

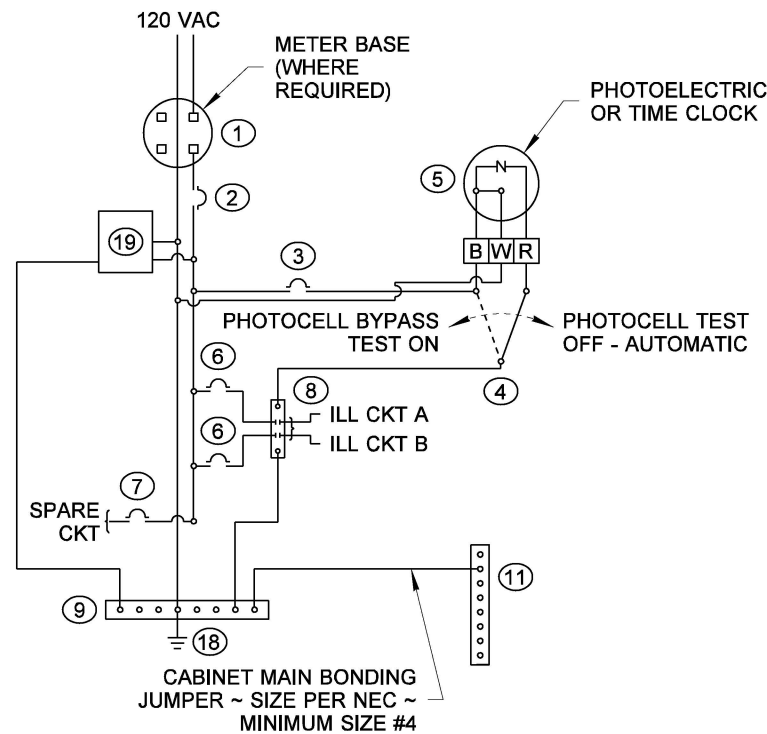

TYPE A WIRING DIAGRAM ~ 120 VOLT

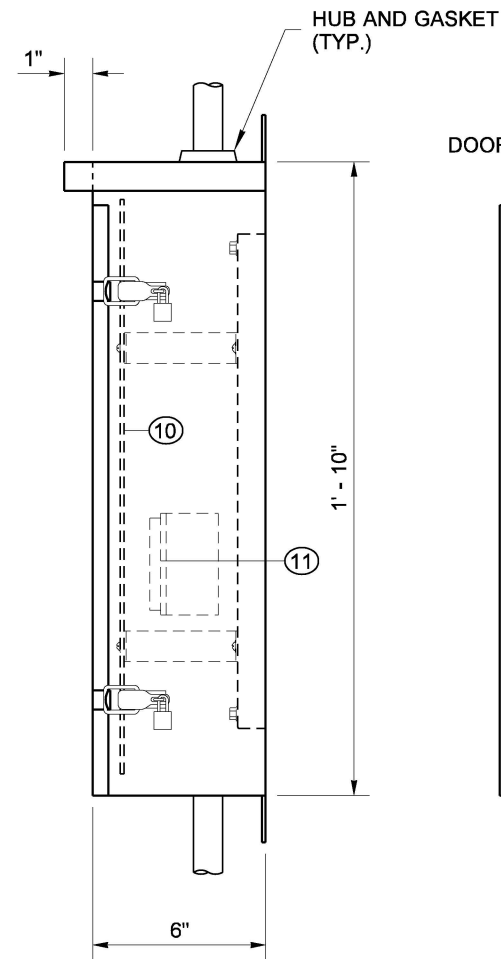

SIDE VIEW

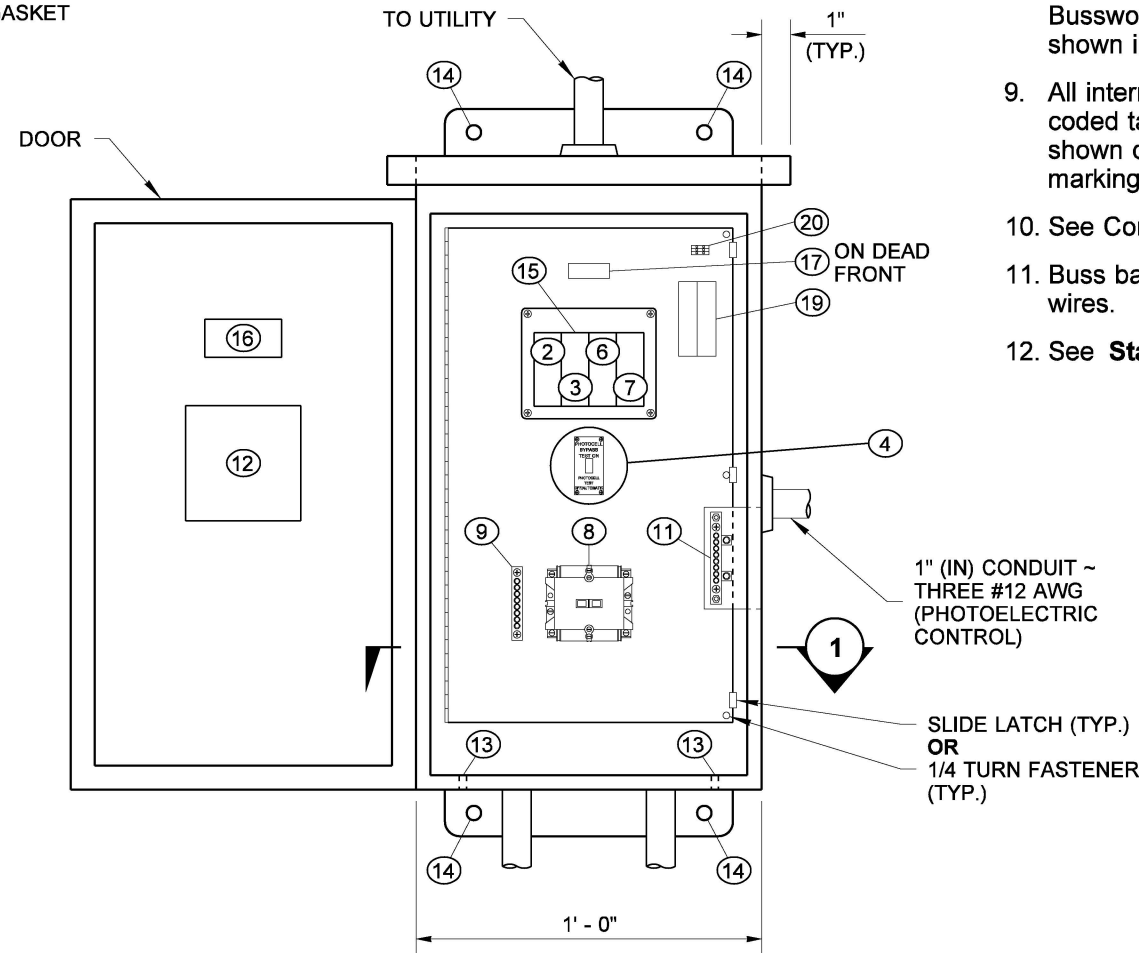

ELEVATION VIEW

TYPE A SERVICE CABINET

NOTES

- 1. See **Standard Specification Section 9-29.24** (Service Cabinets).
- 2. Cabinet shall be rated NEMA 3R.
- 3. Dimensions shown are minimum and shall be adjusted to accommodate the various sizes of equipment installed. A 1% tolerance is allowed for all dimensions.
- 4. Door shall be pad-lockable and gasketed.
- 5. Hinges shall have stainless steel or brass pins. See **Standard Plan J-10.20** for door hinge details.
- 6. When using two piece hinge type on galvanized enclosure, remove hinge pin prior to welding hinge to cabinet and prior to hot-dip galvanizing. After galvanizing, replace pin with brass pin and solder in place. See **Standard Plan J-10.20** for alternate door hinge details.
- 7. Equipment identified by Key Numbers 2, 3, 4, 6, 7, and 8 shall have an appropriately engraved phenolic name plate attached with screws or rivets. The name plate for Key Number 4 shall read as follows: "PHOTOCELL BYPASS TEST ON" AND "PHOTOCELL TEST OFF - AUTOMATIC." See Test Switch Label Detail.
- 8. All busswork shall be **ASTM B187** copper and shall have a minimum rating of 125 amps. All breakers shall bolt on to the busswork. Jumpering of breakers shall not be allowed. Busswork shall accommodate all future equipment as shown in the Breaker Schedule.
- 9. All internal wire runs shall be identified with "TO - FROM" coded tags labeled with the code letters and/or numbers shown on the Schedules. Approved PVC or polyolefin wire marking sleeves shall be used.
- 10. See Contract for Breaker and Contactor Schedule.
- 11. Buss bars shall be sized to accommodate up to #4 AWG wires.
- 12. See **Standard Plan J-10.14** for pole installation details.



Aug 18, 2021

**SERVICE CABINET TYPE A
(0 - 100 AMP TYPE 120 VOLT
SINGLE PHASE)
STANDARD PLAN J-10.16-02**

SHEET 1 OF 1 SHEET

APPROVED FOR PUBLICATION

Aug 18, 2021

STATE DESIGN ENGINEER



Washington State Department of Transportation

DRAWN BY: FERN LIDDELL