

DRAWN BY: BILL BERENS

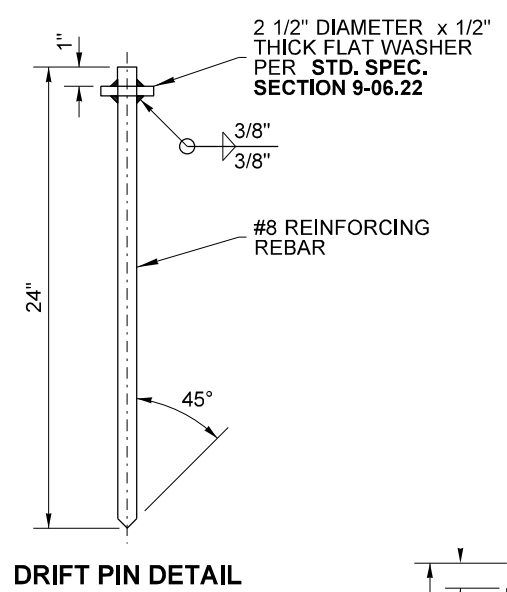

**NOTES**

- Concrete shall be Class 5000.
- Remove slack between barrier segments after inserting the connecting pin.
- Provide 2" minimum concrete cover over reinforcing steel, except for as noted on the plan.
- Connecting Pin head designs vary among different manufacturers. Pin designs that are shaped differently than those shown in the detail are acceptable, if the bearing surface is within the minimum and maximum widths specified.

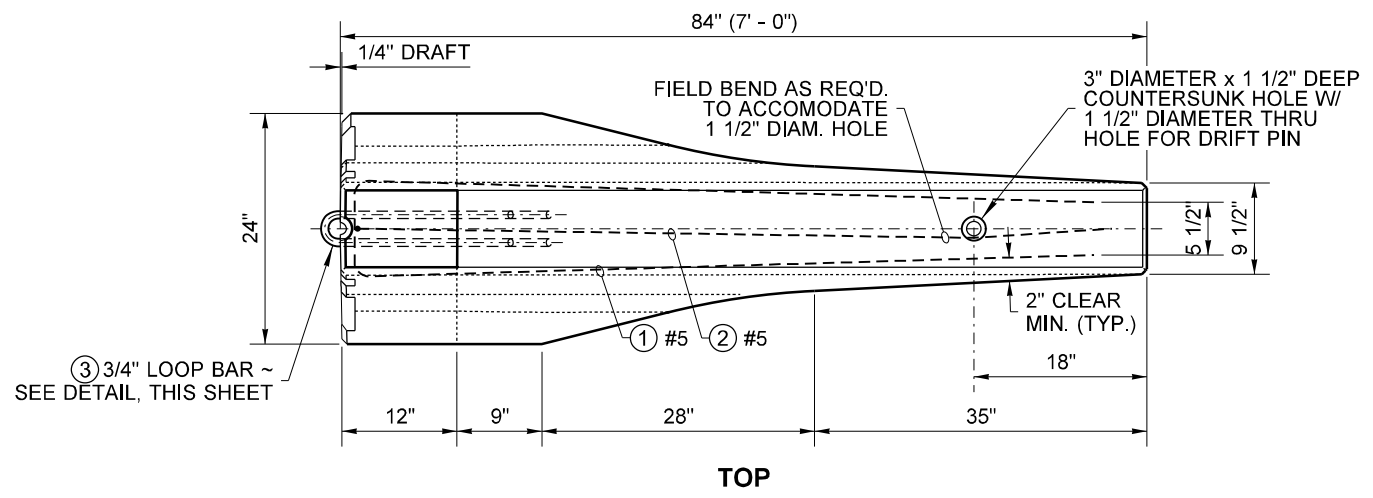
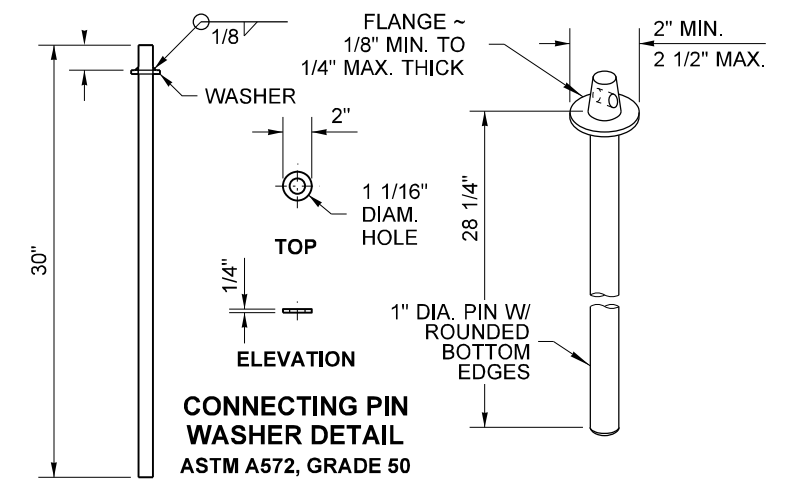
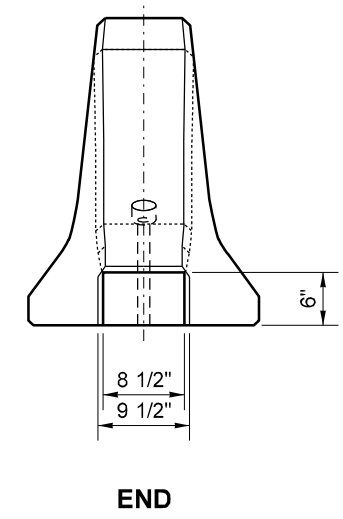
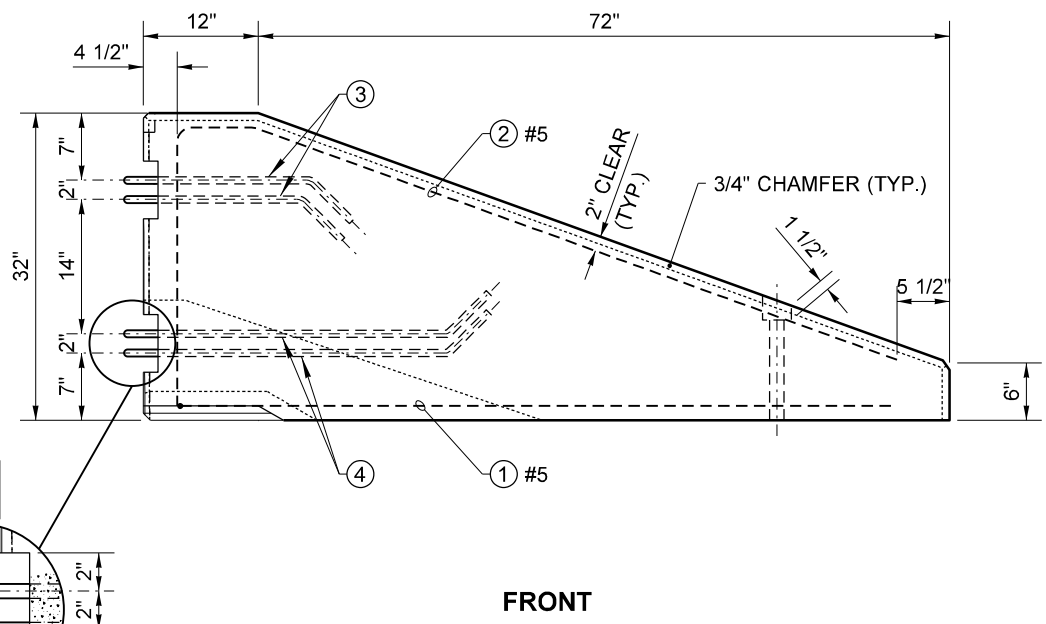
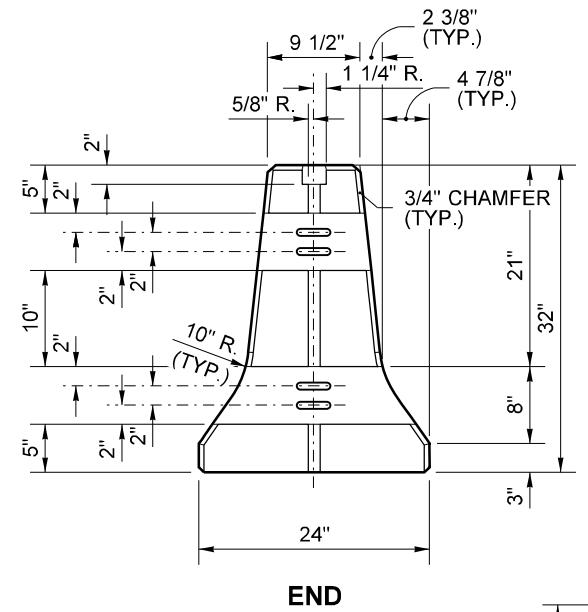

**CONNECTING PIN ASSEMBLY DETAIL**  
1" DIAMETER PER ASTM A449  
HOT DIP GALVANIZE AFTER FABRICATION PER ASTM F2329

WELDED WASHER PIN SEE NOTE 4

FORGED HEAD PIN (ALTERNATIVE)

**TYPICAL SLOT DETAIL**

**REINFORCING STEEL BENDING DIAGRAM**

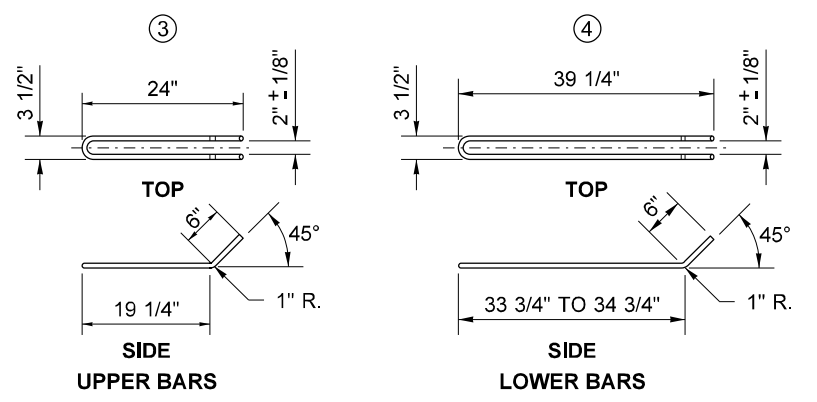
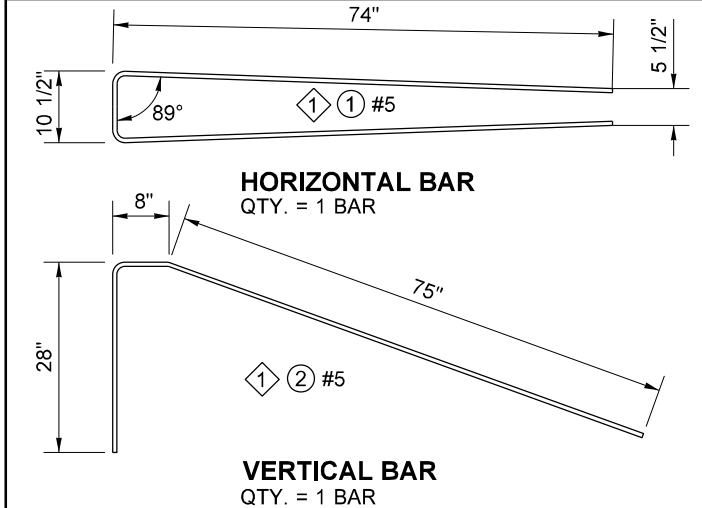

**NOTE:**  
STEEL WELDED WIRE REINFORCEMENT DEFORMED FOR CONCRETE MAY BE SUBSTITUTED FOR REINFORCING STEEL IN ACCORDANCE WITH STANDARD SPECIFICATION, SECTION 6-10.3

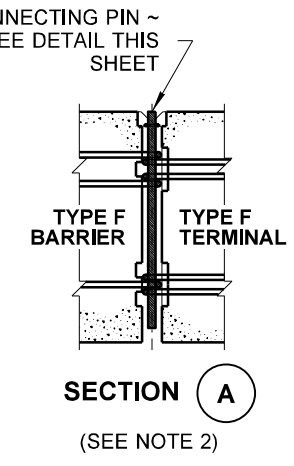
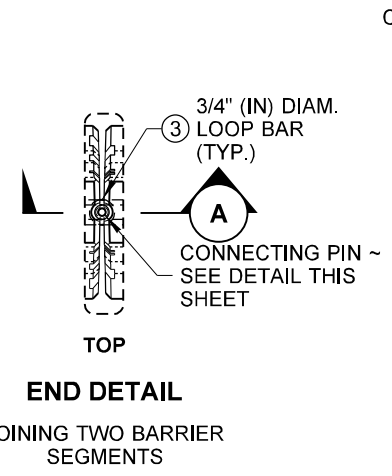

Sep 8, 2022

**CONCRETE BARRIER TYPE F (PRECAST) TERMINAL**  
**STANDARD PLAN C-60.80-01**

SHEET 1 OF 1 SHEET

APPROVED FOR PUBLICATION  
*Mark Gaines*  
Mark Gaines (Sep 8, 2022 09:53 PDT) Sep 8, 2022  
STATE DESIGN ENGINEER  
Washington State Department of Transportation